

STATE OF NORTH CAROLINA
DEPARTMENT OF TRANSPORTATION
RALEIGH, N.C.

PROPOSAL

INCLUDES ADDENDUM No. 1 DATED 04-11-2017

DATE AND TIME OF BID OPENING: **APRIL 18, 2017 AT 2:00 PM**

CONTRACT ID C203953
WBS 39079.3.4

FEDERAL-AID NO. STP-1302(069)
COUNTY BUNCOMBE
T.I.P. NO. U-4715B
MILES 80.000
ROUTE NO.
LOCATION ASHEVILLE - CITY WIDE SIGNAL IMPROVEMENTS.

TYPE OF WORK ITS.

NOTICE:

ALL BIDDERS SHALL COMPLY WITH ALL APPLICABLE LAWS REGULATING THE PRACTICE OF GENERAL CONTRACTING AS CONTAINED IN CHAPTER 87 OF THE GENERAL STATUTES OF NORTH CAROLINA WHICH REQUIRES THE BIDDER TO BE LICENSED BY THE N.C. LICENSING BOARD FOR CONTRACTORS WHEN BIDDING ON ANY NON-FEDERAL AID PROJECT WHERE THE BID IS \$30,000 OR MORE, EXCEPT FOR CERTAIN SPECIALTY WORK AS DETERMINED BY THE LICENSING BOARD. BIDDERS SHALL ALSO COMPLY WITH ALL OTHER APPLICABLE LAWS REGULATING THE PRACTICES OF ELECTRICAL, PLUMBING, HEATING AND AIR CONDITIONING AND REFRIGERATION CONTRACTING AS CONTAINED IN CHAPTER 87 OF THE GENERAL STATUTES OF NORTH CAROLINA. NOTWITHSTANDING THESE LIMITATIONS ON BIDDING, THE BIDDER WHO IS AWARDED ANY FEDERAL - AID FUNDED PROJECT SHALL COMPLY WITH CHAPTER 87 OF THE GENERAL STATUTES OF NORTH CAROLINA FOR LICENSING REQUIREMENTS WITHIN 60 CALENDAR DAYS OF BID OPENING.

BIDS WILL BE RECEIVED AS SHOWN BELOW:

THIS IS A SIGNAL PROPOSAL

5% BID BOND OR BID DEPOSIT REQUIRED

**PROPOSAL FOR THE CONSTRUCTION OF
CONTRACT No. C203953 IN BUNCOMBE COUNTY, NORTH CAROLINA**

Date _____ 20 _____

**DEPARTMENT OF TRANSPORTATION,
RALEIGH, NORTH CAROLINA**

The Bidder has carefully examined the location of the proposed work to be known as Contract No. C203953; has carefully examined the plans and specifications, which are acknowledged to be part of the proposal, the special provisions, the proposal, the form of contract, and the forms of contract payment bond and contract performance bond; and thoroughly understands the stipulations, requirements and provisions. The undersigned bidder agrees to be bound upon his execution of the bid and subsequent award to him by the Board of Transportation in accordance with this proposal to provide the necessary contract payment bond and contract performance bond within fourteen days after the written notice of award is received by him. The undersigned Bidder further agrees to provide all necessary machinery, tools, labor, and other means of construction; and to do all the work and to furnish all materials, except as otherwise noted, necessary to perform and complete the said contract in accordance with *the 2012 Standard Specifications for Roads and Structures* by the dates(s) specified in the Project Special Provisions and in accordance with the requirements of the Engineer, and at the unit or lump sum prices, as the case may be, for the various items given on the sheets contained herein.

The Bidder shall provide and furnish all the materials, machinery, implements, appliances and tools, and perform the work and required labor to construct and complete State Highway Contract No. C203953 in Buncombe County, for the unit or lump sum prices, as the case may be, bid by the Bidder in his bid and according to the proposal, plans, and specifications prepared by said Department, which proposal, plans, and specifications show the details covering this project, and hereby become a part of this contract.

The published volume entitled *North Carolina Department of Transportation, Raleigh, Standard Specifications for Roads and Structures, January 2012* with all amendments and supplements thereto, is by reference incorporated into and made a part of this contract; that, except as herein modified, all the construction and work included in this contract is to be done in accordance with the specifications contained in said volume, and amendments and supplements thereto, under the direction of the Engineer.

If the proposal is accepted and the award is made, the contract is valid only when signed either by the Contract Officer or such other person as may be designated by the Secretary to sign for the Department of Transportation. The conditions and provisions herein cannot be changed except over the signature of the said Contract Officer.

The quantities shown in the itemized proposal for the project are considered to be approximate only and are given as the basis for comparison of bids. The Department of Transportation may increase or decrease the quantity of any item or portion of the work as may be deemed necessary or expedient.

An increase or decrease in the quantity of an item will not be regarded as sufficient ground for an increase or decrease in the unit prices, nor in the time allowed for the completion of the work, except as provided for the contract.

Accompanying this bid is a bid bond secured by a corporate surety, or certified check payable to the order of the Department of Transportation, for five percent of the total bid price, which deposit is to be forfeited as liquidated damages in case this bid is accepted and the Bidder shall fail to provide the required payment and performance bonds with the Department of Transportation, under the condition of this proposal, within 14 calendar days after the written notice of award is received by him, as provided in the *Standard Specifications*; otherwise said deposit will be returned to the Bidder.



State Contract Officer

DocuSigned by:
Ronald Elton Davenport, Jr.
F81B6038A47A442...

4/11/2017

TABLE OF CONTENTS

**COVER SHEET
PROPOSAL SHEET**

PROJECT SPECIAL PROVISIONS

CONTRACT TIME AND LIQUIDATED DAMAGES: G-1
INTERMEDIATE CONTRACT TIME NUMBER 1 AND LIQUIDATED DAMAGES: G-1
INTERMEDIATE CONTRACT TIME NUMBER 2 AND LIQUIDATED DAMAGES: G-3
INTERMEDIATE CONTRACT TIME NUMBER 3 AND LIQUIDATED DAMAGES: G-4
INTERMEDIATE CONTRACT TIME NUMBER 4 AND LIQUIDATED DAMAGES: G-7
MAJOR CONTRACT ITEMS: G-7
SPECIALTY ITEMS: G-7
SCHEDULE OF ESTIMATED COMPLETION PROGRESS: G-8
DISADVANTAGED BUSINESS ENTERPRISE: G-8
CERTIFICATION FOR FEDERAL-AID CONTRACTS: G-21
CONTRACTOR'S LICENSE REQUIREMENTS: G-22
U.S. DEPARTMENT OF TRANSPORTATION HOTLINE: G-22
CARGO PREFERENCE ACT: G-23
SUBSURFACE INFORMATION: G-23
LOCATING EXISTING UNDERGROUND UTILITIES: G-23
VALUE ENGINEERING PROPOSAL: G-23
RESOURCE CONSERVATION AND ENV. SUSTAINABLE PRACTICES: G-25
DOMESTIC STEEL: G-25
IRAN DIVESTMENT ACT: G-26
GIFTS FROM VENDORS AND CONTRACTORS: G-26
LIABILITY INSURANCE: G-27
EMPLOYMENT: G-27
STATE HIGHWAY ADMINISTRATOR TITLE CHANGE: G-27
SUBLETTING OF CONTRACT: G-27

ROADWAY R-1

STANDARD SPECIAL PROVISIONS

AVAILABILITY FUNDS – TERMINATION OF CONTRACTS SSP-1
ERRATA SSP-2
PLANT AND PEST QUARANTINES SSP-4
AWARD OF CONTRACT SSP-5
MINORITY AND FEMALE EMPLOYMENT REQUIREMENTS SSP-10
REQUIRED CONTRACT PROVISIONS FEDERAL-AID CONST. CONTRACTS SSP-13
ON-THE-JOB TRAINING SSP-22
NCDENR NAME CHANGE SSP-25
MINIMUM WAGES SSP-26

UNIT PROJECT SPECIAL PROVISIONS

ITS.....ITS-1

PROPOSAL ITEM SHEET

ITEM SHEET(S) (TAN SHEETS)

PROJECT SPECIAL PROVISIONS**GENERAL****CONTRACT TIME AND LIQUIDATED DAMAGES:**

(7-1-95) (Rev. 12-18-07)

108

SP1 G10 B

The date of availability for this contract is **May 31, 2017**.

The completion date for this contract is **December 22, 2020**.

The liquidated damages for this contract are **One Thousand Five Hundred Dollars (\$ 1,500.00)** per calendar day.

INTERMEDIATE CONTRACT TIME NUMBER 1 AND LIQUIDATED DAMAGES:

(2-20-07)

108

SP1 G14 A

The Contractor shall complete the required work of installing, maintaining, and removing the traffic control devices for lane closures and restoring traffic to the existing traffic pattern. The Contractor shall not close or narrow a lane of traffic on **I-26, I-40, I-240, Ramps and Loops, US-25 (Hendersonville Road), US-25A Sweeten Road (Rock Hill Road to US-25 Hendersonville Road), US-19/23/74A (Patton Avenue/Smokey Park Highway), South Tunnel Road and Tunnel Road (Old Chunn's Cove Road to NC-81 (Swannanoa River Road))** during the following time restrictions:

DAY AND TIME RESTRICTIONS

**6:00 A.M. to 7:00 P.M.
Monday thru Sunday**

In addition, the Contractor shall not close or narrow a lane of traffic on **I-26, I-40, I-240, Ramps and Loops, US-25 (Hendersonville Road), US-25A Sweeten Road (Rock Hill Road to US-25 Hendersonville Road), US-19/23/74A (Patton Avenue/Smokey Park Highway), South Tunnel Road and Tunnel Road (Old Chunn's Cove Road to NC-81 (Swannanoa River Road))**, detain and/or alter the traffic flow on or during holidays, holiday weekends, special events, or any other time when traffic is unusually heavy, including the following schedules:

HOLIDAY AND HOLIDAY WEEKEND LANE CLOSURE RESTRICTIONS

1. For **unexpected occurrence** that creates unusually high traffic volumes, as directed by the Engineer.
2. For **New Year's Day**, between the hours of **6:00 A.M.** December 31st and **7:00 P.M.** January 2nd. If New Year's Day is on a Friday, Saturday, Sunday or Monday, then until **7:00 P.M.** the following Tuesday.
3. For **Easter**, between the hours of **6:00 A.M.** Thursday and **7:00 P.M.** Monday.

4. For **Memorial Day**, between the hours of **6:00 A.M.** Friday and **7:00 P.M.** Tuesday.
5. For **Independence Day**, between the hours of **6:00 A.M.** the day before Independence Day and **7:00 P.M.** the day after Independence Day.

If **Independence Day** is on a Friday, Saturday, Sunday or Monday, then between the hours of **6:00 A.M.** the Thursday before Independence Day and **7:00 P.M.** the Tuesday after Independence Day.
6. For **Labor Day**, between the hours of **6:00 A.M.** Friday and **7:00 P.M.** Tuesday.
7. For **Thanksgiving Day**, between the hours of **6:00 A.M.** Tuesday and **7:00 P.M.** Monday.
8. For **Christmas**, between the hours of **6:00 A.M.** the Friday before the week of Christmas Day and **7:00 P.M.** the following Tuesday after the week of Christmas Day.
9. For **Biltmore's Annual Concert Series**, occurring at **Biltmore Estates** between **four (4)** hours before the start and **two (2)** hours after the end of **each concert in Biltmore's Annual Concert Series**.
10. For **weekends during the holiday shopping period at the Asheville Mall between the weekend of Thanksgiving and the weekend of Christmas**, between the hours of **9:00 A.M.** and **9:00 P.M.** on both Saturday and Sunday. (This note only applies to Tunnel Road, South Tunnel Road and Wood Avenue).

Holidays and holiday weekends shall include New Year's Day, Easter, Memorial Day, Independence Day, Labor Day, Thanksgiving, and Christmas. The Contractor shall schedule his work so that lane closures will not be required during these periods, unless otherwise directed by the Engineer.

The time of availability for this intermediate contract work shall be the time the Contractor begins to install all traffic control devices for lane closures according to the time restrictions listed herein.

The completion time for this intermediate contract work shall be the time the Contractor is required to complete the removal of all traffic control devices for lane closures according to the time restrictions stated above and place traffic in the existing traffic pattern.

The liquidated damages are **One Thousand Dollars (\$ 1,000.00)** per hour.

INTERMEDIATE CONTRACT TIME NUMBER 2 AND LIQUIDATED DAMAGES:

(2-20-07)

108

SP1 G14 A

The Contractor shall complete the required work of installing, maintaining, and removing the traffic control devices for lane closures and restoring traffic to the existing traffic pattern. The Contractor shall not close or narrow a lane of traffic on **Tunnel Road (College Street to Old Chunn's Cove Road)** during the following time restrictions:

DAY AND TIME RESTRICTIONS

**6:00 A.M. to 10:00 P.M.
Monday thru Sunday**

In addition, the Contractor shall not close or narrow a lane of traffic on **Tunnel Road (College Street to Old Chunn's Cove Road)**, detain and/or alter the traffic flow on or during holidays, holiday weekends, special events, or any other time when traffic is unusually heavy, including the following schedules:

HOLIDAY AND HOLIDAY WEEKEND LANE CLOSURE RESTRICTIONS

1. For **unexpected occurrence** that creates unusually high traffic volumes, as directed by the Engineer.
2. For **New Year's Day**, between the hours of **6:00 A.M.** December 31st and **10:00 P.M.** January 2nd. If New Year's Day is on a Friday, Saturday, Sunday or Monday, then until **10:00 P.M.** the following Tuesday.
3. For **Easter**, between the hours of **6:00 A.M.** Thursday and **10:00 P.M.** Monday.
4. For **Memorial Day**, between the hours of **6:00 A.M.** Friday and **10:00 P.M.** Tuesday.
5. For **Independence Day**, between the hours of **6:00 A.M.** the day before Independence Day and **10:00 P.M.** the day after Independence Day.

If **Independence Day** is on a Friday, Saturday, Sunday or Monday, then between the hours of **6:00 A.M.** the Thursday before Independence Day and **10:00 P.M.** the Tuesday after Independence Day.
6. For **Labor Day**, between the hours of **6:00 A.M.** Friday and **10:00 P.M.** Tuesday.
7. For **Thanksgiving Day**, between the hours of **6:00 A.M.** Tuesday and **10:00 P.M.** Monday.
8. For **Christmas**, between the hours of **6:00 A.M.** the Friday before the week of Christmas Day and **10:00 P.M.** the following Tuesday after the week of Christmas Day.

Holidays and holiday weekends shall include New Year's Day, Easter, Memorial Day, Independence Day, Labor Day, Thanksgiving, and Christmas. The Contractor shall schedule his work so that lane closures will not be required during these periods, unless otherwise directed by the Engineer.

The time of availability for this intermediate contract work shall be the time the Contractor begins to install all traffic control devices for lane closures according to the time restrictions listed herein.

The completion time for this intermediate contract work shall be the time the Contractor is required to complete the removal of all traffic control devices for lane closures according to the time restrictions stated above and place traffic in the existing traffic pattern.

The liquidated damages are **Five Hundred Dollars (\$ 500.00)** per fifteen (15) minute time period.

INTERMEDIATE CONTRACT TIME NUMBER 3 AND LIQUIDATED DAMAGES:

(2-20-07)

108

SP1 G14 A

The Contractor shall complete the required work of installing, maintaining, and removing the traffic control devices for lane closures and restoring traffic to the existing traffic pattern. The Contractor shall not close or narrow a lane of traffic on **any road other than I-26, I-40, I-240, US-25 (Hendersonville Road), US-25A Sweeten Road (Rock Hill Road to US-25 Hendersonville Road), US-19/23/74A (Patton Avenue/Smokey Park Highway), South Tunnel Road and Tunnel Road (College Street to NC-81 (Swannanoa River Road))** during the following time restrictions:

DAY AND TIME RESTRICTIONS

**6:00 A.M. to 9:00 A.M.
& 4:00 P.M. to 7:00 P.M.
Monday thru Sunday**

In addition, the Contractor shall not close or narrow a lane of traffic on **any road other than I-26, I-40, I-240, US-25 (Hendersonville Road), US-25A Sweeten Road (Rock Hill Road to US-25 Hendersonville Road), US-19/23/74A (Patton Avenue/Smokey Park Highway), South Tunnel Road and Tunnel Road (College Street to NC-81 (Swannanoa River Road))**, detain and/or alter the traffic flow on or during holidays, holiday weekends, special events, or any other time when traffic is unusually heavy, including the following schedules:

HOLIDAY AND HOLIDAY WEEKEND LANE CLOSURE RESTRICTIONS

1. For **unexpected occurrence** that creates unusually high traffic volumes, as directed by the Engineer.
2. For **New Year's Day**, between the hours of **6:00 A.M.** December 31st and **7:00 P.M.** January 2nd. If New Year's Day is on a Friday, Saturday, Sunday or Monday, then until **7:00 P.M.** the following Tuesday.

3. For **Easter**, between the hours of **6:00 A.M.** Thursday and **7:00 P.M.** Monday.
4. For **Memorial Day**, between the hours of **6:00 A.M.** Friday and **7:00 P.M.** Tuesday.
5. For **Independence Day**, between the hours of **6:00 A.M.** the day before Independence Day and **7:00 P.M.** the day after Independence Day.

If **Independence Day** is on a Friday, Saturday, Sunday or Monday, then between the hours of **6:00 A.M.** the Thursday before Independence Day and **7:00 P.M.** the Tuesday after Independence Day.

6. For **Labor Day**, between the hours of **6:00 A.M.** Friday and **7:00 P.M.** Tuesday.
7. For **Thanksgiving Day**, between the hours of **6:00 A.M.** Tuesday and **7:00 P.M.** Monday.
8. For **Christmas**, between the hours of **6:00 A.M.** the Friday before the week of Christmas Day and **7:00 P.M.** the following Tuesday after the week of Christmas Day.
9. For the weekend of the **Annual Asheville Marathon and Half Marathon** in March, do not perform any work in Biltmore Village between the hours of **7:00 A.M.** Friday through **9:00 A.M.** the Monday after the **Annual Asheville Marathon and Half Marathon** without the prior approval of the Engineer. Call (828) 259-5943 or visit the Marathon and Half Marathon's website at www.ashevillamarathon.com to confirm the dates of the Annual Marathon and Half Marathon.
10. For **Asheville Tourist home games**, occurring at **McCormick Field**, between **four (4)** hours before the start and **four (4)** hours after the end of each of the **Asheville Tourist home game**. (This note only applies to Charlotte Street, McCormick Place and Biltmore Avenue).
11. For the **Mountain State Fair**, occurring at the **WNC Agricultural Center in Fletcher** between the hours of **7:00 A.M.** the day before the start and **6:00 P.M.** the day after the end of the **Mountain State Fair**. This note only applies to NC-280 (Airport Road) South of I-26.
12. Do not close or narrow travel lanes or close sidewalks or pedestrian crossings within the U.S. Cellular Center area without prior approval of the Engineer. Submit to the Engineer for review and approval two weeks in advance a schedule for proposed work that will require narrowing or closing a lane, road, sidewalk or pedestrian crossing. The U.S. Cellular Center area is defined as the area bounded by Haywood Street, Hiwassee Street, Rankin Avenue and Walnut Street.
13. Do not close or narrow travel lanes or close sidewalks or pedestrian crossing within ½ mile of a school during arrival and dismissal hours on a school day. Coordinate with the affected school concerning operational hours and school days. As a minimum, do not close or

narrow a lane or close a sidewalk or pedestrian crossing during hours posed on school speed zone signs (when present).

14. For **UNC Asheville basketball games**, occurring at U.S. Cellular Center between **two (2)** hours before the start and **two (2)** hours after the end of the **UNC Asheville basketball games**.
15. For **weekends during the holiday shopping period at the Asheville Outlets between the weekend of Thanksgiving and the weekend of Christmas**, between the hours of **9:00 A.M.** and **9:00 P.M.** on both Saturday and Sunday. (This note only applies to NC 191(Brevard Road from I-26 to Morris Road/Overland Industrial Park Boulevard)).
16. Do not close or narrow travel lanes or close sidewalks or pedestrian crossings within UNC Asheville (UNC-A) Main Campus area without prior approval of the Engineer. Submit to the Engineer for review and approval two weeks in advance a schedule for proposed work that will require narrowing or closing a lane, road, sidewalk or pedestrian crossing. The UNC-A Main Campus area is defined as the area bounded by Broadway, Merrimon Avenue, W.T. Weaver Boulevard, and I-26.
17. Do not close or narrow travel lanes or close sidewalks or pedestrian crossing for Asheville-Buncombe Technical Community College campus on Victoria Road between Lily Carmichael Drive and Fernihurst Drive without prior approval of the Engineer. Submit to the Engineer for review and approval two weeks in advance a schedule for proposed work that will require narrowing or closing a lane, road, or sidewalk or pedestrian crossing.

Holidays and holiday weekends shall include New Year's Day, Easter, Memorial Day, Independence Day, Labor Day, Thanksgiving, and Christmas. The Contractor shall schedule his work so that lane closures will not be required during these periods, unless otherwise directed by the Engineer.

The time of availability for this intermediate contract work shall be the time the Contractor begins to install all traffic control devices for lane closures according to the time restrictions listed herein.

The completion time for this intermediate contract work shall be the time the Contractor is required to complete the removal of all traffic control devices for lane closures according to the time restrictions stated above and place traffic in the existing traffic pattern.

The liquidated damages are **One Thousand Dollars (\$ 1,000.00)** per hour.

INTERMEDIATE CONTRACT TIME NUMBER 4 AND LIQUIDATED DAMAGES:

(2-20-07) (Rev. 10-15-13)

108

SP1 G14 E

The Contractor shall complete the required work of installing, maintaining and removing the traffic control devices for road closures and restoring traffic to the existing traffic pattern. The Contractor shall not close **Any Road** during the following time restrictions:

DAY AND TIME RESTRICTIONS

Monday thru Sunday from 6:00 A.M. to 9:00 P.M.

The maximum allowable time for installing cable across road is **twenty (20)** minutes for **Any Road**. The Contractor shall reopen the travel lanes to traffic until any resulting traffic queue is depleted.

The time of availability for this intermediate contract time will be the time the Contractor begins to install traffic control devices required for the road closures according to the time restrictions stated herein.

The completion time for this intermediate contract time will be the time the Contractor is required to complete the removal of traffic control devices required for the road closures according to the time restrictions stated herein and restore traffic to the existing traffic pattern.

The liquidated damages are **One Thousand Dollars (\$1,000.00)** per twenty (20) minute time period.

MAJOR CONTRACT ITEMS:

(2-19-02)

104

SP1 G28

The following listed items are the major contract items for this contract (see Article 104-5 of the *2012 Standard Specifications*):

| Line # | Description |
|---------------|---|
| 76 — | Controller With Cabinet & Aux File (2070E, 332, Base Mounted) |

SPECIALTY ITEMS:

(7-1-95)(Rev. 1-17-12)

108-6

SP1 G37

Items listed below will be the specialty items for this contract (see Article 108-6 of the *2012 Standard Specifications*).

| Line # | Description |
|---------------|-----------------------------|
| 14-15 | Long-Life Pavement Markings |

SCHEDULE OF ESTIMATED COMPLETION PROGRESS:

(7-15-08) (Rev. 5-17-16)

108-2

SP1 G58

The Contractor's attention is directed to the Standard Special Provision entitled *Availability of Funds Termination of Contracts* included elsewhere in this proposal. The Department of Transportation's schedule of estimated completion progress for this project as required by that Standard Special Provision is as follows:

| | <u>Fiscal Year</u> | <u>Progress (% of Dollar Value)</u> |
|------|---------------------------|--|
| 2017 | (7/01/16 - 6/30/17) | 2% of Total Amount Bid |
| 2018 | (7/01/17 - 6/30/18) | 40% of Total Amount Bid |
| 2019 | (7/01/18 - 6/30/19) | 30% of Total Amount Bid |
| 2020 | (7/01/19 - 6/30/20) | 21% of Total Amount Bid |
| 2021 | (7/-1/20 – 6/30/21) | 7% of Total Amount Bid |

The Contractor shall also furnish his own progress schedule in accordance with Article 108-2 of the *2012 Standard Specifications*. Any acceleration of the progress as shown by the Contractor's progress schedule over the progress as shown above shall be subject to the approval of the Engineer.

DISADVANTAGED BUSINESS ENTERPRISE:

(10-16-07)(Rev. 1-17-17)

102-15(J)

SP1 G61

Description

The purpose of this Special Provision is to carry out the U.S. Department of Transportation's policy of ensuring nondiscrimination in the award and administration of contracts financed in whole or in part with Federal funds. This provision is guided by 49 CFR Part 26.

Definitions

Additional DBE Subcontractors - Any DBE submitted at the time of bid that will not be used to meet the DBE goal. No submittal of a Letter of Intent is required.

Committed DBE Subcontractor - Any DBE submitted at the time of bid that is being used to meet the DBE goal by submission of a Letter of Intent. Or any DBE used as a replacement for a previously committed DBE firm.

Contract Goal Requirement - The approved DBE participation at time of award, but not greater than the advertised contract goal.

DBE Goal - A portion of the total contract, expressed as a percentage, that is to be performed by committed DBE subcontractor(s).

Disadvantaged Business Enterprise (DBE) - A firm certified as a Disadvantaged Business Enterprise through the North Carolina Unified Certification Program.

Goal Confirmation Letter - Written documentation from the Department to the bidder confirming the Contractor's approved, committed DBE participation along with a listing of the committed DBE firms.

Manufacturer - A firm that operates or maintains a factory or establishment that produces on the premises, the materials or supplies obtained by the Contractor.

Regular Dealer - A firm that owns, operates, or maintains a store, warehouse, or other establishment in which the materials or supplies required for the performance of the contract are bought, kept in stock, and regularly sold to the public in the usual course of business. A regular dealer engages in, as its principal business and in its own name, the purchase and sale or lease of the products in question. A regular dealer in such bulk items as steel, cement, gravel, stone, and petroleum products need not keep such products in stock, if it owns and operates distribution equipment for the products. Brokers and packagers are not regarded as manufacturers or regular dealers within the meaning of this section.

North Carolina Unified Certification Program (NCUCP) - A program that provides comprehensive services and information to applicants for DBE certification, such that an applicant is required to apply only once for a DBE certification that will be honored by all recipients of USDOT funds in the state and not limited to the Department of Transportation only. The Certification Program is in accordance with 49 CFR Part 26.

United States Department of Transportation (USDOT) - Federal agency responsible for issuing regulations (49 CFR Part 26) and official guidance for the DBE program.

Forms and Websites Referenced in this Provision

DBE Payment Tracking System - On-line system in which the Contractor enters the payments made to DBE subcontractors who have performed work on the project.
<https://apps.dot.state.nc.us/Vendor/PaymentTracking/>

DBE-IS Subcontractor Payment Information - Form for reporting the payments made to all DBE firms working on the project. This form is for paper bid projects only.
<https://connect.ncdot.gov/business/Turnpike/Documents/Form%20DBE-IS%20Subcontractor%20Payment%20Information.pdf>

RF-1 DBE Replacement Request Form - Form for replacing a committed DBE.
<http://connect.ncdot.gov/projects/construction/Construction%20Forms/DBE%20MBE%20WBE%20Replacement%20Request%20Form.pdf>

SAF Subcontract Approval Form - Form required for approval to sublet the contract.
<http://connect.ncdot.gov/projects/construction/Construction%20Forms/Subcontract%20Approval%20Form%20Rev.%202012.zip>

JC-1 Joint Check Notification Form - Form and procedures for joint check notification. The form acts as a written joint check agreement among the parties providing full and prompt disclosure of the expected use of joint checks.

<http://connect.ncdot.gov/projects/construction/Construction%20Forms/Joint%20Check%20Notification%20Form.pdf>

Letter of Intent - Form signed by the Contractor and the DBE subcontractor, manufacturer or regular dealer that affirms that a portion of said contract is going to be performed by the signed DBE for the amount listed at the time of bid.

<http://connect.ncdot.gov/letting/LetCentral/Letter%20of%20Intent%20to%20Perform%20as%20a%20Subcontractor.pdf>

Listing of DBE Subcontractors Form - Form for entering DBE subcontractors on a project that will meet this DBE goal. This form is for paper bids only.

[http://connect.ncdot.gov/municipalities/Bid%20Proposals%20for%20LGA%20Content/08%20DBE%20Subcontractors%20\(Federal\).docx](http://connect.ncdot.gov/municipalities/Bid%20Proposals%20for%20LGA%20Content/08%20DBE%20Subcontractors%20(Federal).docx)

Subcontractor Quote Comparison Sheet - Spreadsheet for showing all subcontractor quotes in the work areas where DBEs quoted on the project. This sheet is submitted with good faith effort packages.

<http://connect.ncdot.gov/business/SmallBusiness/Documents/DBE%20Subcontractor%20Quote%20Comparison%20Example.xls>

DBE Goal

The following DBE goal for participation by Disadvantaged Business Enterprises is established for this contract:

Disadvantaged Business Enterprises **1.0** %

- (A) *If the DBE goal is more than zero*, the Contractor shall exercise all necessary and reasonable steps to ensure that DBEs participate in at least the percent of the contract as set forth above as the DBE goal.
- (B) *If the DBE goal is zero*, the Contractor shall make an effort to recruit and use DBEs during the performance of the contract. Any DBE participation obtained shall be reported to the Department.

Directory of Transportation Firms (Directory)

Real-time information is available about firms doing business with the Department and firms that are certified through NCUCP in the Directory of Transportation Firms. Only firms identified in the Directory as DBE certified shall be used to meet the DBE goal. The Directory can be found at the following link. [https:// www.ebs.nc.gov/VendorDirectory/default.html](https://www.ebs.nc.gov/VendorDirectory/default.html)

The listing of an individual firm in the directory shall not be construed as an endorsement of the firm's capability to perform certain work.

Listing of DBE Subcontractors

At the time of bid, bidders shall submit all DBE participation that they anticipate to use during the life of the contract. Only those identified to meet the DBE goal will be considered committed, even though the listing shall include both committed DBE subcontractors and additional DBE subcontractors. Additional DBE subcontractor participation submitted at the time of bid will be used toward the Department's overall race-neutral goal. Only those firms with current DBE certification at the time of bid opening will be acceptable for listing in the bidder's submittal of DBE participation. The Contractor shall indicate the following required information:

(A) Electronic Bids

Bidders shall submit a listing of DBE participation in the appropriate section of Expedite, the bidding software of Bid Express[®].

- (1) Submit the names and addresses of DBE firms identified to participate in the contract. If the bidder uses the updated listing of DBE firms shown in Expedite, the bidder may use the dropdown menu to access the name and address of the DBE firm.
- (2) Submit the contract line numbers of work to be performed by each DBE firm. When no figures or firms are entered, the bidder will be considered to have no DBE participation.
- (3) The bidder shall be responsible for ensuring that the DBE is certified at the time of bid by checking the Directory of Transportation Firms. If the firm is not certified at the time of the bid-letting, that DBE's participation will not count towards achieving the DBE goal.

(B) Paper Bids

- (1) *If the DBE goal is more than zero,*
 - (a) Bidders, at the time the bid proposal is submitted, shall submit a listing of DBE participation, including the names and addresses on *Listing of DBE Subcontractors* contained elsewhere in the contract documents in order for the bid to be considered responsive. Bidders shall indicate the total dollar value of the DBE participation for the contract.
 - (b) If bidders have no DBE participation, they shall indicate this on the *Listing of DBE Subcontractors* by entering the word "None" or the number "0." This form shall be completed in its entirety. **Blank forms will not be deemed to represent zero participation.** Bids submitted that do not have

DBE participation indicated on the appropriate form will not be read publicly during the opening of bids. The Department will not consider these bids for award and the proposal will be rejected.

- (c) The bidder shall be responsible for ensuring that the DBE is certified at the time of bid by checking the Directory of Transportation Firms. If the firm is not certified at the time of the bid-letting, that DBE's participation will not count towards achieving the corresponding goal.
- (2) *If the DBE goal is zero*, entries on the *Listing of DBE Subcontractors* are not required for the zero goal, however any DBE participation that is achieved during the project shall be reported in accordance with requirements contained elsewhere in the special provision.

DBE Prime Contractor

When a certified DBE firm bids on a contract that contains a DBE goal, the DBE firm is responsible for meeting the goal or making good faith efforts to meet the goal, just like any other bidder. In most cases, a DBE bidder on a contract will meet the DBE goal by virtue of the work it performs on the contract with its own forces. However, all the work that is performed by the DBE bidder and any other DBE subcontractors will count toward the DBE goal. The DBE bidder shall list itself along with any DBE subcontractors, if any, in order to receive credit toward the DBE goal.

For example, if the DBE goal is 45% and the DBE bidder will only perform 40% of the contract work, the prime will list itself at 40%, and the additional 5% shall be obtained through additional DBE participation with DBE subcontractors or documented through a good faith effort.

DBE prime contractors shall also follow Sections A and B listed under *Listing of DBE Subcontractor* just as a non-DBE bidder would.

Written Documentation – Letter of Intent

The bidder shall submit written documentation for each DBE that will be used to meet the DBE goal of the contract, indicating the bidder's commitment to use the DBE in the contract. This documentation shall be submitted on the Department's form titled *Letter of Intent*.

The documentation shall be received in the office of the State Contractor Utilization Engineer or at DBE@ncdot.gov no later than 10:00 a.m. of the sixth calendar day following opening of bids, unless the sixth day falls on an official state holiday. In that situation, it is due in the office of the State Contractor Utilization Engineer no later than 10:00 a.m. on the next official state business day.

If the bidder fails to submit the Letter of Intent from each committed DBE to be used toward the DBE goal, or if the form is incomplete (i.e. both signatures are not present), the DBE participation will not count toward meeting the DBE goal. If the lack of this participation drops the commitment

below the DBE goal, the Contractor shall submit evidence of good faith efforts, completed in its entirety, to the State Contractor Utilization Engineer or DBE@ncdot.gov no later than 10:00 a.m. on the eighth calendar day following opening of bids, unless the eighth day falls on an official state holiday. In that situation, it is due in the office of the State Contractor Utilization Engineer no later than 10:00 a.m. on the next official state business day.

Submission of Good Faith Effort

If the bidder fails to meet or exceed the DBE goal, the apparent lowest responsive bidder shall submit to the Department documentation of adequate good faith efforts made to reach the DBE goal.

A hard copy and an electronic copy of this information shall be received in the office of the State Contractor Utilization Engineer or at DBE@ncdot.gov no later than 10:00 a.m. on the sixth calendar day following opening of bids unless the sixth day falls on an official state holiday. In that situation, it is due in the office of the State Contractor Utilization Engineer no later than 10:00 a.m. on the next official state business day. If the contractor cannot send the information electronically, then one complete set and 9 copies of this information shall be received under the same time constraints above.

Note: Where the information submitted includes repetitious solicitation letters, it will be acceptable to submit a representative letter along with a distribution list of the firms that were solicited. Documentation of DBE quotations shall be a part of the good faith effort submittal. This documentation may include written subcontractor quotations, telephone log notations of verbal quotations, or other types of quotation documentation.

Consideration of Good Faith Effort for Projects with DBE Goals More Than Zero

Adequate good faith efforts mean that the bidder took all necessary and reasonable steps to achieve the goal which, by their scope, intensity, and appropriateness, could reasonably be expected to obtain sufficient DBE participation. Adequate good faith efforts also mean that the bidder actively and aggressively sought DBE participation. Mere *pro forma* efforts are not considered good faith efforts.

The Department will consider the quality, quantity, and intensity of the different kinds of efforts a bidder has made. Listed below are examples of the types of actions a bidder will take in making a good faith effort to meet the goal and are not intended to be exclusive or exhaustive, nor is it intended to be a mandatory checklist.

- (A) Soliciting through all reasonable and available means (e.g. attendance at pre-bid meetings, advertising, written notices, use of verifiable electronic means through the use of the NCDOT Directory of Transportation Firms) the interest of all certified DBEs who have the capability to perform the work of the contract. The bidder must solicit this interest within at least 10 days prior to bid opening to allow the DBEs to respond to the solicitation. Solicitation shall provide the opportunity to DBEs within the Division and surrounding

Divisions where the project is located. The bidder must determine with certainty if the DBEs are interested by taking appropriate steps to follow up initial solicitations.

- (B) Selecting portions of the work to be performed by DBEs in order to increase the likelihood that the DBE goals will be achieved.
 - (1) Where appropriate, break out contract work items into economically feasible units to facilitate DBE participation, even when the prime contractor might otherwise prefer to perform these work items with its own forces.
 - (2) Negotiate with subcontractors to assume part of the responsibility to meet the contract DBE goal when the work to be sublet includes potential for DBE participation (2nd and 3rd tier subcontractors).
- (C) Providing interested DBEs with adequate information about the plans, specifications, and requirements of the contract in a timely manner to assist them in responding to a solicitation.
- (D)
 - (1) Negotiating in good faith with interested DBEs. It is the bidder's responsibility to make a portion of the work available to DBE subcontractors and suppliers and to select those portions of the work or material needs consistent with the available DBE subcontractors and suppliers, so as to facilitate DBE participation. Evidence of such negotiation includes the names, addresses, and telephone numbers of DBEs that were considered; a description of the information provided regarding the plans and specifications for the work selected for subcontracting; and evidence as to why additional agreements could not be reached for DBEs to perform the work.
 - (2) A bidder using good business judgment would consider a number of factors in negotiating with subcontractors, including DBE subcontractors, and would take a firm's price and capabilities as well as contract goals into consideration. However, the fact that there may be some additional costs involved in finding and using DBEs is not in itself sufficient reason for a bidder's failure to meet the contract DBE goal, as long as such costs are reasonable. Also, the ability or desire of a prime contractor to perform the work of a contract with its own organization does not relieve the bidder of the responsibility to make good faith efforts. Bidding contractors are not, however, required to accept higher quotes from DBEs if the price difference is excessive or unreasonable.
- (E) Not rejecting DBEs as being unqualified without sound reasons based on a thorough investigation of their capabilities. The bidder's standing within its industry, membership in specific groups, organizations, or associates and political or social affiliations (for example, union vs. non-union employee status) are not legitimate causes for the rejection or non-solicitation of bids in the bidder's efforts to meet the project goal.
- (F) Making efforts to assist interested DBEs in obtaining bonding, lines of credit, or insurance as required by the recipient or bidder.

- (G) Making efforts to assist interested DBEs in obtaining necessary equipment, supplies, materials, or related assistance or services.
- (H) Effectively using the services of available minority/women community organizations; minority/women contractors' groups; Federal, State, and local minority/women business assistance offices; and other organizations as allowed on a case-by-case basis to provide assistance in the recruitment and placement of DBEs. Contact within 7 days from the bid opening the Business Opportunity and Work Force Development Unit at DBE@ncdot.gov to give notification of the bidder's inability to get DBE quotes.
- (I) Any other evidence that the bidder submits which shows that the bidder has made reasonable good faith efforts to meet the DBE goal.

In addition, the Department may take into account the following:

- (1) Whether the bidder's documentation reflects a clear and realistic plan for achieving the DBE goal.
- (2) The bidders' past performance in meeting the DBE goals.
- (3) The performance of other bidders in meeting the DBE goal. For example, when the apparent successful bidder fails to meet the DBE goal, but others meet it, you may reasonably raise the question of whether, with additional reasonable efforts the apparent successful bidder could have met the goal. If the apparent successful bidder fails to meet the DBE goal, but meets or exceeds the average DBE participation obtained by other bidders, the Department may view this, in conjunction with other factors, as evidence of the apparent successful bidder having made a good faith effort.

If the Department does not award the contract to the apparent lowest responsive bidder, the Department reserves the right to award the contract to the next lowest responsive bidder that can satisfy to the Department that the DBE goal can be met or that an adequate good faith effort has been made to meet the DBE goal.

Non-Good Faith Appeal

The State Contractual Services Engineer will notify the contractor verbally and in writing of non-good faith. A contractor may appeal a determination of non-good faith made by the Goal Compliance Committee. If a contractor wishes to appeal the determination made by the Committee, they shall provide written notification to the State Contractual Services Engineer or at DBE@ncdot.gov. The appeal shall be made within 2 business days of notification of the determination of non-good faith.

Counting DBE Participation Toward Meeting DBE Goal**(A) Participation**

The total dollar value of the participation by a committed DBE will be counted toward the contract goal requirement. The total dollar value of participation by a committed DBE will be based upon the value of work actually performed by the DBE and the actual payments to DBE firms by the Contractor.

(B) Joint Checks

Prior notification of joint check use shall be required when counting DBE participation for services or purchases that involves the use of a joint check. Notification shall be through submission of Form JC-1 (*Joint Check Notification Form*) and the use of joint checks shall be in accordance with the Department's Joint Check Procedures.

(C) Subcontracts (Non-Trucking)

A DBE may enter into subcontracts. Work that a DBE subcontracts to another DBE firm may be counted toward the contract goal requirement. Work that a DBE subcontracts to a non-DBE firm does not count toward the contract goal requirement. If a DBE contractor or subcontractor subcontracts a significantly greater portion of the work of the contract than would be expected on the basis of standard industry practices, it shall be presumed that the DBE is not performing a commercially useful function. The DBE may present evidence to rebut this presumption to the Department. The Department's decision on the rebuttal of this presumption is subject to review by the Federal Highway Administration but is not administratively appealable to USDOT.

(D) Joint Venture

When a DBE performs as a participant in a joint venture, the Contractor may count toward its contract goal requirement a portion of the total value of participation with the DBE in the joint venture, that portion of the total dollar value being a distinct clearly defined portion of work that the DBE performs with its forces.

(E) Suppliers

A contractor may count toward its DBE requirement 60 percent of its expenditures for materials and supplies required to complete the contract and obtained from a DBE regular dealer and 100 percent of such expenditures from a DBE manufacturer.

(F) Manufacturers and Regular Dealers

A contractor may count toward its DBE requirement the following expenditures to DBE firms that are not manufacturers or regular dealers:

- (1) The fees or commissions charged by a DBE firm for providing a *bona fide* service, such as professional, technical, consultant, or managerial services, or for providing bonds or insurance specifically required for the performance of a DOT-assisted contract, provided the fees or commissions are determined to be reasonable and not excessive as compared with fees and commissions customarily allowed for similar services.
- (2) With respect to materials or supplies purchased from a DBE, which is neither a manufacturer nor a regular dealer, count the entire amount of fees or commissions charged for assistance in the procurement of the materials and supplies, or fees or transportation charges for the delivery of materials or supplies required on a job site (but not the cost of the materials and supplies themselves), provided the fees are determined to be reasonable and not excessive as compared with fees customarily allowed for similar services.

Commercially Useful Function

(A) DBE Utilization

The Contractor may count toward its contract goal requirement only expenditures to DBEs that perform a commercially useful function in the work of a contract. A DBE performs a commercially useful function when it is responsible for execution of the work of the contract and is carrying out its responsibilities by actually performing, managing, and supervising the work involved. To perform a commercially useful function, the DBE shall also be responsible with respect to materials and supplies used on the contract, for negotiating price, determining quality and quantity, ordering the material and installing (where applicable) and paying for the material itself. To determine whether a DBE is performing a commercially useful function, the Department will evaluate the amount of work subcontracted, industry practices, whether the amount the firm is to be paid under the contract is commensurate with the work it is actually performing and the DBE credit claimed for its performance of the work, and any other relevant factors.

(B) DBE Utilization in Trucking

The following factors will be used to determine if a DBE trucking firm is performing a commercially useful function:

- (1) The DBE shall be responsible for the management and supervision of the entire trucking operation for which it is responsible on a particular contract, and there shall not be a contrived arrangement for the purpose of meeting DBE goals.

- (2) The DBE shall itself own and operate at least one fully licensed, insured, and operational truck used on the contract.
- (3) The DBE receives credit for the total value of the transportation services it provides on the contract using trucks it owns, insures, and operates using drivers it employs.
- (4) The DBE may subcontract the work to another DBE firm, including an owner-operator who is certified as a DBE. The DBE who subcontracts work to another DBE receives credit for the total value of the transportation services the subcontracted DBE provides on the contract.
- (5) The DBE may also subcontract the work to a non-DBE firm, including from an owner-operator. The DBE who subcontracts the work to a non-DBE is entitled to credit for the total value of transportation services provided by the non-DBE subcontractor not to exceed the value of transportation services provided by DBE-owned trucks on the contract. Additional participation by non-DBE subcontractors receives credit only for the fee or commission it receives as a result of the subcontract arrangement. The value of services performed under subcontract agreements between the DBE and the Contractor will not count towards the DBE contract requirement.
- (6) A DBE may lease truck(s) from an established equipment leasing business open to the general public. The lease must indicate that the DBE has exclusive use of and control over the truck. This requirement does not preclude the leased truck from working for others during the term of the lease with the consent of the DBE, so long as the lease gives the DBE absolute priority for use of the leased truck. This type of lease may count toward the DBE's credit as long as the driver is under the DBE's payroll.
- (7) Subcontracted/leased trucks shall display clearly on the dashboard the name of the DBE that they are subcontracted/leased to and their own company name if it is not identified on the truck itself. Magnetic door signs are not permitted.

DBE Replacement

When a Contractor has relied on a commitment to a DBE firm (or an approved substitute DBE firm) to meet all or part of a contract goal requirement, the contractor shall not terminate the DBE for convenience. This includes, but is not limited to, instances in which the Contractor seeks to perform the work of the terminated subcontractor with another DBE subcontractor, a non-DBE subcontractor, or with the Contractor's own forces or those of an affiliate. A DBE may only be terminated after receiving the Engineer's written approval based upon a finding of good cause for the termination. The prime contractor must give the DBE firm five (5) calendar days to respond to the prime contractor's notice of termination and advise the prime contractor and the Department of the reasons, if any, why the firm objects to the proposed termination of its subcontract and why the Department should not approve the action.

All requests for replacement of a committed DBE firm shall be submitted to the Engineer for approval on Form RF-1 (*DBE Replacement Request*). If the Contractor fails to follow this procedure, the Contractor may be disqualified from further bidding for a period of up to 6 months.

The Contractor shall comply with the following for replacement of a committed DBE:

(A) Performance Related Replacement

When a committed DBE is terminated for good cause as stated above, an additional DBE that was submitted at the time of bid may be used to fulfill the DBE commitment. A good faith effort will only be required for removing a committed DBE if there were no additional DBEs submitted at the time of bid to cover the same amount of work as the DBE that was terminated.

If a replacement DBE is not found that can perform at least the same amount of work as the terminated DBE, the Contractor shall submit a good faith effort documenting the steps taken. Such documentation shall include, but not be limited to, the following:

- (1) Copies of written notification to DBEs that their interest is solicited in contracting the work defaulted by the previous DBE or in subcontracting other items of work in the contract.
- (2) Efforts to negotiate with DBEs for specific subbids including, at a minimum:
 - (a) The names, addresses, and telephone numbers of DBEs who were contacted.
 - (b) A description of the information provided to DBEs regarding the plans and specifications for portions of the work to be performed.
- (3) A list of reasons why DBE quotes were not accepted.
- (4) Efforts made to assist the DBEs contacted, if needed, in obtaining bonding or insurance required by the Contractor.

(B) Decertification Replacement

- (1) When a committed DBE is decertified by the Department after the SAF (*Subcontract Approval Form*) has been received by the Department, the Department will not require the Contractor to solicit replacement DBE participation equal to the remaining work to be performed by the decertified firm. The participation equal to the remaining work performed by the decertified firm will count toward the contract goal requirement.
- (2) When a committed DBE is decertified prior to the Department receiving the SAF (*Subcontract Approval Form*) for the named DBE firm, the Contractor shall take all necessary and reasonable steps to replace the DBE subcontractor with

another DBE subcontractor to perform at least the same amount of work to meet the DBE goal requirement. If a DBE firm is not found to do the same amount of work, a good faith effort must be submitted to NCDOT (see A herein for required documentation).

Changes in the Work

When the Engineer makes changes that result in the reduction or elimination of work to be performed by a committed DBE, the Contractor will not be required to seek additional participation. When the Engineer makes changes that result in additional work to be performed by a DBE based upon the Contractor's commitment, the DBE shall participate in additional work to the same extent as the DBE participated in the original contract work.

When the Engineer makes changes that result in extra work, which has more than a minimal impact on the contract amount, the Contractor shall seek additional participation by DBEs unless otherwise approved by the Engineer.

When the Engineer makes changes that result in an alteration of plans or details of construction, and a portion or all of the work had been expected to be performed by a committed DBE, the Contractor shall seek participation by DBEs unless otherwise approved by the Engineer.

When the Contractor requests changes in the work that result in the reduction or elimination of work that the Contractor committed to be performed by a DBE, the Contractor shall seek additional participation by DBEs equal to the reduced DBE participation caused by the changes.

Reports and Documentation

A SAF (*Subcontract Approval Form*) shall be submitted for all work which is to be performed by a DBE subcontractor. The Department reserves the right to require copies of actual subcontract agreements involving DBE subcontractors.

When using transportation services to meet the contract commitment, the Contractor shall submit a proposed trucking plan in addition to the SAF. The plan shall be submitted prior to beginning construction on the project. The plan shall include the names of all trucking firms proposed for use, their certification type(s), the number of trucks owned by the firm, as well as the individual truck identification numbers, and the line item(s) being performed.

Within 30 calendar days of entering into an agreement with a DBE for materials, supplies or services, not otherwise documented by the SAF as specified above, the Contractor shall furnish the Engineer a copy of the agreement. The documentation shall also indicate the percentage (60% or 100%) of expenditures claimed for DBE credit.

Reporting Disadvantaged Business Enterprise Participation

The Contractor shall provide the Engineer with an accounting of payments made to all DBE firms, including material suppliers and contractors at all levels (prime, subcontractor, or second tier subcontractor). This accounting shall be furnished to the Engineer for any given month by the end

of the following month. Failure to submit this information accordingly may result in the following action:

- (A) Withholding of money due in the next partial pay estimate; or
- (B) Removal of an approved contractor from the prequalified bidders' list or the removal of other entities from the approved subcontractors list.

While each contractor (prime, subcontractor, 2nd tier subcontractor) is responsible for accurate accounting of payments to DBEs, it shall be the prime contractor's responsibility to report all monthly and final payment information in the correct reporting manner.

Failure on the part of the Contractor to submit the required information in the time frame specified may result in the disqualification of that contractor and any affiliate companies from further bidding until the required information is submitted.

Failure on the part of any subcontractor to submit the required information in the time frame specified may result in the disqualification of that contractor and any affiliate companies from being approved for work on future DOT projects until the required information is submitted.

Contractors reporting transportation services provided by non-DBE lessees shall evaluate the value of services provided during the month of the reporting period only.

At any time, the Engineer can request written verification of subcontractor payments.

The Contractor shall report the accounting of payments through the Department's DBE Payment Tracking System.

Failure to Meet Contract Requirements

Failure to meet contract requirements in accordance with Subarticle 102-15(J) of the *2012 Standard Specifications* may be cause to disqualify the Contractor.

CERTIFICATION FOR FEDERAL-AID CONTRACTS:

(3-21-90)

SP1 G85

The prospective participant certifies, by signing and submitting this bid or proposal, to the best of his or her knowledge and belief, that:

- (A) No Federal appropriated funds have been paid or will be paid, by or on behalf of the undersigned, to any person for influencing or attempting to influence an officer or employee of any Federal agency, a Member of Congress, an officer or employee of Congress, or an employee of a Member of Congress in connection with the awarding of any Federal contract, the making of any Federal grant, the making of any Federal loan, the entering into of any cooperative agreement, and the extension, continuation, renewal, amendment, or modification of any Federal contract, grant, loan, or cooperative agreement.

- (B) If any funds other than Federal appropriated funds have been paid or will be paid to any person for influencing or attempting to influence an officer or employee of any Federal agency, a Member of Congress, an officer or employee of Congress, or an employee of a Member of Congress in connection with this Federal contract, grant, loan, or cooperative agreement, the undersigned shall complete and submit Standard Form-LLL, *Disclosure Form to Report Lobbying*, in accordance with its instructions.

This certification is a material representation of fact upon which reliance was placed when this transaction was made or entered into. Submission of this certification is a prerequisite for making or entering into this transaction imposed by *Section 1352, Title 31, U.S. Code*. Any person who fails to file the required certification shall be subject to a civil penalty of not less than \$10,000 and not more than \$100,000 for each such failure.

The prospective participant also agrees by submitting his or her bid or proposal that he or she shall require that the language of this certification be included in all lower tier subcontracts, which exceed \$100,000 and that all such subrecipients shall certify and disclose accordingly.

CONTRACTOR'S LICENSE REQUIREMENTS:

(7-1-95)

102-14

SP1 G88

If the successful bidder does not hold the proper license to perform any plumbing, heating, air conditioning, or electrical work in this contract, he will be required to sublet such work to a contractor properly licensed in accordance with *Article 2 of Chapter 87 of the General Statutes* (licensing of heating, plumbing, and air conditioning contractors) and *Article 4 of Chapter 87 of the General Statutes* (licensing of electrical contractors).

U.S. DEPARTMENT OF TRANSPORTATION HOTLINE:

(11-22-94)

108-5

SP1 G100

To report bid rigging activities call: **1-800-424-9071**

The U.S. Department of Transportation (DOT) operates the above toll-free hotline Monday through Friday, 8:00 a.m. to 5:00 p.m. eastern time. Anyone with knowledge of possible bid rigging, bidder collusion, or other fraudulent activities should use the hotline to report such activities.

The hotline is part of the DOT's continuing effort to identify and investigate highway construction contract fraud and abuse is operated under the direction of the DOT Inspector General. All information will be treated confidentially and caller anonymity will be respected.

CARGO PREFERENCE ACT:

(2-16-16)

Privately owned United States-flag commercial vessels transporting cargoes are subject to the Cargo Preference Act (CPA) of 1954 requirements and regulations found in 46 CFR 381.7. Contractors are directed to clause (b) of 46 CFR 381.7 as follows:

- (b) Contractor and Subcontractor Clauses. "Use of United States-flag vessels: The contractor agrees-
- “(1) To utilize privately owned United States-flag commercial vessels to ship at least 50 percent of the gross tonnage (computed separately for dry bulk carriers, dry cargo liners, and tankers) involved, whenever shipping any equipment, material, or commodities pursuant to this contract, to the extent such vessels are available at fair and reasonable rates for United States-flag commercial vessels.
- (2) To furnish within 20 days following the date of loading for shipments originating within the United States or within 30 working days following the date of loading for shipments originating outside the United States a legible copy of a rated, 'on-board' commercial ocean bill-of-lading in English for each shipment of cargo described in paragraph (b) (1) of this section to both the Contracting Officer (through the prime contractor in the case of subcontractor bills-of-lading) and to the Division of National Cargo, Office of Market Development, Maritime Administration, Washington, DC 20590.
- (3) To insert the substance of the provisions of this clause in all subcontracts issued pursuant to this contract."

SUBSURFACE INFORMATION:

(7-1-95)

450

SP1 G112 A

There is **no** subsurface information available on this project. The Contractor shall make his own investigation of subsurface conditions.

LOCATING EXISTING UNDERGROUND UTILITIES:

(3-20-12)

105

SP1 G115

Revise the *2012 Standard Specifications* as follows:

Page 1-43, Article 105-8, line 28, after the first sentence, add the following:

Identify excavation locations by means of pre-marking with white paint, flags, or stakes or provide a specific written description of the location in the locate request.

VALUE ENGINEERING PROPOSAL:

(05-19-15)

104

SP01 G116

Revise the *2012 Standard Specifications* as follows:

Page 1-36, Subarticle 104-12(B) Evaluation of Proposals, lines 42-44, replace the fourth sentence of the second paragraph with the following:

Pending execution of a formal supplemental agreement implementing an approved VEP and transferal of final plans (hard copy and electronic) sealed by an engineer licensed in the State of

North Carolina incorporating an approved VEP to the Resident Engineer and the State Value Management Engineer, the Contractor shall remain obligated to perform the work in accordance with the terms of the existing contract.

Page 1-37, Subarticle 104-12(D) Preliminary Review, lines 9-12, replace the first sentence of the first paragraph with the following:

Should the Contractor desire a preliminary review of a possible VEP, before expending considerable time and expense in full development, a copy of the Preliminary VEP shall be submitted to the Resident Engineer and the State Value Management Engineer at ValueManagementUnit@ncdot.gov.

Page 1-37, Subarticle 104-12(E) Final Proposal, lines 22-23, replace the first sentence of the first paragraph with the following:

A copy of the Final VEP shall be submitted by the Contractor to the Resident Engineer and the State Value Management Engineer at ValueManagementUnit@ncdot.gov.

Page 1-38, Subarticle 104-12(F) Modifications, lines 2-8, replace the first paragraph with the following:

To facilitate the preparation of revisions to contract drawings, the Contractor may purchase reproducible copies of drawings for his use through the Department's Value Management Unit. The preparation of new design drawings by or for the Contractor shall be coordinated with the appropriate Design Branch through the State Value Management Engineer. The Contractor shall provide, at no charge to the Department, one set of reproducible drawings of the approved design needed to implement the VEP. Drawings (hard copy and electronic) which are sealed by an engineer licensed in the State of North Carolina shall be submitted to the State Value Management Engineer no later than ten (10) business days after acceptance of a VEP unless otherwise permitted.

Page 1-38, Subarticle 104-12(F) Modifications, line 17, add the following at the end of the third paragraph:

Supplemental agreements executed for design-bid-build contracts shall reflect any realized savings in the corresponding line items. Supplemental agreements executed for design-build contracts shall add one line item deducting the full savings from the total contract price and one line item crediting the Contractor with 50% of the total VEP savings.

Page 1-38, Subarticle 104-12(F) Modifications, lines 45-47, replace the eighth paragraph with the following:

Unless and until a supplemental agreement is executed and issued by the Department and final plans (hard copy and electronic) sealed by an engineer licensed in the State of North Carolina incorporating an approved VEP have been provided to the Resident Engineer and the State Value Management Engineer, the Contractor shall remain obligated to perform the work in accordance with the terms of the existing contract.

RESOURCE CONSERVATION AND ENV. SUSTAINABLE PRACTICES:

(5-21-13) (Rev. 5-19-15)

104-13

SP1 G118

In accordance with North Carolina Executive Order 156, NCGS 130A-309.14(3), and NCGS 136-28.8, it is the objective of the Department to aid in the reduction of materials that become a part of our solid waste stream, to divert materials from landfills, to find ways to recycle and reuse materials, to consider and minimize, where economically feasible, the environmental impacts associated with agency land use and acquisition, construction, maintenance and facility management for the benefit of the Citizens of North Carolina.

To achieve the mission of reducing environmental impacts across the state, the Department is committed to supporting the efforts to initiate, develop and use products and construction methods that incorporate the use of recycled, solid waste products and environmentally sustainable practices in accordance with Article 104-13 of the *Standard Specifications*.

Report the quantities of reused or recycled materials either incorporated in the project or diverted from landfills and any practice that minimizes the environmental impact on the project annually on the Project Construction Reuse and Recycling Reporting Form. The Project Construction Reuse and Recycling Reporting Form and a location tool for local recycling facilities are available at:

<http://connect.ncdot.gov/resources/Environmental/Pages/North-Carolina-Recycling-Locations.aspx>.

Submit the Project Construction Reuse and Recycling Reporting Form by August 1 annually to valuemanagementunit@ncdot.gov. For questions regarding the form or reporting, please contact the State Value Management Engineer at 919-707-4810.

DOMESTIC STEEL:

(4-16-13)

106

SP1 G120

Revise the 2012 *Standard Specifications* as follows:

Page 1-49, Subarticle 106-1(B) Domestic Steel, lines 2-7, replace the first paragraph with the following:

All steel and iron products that are permanently incorporated into this project shall be produced in the United States except minimal amounts of foreign steel and iron products may be used provided the combined material cost of the items involved does not exceed 0.1% of the total amount bid for the entire project or \$2,500, whichever is greater. If invoices showing the cost of the material are not provided, the amount of the bid item involving the foreign material will be used for calculations. This minimal amount of foreign produced steel and iron products permitted for use is not applicable to high strength fasteners. Domestically produced high strength fasteners are required.

IRAN DIVESTMENT ACT:

(5-17-16)

SP01 G151

As a result of the Iran Divestment Act of 2015 (Act), Article 6E, N.C. General Statute § 147-86.55, the State Treasurer published the Final Divestment List (List) which includes the Final Divestment List-Iran, and the Parent and Subsidiary Guidance-Iran. These lists identify companies and persons engaged in investment activities in Iran and will be updated every 180 days. The List can be found at <https://www.nctreasurer.com/inside-the-department/OpenGovernment/Pages/Iran-Divestment-Act-Resources.aspx>

By submitting the Offer, the Contractor certifies that, as of the date of this bid, it is not on the then-current List created by the State Treasurer. The Contractor must notify the Department immediately if, at any time before the award of the contract, it is added to the List.

As an ongoing obligation, the Contractor must notify the Department immediately if, at any time during the contract term, it is added to the List. Consistent with § 147-86.59, the Contractor shall not contract with any person to perform a part of the work if, at the time the subcontract is signed, that person is on the then-current List.

During the term of the Contract, should the Department receive information that a person is in violation of the Act as stated above, the Department will offer the person an opportunity to respond and the Department will take action as appropriate and provided for by law, rule, or contract.

GIFTS FROM VENDORS AND CONTRACTORS:

(12-15-09)

107-1

SP1 G152

By Executive Order 24, issued by Governor Perdue, and *N.C.G.S. § 133-32*, it is unlawful for any vendor or contractor (i.e. architect, bidder, contractor, construction manager, design professional, engineer, landlord, offeror, seller, subcontractor, supplier, or vendor), to make gifts or to give favors to any State employee of the Governor's Cabinet Agencies (i.e. Administration, Commerce, Correction, Crime Control and Public Safety, Cultural Resources, Environment and Natural Resources, Health and Human Services, Juvenile Justice and Delinquency Prevention, Revenue, Transportation, and the Office of the Governor). This prohibition covers those vendors and contractors who:

- (A) Have a contract with a governmental agency; or
- (B) Have performed under such a contract within the past year; or
- (C) Anticipate bidding on such a contract in the future.

For additional information regarding the specific requirements and exemptions, vendors and contractors are encouraged to review Executive Order 24 and *N.C.G.S. § 133-32*.

Executive Order 24 also encouraged and invited other State Agencies to implement the requirements and prohibitions of the Executive Order to their agencies. Vendors and contractors should contact other State Agencies to determine if those agencies have adopted Executive Order 24.

LIABILITY INSURANCE:

(5-20-14)

SP1 G160

Revise the *2012 Standard Specifications* as follows:

Page 1-60, Article 107-15 LIABILITY INSURANCE, line 16, add the following as the second sentence of the third paragraph:

Prior to beginning services, all contractors shall provide proof of coverage issued by a workers' compensation insurance carrier, or a certificate of compliance issued by the Department of Insurance for self-insured subcontractors, irrespective of whether having regularly in service fewer than three employees.

EMPLOYMENT:

(11-15-11) (Rev. 1-17-12)

108, 102

SP1 G184

Revise the *2012 Standard Specifications* as follows:

Page 1-20, Subarticle 102-15(O), delete and replace with the following:

(O) Failure to restrict a former Department employee as prohibited by Article 108-5.

Page 1-65, Article 108-5 Character of Workmen, Methods, and Equipment, line 32, delete all of line 32, the first sentence of the second paragraph and the first word of the second sentence of the second paragraph.

STATE HIGHWAY ADMINISTRATOR TITLE CHANGE:

(9-18-12)

SP1 G185

Revise the *2012 Standard Specifications* as follows:

Replace all references to "State Highway Administrator" with "Chief Engineer".

SUBLETTING OF CONTRACT:

(11-18-2014)

108-6

SP1 G186

Revise the *2012 Standard Specifications* as follows:

Page 1-66, Article 108-6 Subletting of Contract, line 37, add the following as the second sentence of the first paragraph:

All requests to sublet work shall be submitted within 30 days of the date of availability or prior to expiration of 20% of the contract time, whichever date is later, unless otherwise approved by the Engineer.

Page 1-67, Article 108-6 Subletting of Contract, line 7, add the following as the second sentence of the fourth paragraph:

Purchasing materials for subcontractors is not included in the percentage of work required to be performed by the Contractor. If the Contractor sublets items of work but elects to purchase material for the subcontractor, the value of the material purchased will be included in the total dollar amount considered to have been sublet.

PROJECT SPECIAL PROVISIONS**ROADWAY****BURNING RESTRICTIONS:**

(7-1-95)

200, 210, 215

SP2 R05

Open burning is not permitted on any portion of the right-of-way limits established for this project. Do not burn the clearing, grubbing or demolition debris designated for disposal and generated from the project at locations within the project limits, off the project limits or at any waste or borrow sites in this county. Dispose of the clearing, grubbing and demolition debris by means other than burning, according to state or local rules and regulations.

MATERIALS:

(2-21-12) (Rev. 11-22-16)

1000, 1002, 1005, 1016, 1018, 1024, 1050, 1074, 1078, 1080, 1081, 1086, 1084, 1087, 1092

SP10 R01

Revise the *2012 Standard Specifications* as follows:

Page 10-1, Article 1000-1, DESCRIPTION, lines 9-10, replace the last sentence of the first paragraph with the following:

Type IL, IP, IS or IT blended cement may be used instead of Portland cement.

Page 10-1, Article 1000-1, DESCRIPTION, line 14, add the following:

If any change is made to the mix design, submit a new mix design (with the exception of an approved pozzolan source change).

If any major change is made to the mix design, also submit new test results showing the mix design conforms to the criteria. Define a major change to the mix design as:

- (1) A source change in coarse aggregate, fine aggregate or cement.
- (2) A pozzolan class or type change (e.g. Class F fly ash to Class C fly ash).
- (3) A quantitative change in coarse aggregate (applies to an increase or decrease greater than 5%), fine aggregate (applies to an increase or decrease greater than 5%), water (applies to an increase only), cement (applies to a decrease only), or pozzolan (applies to an increase or decrease greater than 5%).

Use materials which do not produce a mottled appearance through rusting or other staining of the finished concrete surface.

Page 10-1, Article 1000-2, MATERIALS, line 16; Page 10-8, Subarticle 1000-7(A), Materials, line 8; and Page 10-18, Article 1002-2, MATERIALS, line 9, add the following to the table of item references:

Item**Section**

Type II Blended Cement

1024-1

Page 10-1, Subarticle 1000-3(A), Composition and Design, lines 25-27, replace the second paragraph with the following:

Fly ash may be substituted for cement in the mix design up to 30% at a rate of 1.0 lb of fly ash to each pound of cement replaced.

Page 10-2, Subarticle 1000-3(A), Composition and Design, lines 12-21, delete the third paragraph through the sixth paragraph beginning with “If any change is made to the mix design, submit...” through “...(applies to a decrease only).”

Page 10-5, Table 1000-1, REQUIREMENTS FOR CONCRETE, replace with the following:

| TABLE 1000-1 REQUIREMENTS FOR CONCRETE | | | | | | | | | | | |
|---|--|----------------------------|-------------------|----------------------------|-------------------|---------------------------------------|--------------------|----------------|--------------|--------------|--------------|
| Class of Concrete | Min. Comp. Strength at 28 days | Maximum Water-Cement Ratio | | | | Consistency Max. Slump | | Cement Content | | | |
| | | Air-Entrained Concrete | | Non Air-Entrained Concrete | | Vibrated | Non-Vibrated | Vibrated | | Non-Vibrated | |
| | | Rounded Aggregate | Angular Aggregate | Rounded Aggregate | Angular Aggregate | | | Min. | Max. | Min. | Max. |
| <i>Units</i> | <i>psi</i> | | | | | <i>inch</i> | <i>inch</i> | <i>lb/cy</i> | <i>lb/cy</i> | <i>lb/cy</i> | <i>lb/cy</i> |
| AA | 4,500 | 0.381 | 0.426 | - | - | 3.5 | - | 639 | 715 | - | - |
| AA Slip Form | 4,500 | 0.381 | 0.426 | - | - | 1.5 | - | 639 | 715 | - | - |
| Drilled Pier | 4,500 | - | - | 0.450 | 0.450 | - | 5-7 dry 7-9 wet | - | - | 640 | 800 |
| A | 3,000 | 0.488 | 0.532 | 0.550 | 0.594 | 3.5 | 4 | 564 | - | 602 | - |
| B | 2,500 | 0.488 | 0.567 | 0.559 | 0.630 | 1.5 machine-placed 2.5 hand-placed | 4 | 508 | - | 545 | - |
| Sand Light-weight | 4,500 | - | 0.420 | - | - | 4 | - | 715 | - | - | - |
| Latex Modified | 3,000 7 day | 0.400 | 0.400 | - | - | 6 | - | 658 | - | - | - |
| Flowable Fill excavatable | 150 max. at 56 days | as needed | as needed | as needed | as needed | - | Flowable | - | - | 40 | 100 |
| Flowable Fill non-excavatable | 125 | as needed | as needed | as needed | as needed | - | Flowable | - | - | 100 | as needed |
| Pavement | 4,500 design, field 650 flexural, design only | 0.559 | 0.559 | - | - | 1.5 slip form 3.0 hand place | - | 526 | - | - | - |
| Precast | See Table 1077-1 | as needed | as needed | - | - | 6 | as needed | as needed | as needed | as needed | as needed |
| Prestress | per contract | See Table 1078-1 | See Table 1078-1 | - | - | 8 | - | 564 | as needed | - | - |

Page 10-6, Subarticle 1000-4(I), Use of Fly Ash, lines 36-2, replace the first paragraph with the following:

Fly ash may be substituted for cement in the mix design up to 30% at a rate of 1.0 lb of fly ash to each pound of cement replaced. Use Table 1000-1 to determine the maximum allowable water-cementitious material (cement + fly ash) ratio for the classes of concrete listed.

Page 10-7, Table 1000-3, MAXIMUM WATER-CEMENTITIOUS MATERIAL RATIO, delete the table.

Page 10-7, Article 1000-5, HIGH EARLY STRENGTH PORTLAND CEMENT CONCRETE, lines 30-31, delete the second sentence of the third paragraph.

Page 10-19, Article 1002-3, SHOTCRETE FOR TEMPORARY SUPPORT OF EXCAVATIONS, line 30, add the following at the end of Section 1002:

(H) Handling and Storing Test Panels

Notify the Area Materials Engineer when preconstruction or production test panels are made within 24 hours of shooting the panels. Field cure and protect test panels from damage in accordance with ASTM C1140 until the Department transports panels to the Materials and Tests Regional Laboratory for coring.

Page 10-23, Table 1005-1, AGGREGATE GRADATION-COARSE AGGREGATE, replace with the following:

| TABLE 1005-1 AGGREGATE GRADATION - COARSE AGGREGATE | | | | | | | | | | | | | |
|--|-----|--------|--------|--------|--------|--------|--------|-------|-------|------|-------|-------------------|--|
| Percentage of Total by Weight Passing | | | | | | | | | | | | | |
| Std. Size # | 2" | 1 1/2" | 1" | 3/4" | 1/2" | 3/8" | #4 | #8 | #10 | #16 | #40 | #200 | Remarks |
| 4 | 100 | 90-100 | 20-55 | 0-15 | - | 0-5 | - | - | - | - | - | A | Asphalt Plant Mix |
| 467M | 100 | 95-100 | - | 35-70 | - | 0-30 | 0-5 | - | - | - | - | A | Asphalt Plant Mix |
| 5 | - | 100 | 90-100 | 20-55 | 0-10 | 0-5 | - | - | - | - | - | A | AST, Sediment Control Stone |
| 57 | - | 100 | 95-100 | - | 25-60 | - | 0-10 | 0-5 | - | - | - | A | AST, Structural Concrete, Shoulder Drain Stone, Sediment Control Stone |
| 57M | - | 100 | 95-100 | - | 25-45 | - | 0-10 | 0-5 | - | - | - | A | AST, Concrete Pavement |
| 6M | - | - | 100 | 90-100 | 20-55 | 0-20 | 0-8 | - | - | - | - | A | AST |
| 67 | - | - | 100 | 90-100 | - | 20-55 | 0-10 | 0-5 | - | - | - | A | Asphalt Plant Mix, AST, Structural Concrete |
| 78M | - | - | - | 100 | 98-100 | 75-100 | 20-45 | 0-15 | - | - | - | A | Asphalt Plant Mix, AST, Structural Concrete, Weep Hole Drains |
| 14M | - | - | - | - | 100 | 98-100 | 35-70 | 5-20 | - | 0-8 | - | A | Asphalt Plant Mix, AST, Structural Concrete, Weep Hole Drains |
| 9M | - | - | - | - | 100 | 98-100 | 85-100 | 10-40 | - | 0-10 | - | A | AST |
| ABC | - | 100 | 75-97 | - | 55-80 | - | 35-55 | - | 25-45 | - | 14-30 | 4-12 ^B | Aggregate Base Course, Aggregate Stabilization |
| ABC(M) | - | 100 | 75-100 | - | 45-79 | - | 20-40 | - | 0-25 | - | - | 0-12 ^B | Maintenance Stabilization |
| Light-weight ^C | - | - | - | - | 100 | 80-100 | 5-40 | 0-20 | - | 0-10 | - | 0-2.5 | AST |

- A. See Subarticle 1005-4(A).
- B. See Subarticle 1005-4(B).
- C. For Lightweight Aggregate used in Structural Concrete, see Subarticle 1014-2(E)(6).

Page 10-39, Article 1016-3, CLASSIFICATIONS , lines 27-32, replace with the following:

Select material is clean, unweathered durable, blasted rock material obtained from an approved source. While no specific gradation is required, the below criteria will be used to evaluate the materials for visual acceptance by the Engineer:

- (A) At least 50% of the rock has a diameter of from 1.5 ft to 3 ft,
- (B) 30% of the rock ranges in size from 2” to 1.5 ft in diameter, and
- (C) Not more than 20% of the rock is less than 2” in diameter. No rippable rock will be permitted.

Page 10-40, Tables 1018-1 and 1018-2, PIEDMONT, WESTERN AND COASTAL AREA CRITERIA FOR ACCEPTANCE OF BORROW MATERIAL, under second column in both tables, replace second row with the following:

Acceptable, but not to be used in the top 3 ft of embankment or backfill

Page 10-46, Article 1024-1, PORTLAND CEMENT, line 33, add the following as the ninth paragraph:

Use Type IL blended cement that meets AASHTO M 240, except that the limestone content is limited to between 5 and 12% by weight and the constituents shall be interground. Class F fly ash can replace a portion of Type IL blended cement and shall be replaced as outlined in Subarticle 1000-4(I) for Portland cement. For mixes that contain cement with alkali content between 0.6% and 1.0% and for mixes that contain a reactive aggregate documented by the Department, use a pozzolan in the amount shown in Table 1024-1.

Page 10-46, Table 1024-1, POZZOLANS FOR USE IN PORTLAND CEMENT CONCRETE, replace with the following:

| TABLE 1024-1 | |
|--|--|
| POZZOLANS FOR USE IN PORTLAND CEMENT CONCRETE | |
| Pozzolan | Rate |
| Class F Fly Ash | 20% - 30% by weight of required cement content with 1.0 lb Class F fly ash per lb of cement replaced |
| Ground Granulated Blast Furnace Slag | 35%-50% by weight of required cement content with 1.0 lb slag per lb of cement replaced |
| Microsilica | 4%-8% by weight of required cement content with 1.0 lb microsilica per lb of cement replaced |

Page 10-47, Subarticle 1024-3(B), Approved Sources, lines 16-18, replace the second sentence of the second paragraph with the following:

Tests shall be performed by AASHTO's designated National Transportation Product Evaluation Program (NTPEP) laboratory for concrete admixture testing.

Page 10-65, Article 1050-1, GENERAL, line 41, replace the first sentence with the following:

All fencing material and accessories shall meet Section 106.

Page 10-115, Subarticle 1074-7(B), Gray Iron Castings, lines 10-11, replace the first two sentences with the following:

Supply gray iron castings meeting all facets of AASHTO M 306 excluding proof load. Proof load testing will only be required for new casting designs during the design process, and conformance to M306 loading (40,000 lb.) will be required only when noted on the design documents.

Page 10-126, Table 1078-1, REQUIREMENTS FOR CONCRETE, replace with the following:

| TABLE 1078-1 REQUIREMENTS FOR CONCRETE | | |
|---|---|--|
| Property | 28 Day Design Compressive Strength 6,000 psi or less | 28 Day Design Compressive Strength greater than 6,000 psi |
| Maximum Water/Cementitious Material Ratio | 0.45 | 0.40 |
| Maximum Slump without HRWR | 3.5" | 3.5" |
| Maximum Slump with HRWR | 8" | 8" |
| Air Content (upon discharge into forms) | 5 + 2% | 5 + 2% |

Page 10-151, Article 1080-4, INSPECTION AND SAMPLING, lines 18-22, replace (B), (C) and (D) with the following:

- (B) At least 3 panels prepared as specified in 5.5.10 of AASHTO M 300, Bullet Hole Immersion Test.
- (C) At least 3 panels of 4"x6"x1/4" for the Elcometer Adhesion Pull Off Test, ASTM D4541.
- (D) A certified test report from an approved independent testing laboratory for the Salt Fog Resistance Test, Cyclic Weathering Resistance Test, and Bullet Hole Immersion Test as specified in AASHTO M 300.
- (E) A certified test report from an approved independent testing laboratory that the product has been tested for slip coefficient and meets AASHTO M253, Class B.

Page 10-161, Subarticle 1081-1(A), Classifications, lines 29-33, delete first 3 sentences of the description for Type 2 and replace with the following:

Type 2 - A low-modulus, general-purpose adhesive used in epoxy mortar repairs. It may be used to patch spalled, cracked or broken concrete where vibration, shock or expansion and contraction are expected.

Page 10-162, Subarticle 1081-1(A), Classifications, lines 4-7, delete the second and third sentences of the description for Type 3A. **Lines 16-22**, delete Types 6A, 6B and 6C.

Page 10-162, Subarticle 1081-1(B), Requirements, lines 26-30, replace the second paragraph with the following:

For epoxy resin systems used for embedding dowel bars, threaded rods, rebar, anchor bolts and other fixtures in hardened concrete, the manufacturer shall submit test results showing that the bonding system will obtain 125% of the specified required yield strength of the fixture. Furnish certification that, for the particular bolt grade, diameter and embedment depth required, the anchor system will not fail by adhesive failure and that there is no movement of the anchor bolt. For certification and anchorage, use 3,000 psi as the minimum Portland cement concrete compressive strength used in this test. Use adhesives that meet Section 1081.

List the properties of the adhesive on the container and include density, minimum and maximum temperature application, setting time, shelf life, pot life, shear strength and compressive strength.

Page 10-163, Table 1081-1, PROPERTIES OF MIXED EPOXY RESIN SYSTEMS, replace with the following:

| Property | Type 1 | Type 2 | Type 3 | Type 3A | Type 4A | Type 4B | Type 5 |
|--|--------------|---------|--------|--------------|---------|---------|--------|
| Viscosity-Poises at 77°F ± 2°F | Gel | 10-30 | 25-75 | Gel | 40-150 | 40-150 | 1-6 |
| Spindle No. | - | 3 | 4 | -- | 4 | 4 | 2 |
| Speed (RPM) | - | 20 | 20 | -- | 10 | 10 | 50 |
| Pot Life (Minutes) | 20-50 | 30-60 | 20-50 | 5-50 | 40-80 | 40-80 | 20-60 |
| Minimum Tensile Strength at 7 days (psi) | 1,500 | 2,000 | 4,000 | 4,000 | 1,500 | 1,500 | 4,000 |
| Tensile Elongation at 7 days (%) | 30 min. | 30 min. | 2-5 | 2-5 | 5-15 | 5-15 | 2-5 |
| Min. Compressive Strength of 2" mortar cubes at 24 hours | 3,000 (Neat) | 4,000- | 6,000- | 6,000 (Neat) | 3,000 | 3,000 | 6,000 |
| Min. Compressive Strength of 2" mortar cubes at 7 days | 5,000 (Neat) | - | - | - | - | 5,000 | - |
| Maximum Water Absorption (%) | 1.5 | 1.0 | 1.0 | 1.5 | 1.0 | 1.0 | 1.0 |
| Min. Bond Strength Slant Shear Test at 14 days (psi) | 1,500 | 1,500 | 2,000 | 2,000 | 1,500 | 1,500 | 1,500 |

Page 10-164, Subarticle 1081-1(E), Prequalification, lines 31-33, replace the second sentence of the first paragraph with the following:

Manufacturers choosing to supply material for Department jobs must submit an application through the Value Management Unit with the following information for each type and brand name:

Page 10-164, Subarticle 1081-1(E)(3), line 37, replace with the following:

(3) Type of the material in accordance with Articles 1081-1 and 1081-4,

Page 10-165, Subarticle 1081-1(E)(6), line 1, in the first sentence of the first paragraph replace “AASHTO M 237” with “the specifications”.

Page 10-165, Subarticle 1081-1(E), Prequalification, line 9-10, delete the second sentence of the last paragraph.

Page 10-165, Subarticle 1081-1(F), Acceptance, line 14, in the first sentence of the first paragraph replace “Type 1” with “Type 3”.

Page 10-169, Subarticle 1081-3(G), Anchor Bolt Adhesives, delete this subarticle.

Page 10-170, Article 1081-3, HOT BITUMEN, line 9, add the following at the end of Section 1081:

1081-4 EPOXY RESIN ADHESIVE FOR BONDING TRAFFIC MARKINGS

(A) General

This section covers epoxy resin adhesive for bonding traffic markers to pavement surfaces.

(B) Classification

The types of epoxies and their uses are as shown below:

Type I – Rapid Setting, High Viscosity, Epoxy Adhesive. This type of adhesive provides rapid adherence to traffic markers to the surface of pavement.

Type II – Standard Setting, High Viscosity, Epoxy Adhesive. This type of adhesive is recommended for adherence of traffic markers to pavement surfaces when rapid set is not required.

Type III – Rapid Setting, Low Viscosity, Water Resistant, Epoxy Adhesive. This type of rapid setting adhesive, due to its low viscosity, is appropriate only for use with embedded traffic markers.

Type IV – Standard Set Epoxy for Blade Deflecting-Type Plowable Markers.

(C) Requirements

Epoxies shall conform to the requirements set forth in AASHTO M 237.

(D) Prequalification

Refer to Subarticle 1081-1(E).

(E) Acceptance

Refer to Subarticle 1081-1(F).

Page 10-173, Article 1084-2, STEEL SHEET PILES, lines 37-38, replace first paragraph with the following:

Steel sheet piles detailed for permanent applications shall be hot rolled and meet ASTM A572 or ASTM A690 unless otherwise required by the plans. Steel sheet piles shall be coated as required

by the plans. Galvanized sheet piles shall be coated in accordance with Section 1076. Metallized sheet piles shall be metallized in accordance to the Project Special Provision “Thermal Sprayed Coatings (Metallization)” with an 8 mil, 99.9% aluminum alloy coating and a 0.5 mil seal coating. Any portion of the metallized sheet piling encased in concrete shall receive a barrier coat. The barrier coat shall be an approved waterborne coating with a low-viscosity which readily absorbs into the pores of the aluminum thermal sprayed coating. The waterborne coating shall be applied at a spreading rate that results in a theoretical 1.5 mil dry film thickness. The manufacturer shall issue a letter of certification that the resin chemistry of the waterborne coating is compatible with the 99.9% aluminum thermal sprayed alloy and suitable for tidal water applications.

Page 10-174, Subarticle 1086-1(B)(1), Epoxy, lines 18-24, replace with the following:

The epoxy shall meet Article 1081-4.

The 2 types of epoxy adhesive which may be used are Type I, Rapid Setting, and Type II, Standard Setting. Use Type II when the pavement temperature is above 60°F or per the manufacturer’s recommendations whichever is more stringent. Use Type I when the pavement temperature is between 50°F and 60°F or per the manufacturer’s recommendations whichever is more stringent. Epoxy adhesive Type I, Cold Set, may be used to attach temporary pavement markers to the pavement surface when the pavement temperature is between 32°F and 50°F or per the manufacturer’s recommendations whichever is more stringent.

Page 10-175, Subarticle 1086-2(E), Epoxy Adhesives, line 27, replace “Section 1081” with “Article 1081-4”.

Page 10-177, Subarticle 1086-3(E), Epoxy Adhesives, line 22, replace “Section 1081” with “Article 1081-4”.

Page 10-179, Subarticle 1087-4(A), Composition, lines 39-41, replace the third paragraph with the following:

All intermixed and drop-on glass beads shall not contain more than 75 ppm arsenic or 200 ppm lead.

Page 10-180, Subarticle 1087-4(B), Physical Characteristics, line 8, replace the second paragraph with the following:

All intermixed and drop-on glass beads shall comply with NCGS § 136-30.2 and 23 USC § 109(r).

Page 10-181, Subarticle 1087-7(A), Intermixed and Drop-on Glass Beads, line 24, add the following after the first paragraph:

Use X-ray Fluorescence for the normal sampling procedure for intermixed and drop-on beads, without crushing, to check for any levels of arsenic and lead. If any arsenic or lead is detected, the sample shall be crushed and repeat the test using X-ray Fluorescence. If the X-ray Fluorescence test shows more than a LOD of 5 ppm, test the beads using United States Environmental Protection Agency Method 6010B, 6010C or 3052 for no more than 75 ppm arsenic or 200 ppm lead.

GROUT PRODUCTION AND DELIVERY:

(3-17-15)

1003

SP10 R20

Revise the *2012 Standard Specifications* as follows:

Replace Section 1003 with the following:

**SECTION 1003
GROUT PRODUCTION AND DELIVERY**

1003-1 DESCRIPTION

This section addresses cement grout to be used for structures, foundations, retaining walls, concrete barriers, embankments, pavements and other applications in accordance with the contract. Produce non-metallic grout composed of Portland cement and water and at the Contractor's option or as required, aggregate and pozzolans. Include chemical admixtures as required or needed. Provide sand cement or neat cement grout as required. Define "sand cement grout" as grout with only fine aggregate and "neat cement grout" as grout without aggregate.

The types of grout with their typical uses are as shown below:

Type 1 – A cement grout with only a 3-day strength requirement and a fluid consistency that is typically used for filling subsurface voids.

Type 2 – A nonshrink grout with strength, height change and flow conforming to ASTM C1107 that is typically used for foundations, ground anchors and soil nails.

Type 3 – A nonshrink grout with high early strength and freeze-thaw durability requirements that is typically used in pile blockouts, grout pockets, shear keys, dowel holes and recesses for concrete barriers and structures.

Type 4 – A neat cement grout with low strength, a fluid consistency and high fly ash content that is typically used for slab jacking.

Type 5 – A low slump, low mobility sand cement grout with minimal strength that is typically used for compaction grouting.

1003-2 MATERIALS

Refer to Division 10.

| Item | Section |
|--------------------------------------|----------------|
| Chemical Admixtures | 1024-3 |
| Fine Aggregate | 1014-1 |
| Fly Ash | 1024-5 |
| Ground Granulated Blast Furnace Slag | 1024-6 |
| Portland Cement | 1024-1 |
| Silica Fume | 1024-7 |
| Water | 1024-4 |

Do not use grout that contains soluble chlorides or more than 1% soluble sulfate. At the Contractor's option, use an approved packaged grout instead of the materials above except for water. Use packaged grouts that are on the NCDOT Approved Products List.

Use admixtures for grout that are on the NCDOT Approved Products List or other admixtures in accordance with Subarticle 1024-3(E) except do not use concrete additives or unclassified or other admixtures in Type 4 or 5 grout. Use Class F fly ash for Type 4 grout and Type II Portland cement for Type 5 grout.

Use well graded rounded aggregate with a gradation, liquid limit (LL) and plasticity index (PI) that meet Table 1003-1 for Type 5 grout. Fly ash may be substituted for a portion of the fines in the aggregate. Do not use any other pozzolans in Type 5 grout.

| Gradation | | Maximum Liquid Limit | Maximum Plasticity Index |
|--|---|---------------------------------|-------------------------------------|
| Sieve Designation per AASHTO M 92 | Percentage Passing (% by weight) | | |
| 3/8" | 100 | N/A | N/A |
| No. 4 | 70 – 95 | | |
| No. 8 | 50 – 90 | | |
| No. 16 | 30 – 80 | | |
| No. 30 | 25 – 70 | | |
| No. 50 | 20 – 50 | | |
| No. 100 | 15 – 40 | | |
| No. 200 | 10 – 30 | 25 | 10 |

1003-3 COMPOSITION AND DESIGN

When using an approved packaged grout, a grout mix design submittal is not required. Otherwise, submit proposed grout mix designs for each grout mix to be used in the work. Mixes for all grout shall be designed by a Certified Concrete Mix Design Technician or an Engineer licensed by the State of North Carolina. Mix proportions shall be determined by a testing laboratory approved by the Department. Base grout mix designs on laboratory trial batches that meet Table 1003-2 and this section. With permission, the Contractor may

use a quantity of chemical admixture within the range shown on the current list of approved admixtures maintained by the Materials and Tests Unit.

Submit grout mix designs in terms of saturated surface dry weights on Materials and Tests Form 312U at least 35 days before proposed use. Adjust batch proportions to compensate for surface moisture contained in the aggregates at the time of batching. Changes in the saturated surface dry mix proportions will not be permitted unless revised grout mix designs have been submitted to the Engineer and approved.

Accompany Materials and Tests Form 312U with a listing of laboratory test results of compressive strength, density and flow or slump and if applicable, aggregate gradation, durability and height change. List the compressive strength of at least three 2" cubes at the age of 3 and 28 days.

The Engineer will review the grout mix design for compliance with the contract and notify the Contractor as to its acceptability. Do not use a grout mix until written notice has been received. Acceptance of the grout mix design or use of approved packaged grouts does not relieve the Contractor of his responsibility to furnish a product that meets the contract. Upon written request from the Contractor, a grout mix design accepted and used satisfactorily on any Department project may be accepted for use on other projects.

Perform laboratory tests in accordance with the following test procedures:

| Property | Test Method |
|----------------------------------|---|
| Aggregate Gradation ^A | AASHTO T 27 |
| Compressive Strength | AASHTO T 106 |
| Density (Unit Weight) | AASHTO T 121, AASHTO T 133 ^B , ANSI/API R ^C 13B-1 ^B (Section 4, Mud Balance) |
| Durability | AASHTO T 161 ^D |
| Flow | ASTM C939 (Flow Cone) |
| Height Change | ASTM C1090 ^E |
| Slump | AASHTO T 119 |

- A.** Applicable to grout with aggregate.
- B.** Applicable to Neat Cement Grout.
- C.** American National Standards Institute/American Petroleum Institute Recommended Practice.
- D.** Procedure A (Rapid Freezing and Thawing in Water) required.
- E.** Moist room storage required.

1003-4 GROUT REQUIREMENTS

Provide grout types in accordance with the contract. Use grouts with properties that meet Table 1003-2. The compressive strength of the grout will be considered the average compressive strength test results of three 2" cubes at each age. Make cubes that meet AASHTO T 106 from the grout delivered for the work or mixed on-site. Make cubes at

such frequencies as the Engineer may determine and cure them in accordance with AASHTO T 106.

| Type of Grout | Minimum Compressive Strength at | | Height Change at 28 days | Flow ^A /Slump ^B | Minimum Durability Factor |
|----------------|---------------------------------|-----------|--------------------------|---|---------------------------|
| | 3 days | 28 days | | | |
| 1 | 3,000 psi | – | – | 10 – 30 sec | – |
| 2 | Table 1 ^C | | | Fluid Consistency ^C | – |
| 3 | 5,000 psi | – | 0 – 0.2% | Per Accepted Grout Mix Design/ Approved Packaged Grout | 80 |
| 4 ^D | 600 psi | 1,500 psi | – | 10 – 26 sec | – |
| 5 | – | 500 psi | – | 1 – 3" | – |

A. Applicable to Type 1 through 4 grouts.

B. Applicable to Type 5 grout.

C. ASTM C1107.

D. Use Type 4 grout with proportions by volume of 1 part cement and 3 parts fly ash.

1003-5 TEMPERATURE REQUIREMENTS

When using an approved packaged grout, follow the manufacturer's instructions for grout and air temperature at the time of placement. Otherwise, the grout temperature at the time of placement shall be not less than 50°F nor more than 90°F. Do not place grout when the air temperature measured at the location of the grouting operation in the shade away from artificial heat is below 40°F.

1003-6 ELAPSED TIME FOR PLACING GROUT

Agitate grout continuously before placement. Regulate the delivery so the maximum interval between the placing of batches at the work site does not exceed 20 minutes. Place grout before exceeding the times in Table 1003-3. Measure the elapsed time as the time between adding the mixing water to the grout mix and placing the grout.

| TABLE 1003-3 ELAPSED TIME FOR PLACING GROUT (with continuous agitation) | | |
|--|--|---|
| Air or Grout Temperature, Whichever is Higher | Maximum Elapsed Time | |
| | No Retarding Admixture Used | Retarding Admixture Used |
| 90°F or above | 30 minutes | 1 hr. 15 minutes |
| 80°F through 89°F | 45 minutes | 1 hr. 30 minutes |
| 79°F or below | 60 minutes | 1 hr. 45 minutes |

1003-7 MIXING AND DELIVERY

Use grout free of any lumps and undispersed cement. When using an approved packaged grout, mix grout in accordance with the manufacturer's instructions. Otherwise, comply with Articles 1000-8 through 1000-12 to the extent applicable for grout instead of concrete.

TRUCK MOUNTED CHANGEABLE MESSAGE SIGNS:

(8-21-12)

1101.02

SP11 R10

Revise the *2012 Roadway Standard Drawings* as follows:

Drawing No. 1101.02, Sheet 12, TEMPORARY LANE CLOSURES, replace General Note #11 with the following:

11- TRUCK MOUNTED CHANGEABLE MESSAGE SIGNS (TMCMS) USED ON SHADOW VEHICLES FOR "IN LANE" ACTIVITIES SHALL BE A MINIMUM OF 43" X 73". THE DISPLAY PANEL SHALL HAVE FULL MATRIX CAPABILITY WITH THE CAPABILITY TO PROVIDE 2 MESSAGE LINES WITH 7 CHARACTERS PER LINE WITH A MINIMUM CHARACTER HEIGHT OF 18". FOR ADDITIONAL MESSAGING, CONTACT THE WORK ZONE TRAFFIC CONTROL SECTION.

12- TMCMS USED FOR ADVANCED WARNING ON VEHICLES LOCATED ON THE SHOULDER MAY BE SMALLER THAN 43" X 73". THE DISPLAY PANEL SHALL HAVE THE CAPABILITY TO PROVIDE 2 MESSAGE LINES WITH 7 CHARACTERS PER LINE WITH A MINIMUM CHARACTER HEIGHT OF 18". FOR ADDITIONAL MESSAGING, CONTACT THE WORK ZONE TRAFFIC CONTROL SECTION.

Drawing No. 1101.02, Sheet 13, TEMPORARY LANE CLOSURES, replace General Note #12 with the following:

12- TRUCK MOUNTED CHANGEABLE MESSAGE SIGNS (TMCMS) USED ON SHADOW VEHICLES FOR "IN LANE" ACTIVITIES SHALL BE A MINIMUM OF 43" X 73". THE DISPLAY PANEL SHALL HAVE FULL MATRIX CAPABILITY WITH THE CAPABILITY TO PROVIDE 2 MESSAGE LINES WITH 7 CHARACTERS PER LINE WITH A MINIMUM CHARACTER HEIGHT OF 18". FOR ADDITIONAL MESSAGING, CONTACT THE WORK ZONE TRAFFIC CONTROL SECTION.

13- TMCMS USED FOR ADVANCED WARNING ON VEHICLES LOCATED ON THE SHOULDER MAY BE SMALLER THAN 43" X 73". THE DISPLAY PANEL SHALL HAVE THE CAPABILITY TO PROVIDE 2 MESSAGE LINES WITH 7 CHARACTERS PER LINE WITH A MINIMUM CHARACTER HEIGHT OF 18". FOR ADDITIONAL MESSAGING, CONTACT THE WORK ZONE TRAFFIC CONTROL SECTION.

STANDARD SPECIAL PROVISION
AVAILABILITY OF FUNDS – TERMINATION OF CONTRACTS

(5-20-08)

Z-2

General Statute 143C-6-11. (h) Highway Appropriation is hereby incorporated verbatim in this contract as follows:

(h) Amounts Encumbered. – Transportation project appropriations may be encumbered in the amount of allotments made to the Department of Transportation by the Director for the estimated payments for transportation project contract work to be performed in the appropriation fiscal year. The allotments shall be multiyear allotments and shall be based on estimated revenues and shall be subject to the maximum contract authority contained in *General Statute 143C-6-11(c)*. Payment for transportation project work performed pursuant to contract in any fiscal year other than the current fiscal year is subject to appropriations by the General Assembly. Transportation project contracts shall contain a schedule of estimated completion progress, and any acceleration of this progress shall be subject to the approval of the Department of Transportation provided funds are available. The State reserves the right to terminate or suspend any transportation project contract, and any transportation project contract shall be so terminated or suspended if funds will not be available for payment of the work to be performed during that fiscal year pursuant to the contract. In the event of termination of any contract, the contractor shall be given a written notice of termination at least 60 days before completion of scheduled work for which funds are available. In the event of termination, the contractor shall be paid for the work already performed in accordance with the contract specifications.

Payment will be made on any contract terminated pursuant to the special provision in accordance with Subarticle 108-13(E) of the *2012 Standard Specifications*.

STANDARD SPECIAL PROVISION**ERRATA**

(1-17-12) (Rev. 04-21-15)

Z-4

Revise the 2012 *Standard Specifications* as follows:

Division 2

Page 2-7, line 31, Article 215-2 Construction Methods, replace “Article 107-26” with “Article 107-25”.

Page 2-17, Article 226-3, Measurement and Payment, line 2, delete “pipe culverts,”.

Page 2-20, Subarticle 230-4(B), Contractor Furnished Sources, change references as follows:
Line 1, replace “(4) Buffer Zone” with “(c) Buffer Zone”; **Line 12**, replace “(5) Evaluation for Potential Wetlands and Endangered Species” with “(d) Evaluation for Potential Wetlands and Endangered Species”; and **Line 33**, replace “(6) Approval” with “(4) Approval”.

Division 3

Page 3-1, after line 15, Article 300-2 Materials, replace “1032-9(F)” with “1032-6(F)”.

Division 4

Page 4-77, line 27, Subarticle 452-3(C) Concrete Coping, replace “sheet pile” with “reinforcement”.

Division 6

Page 6-7, line 31, Article 609-3 Field Verification of Mixture and Job Mix Formula Adjustments, replace “30” with “45”.

Page 6-10, line 42, Subarticle 609-6(C)(2), replace “Subarticle 609-6(E)” with “Subarticle 609-6(D)”.

Page 6-11, Table 609-1 Control Limits, replace “Max. Spec. Limit” for the Target Source of $P_{0.075}/P_{be}$ Ratio with “1.0”.

Page 6-40, Article 650-2 Materials, replace “Subarticle 1012-1(F)” with “Subarticle 1012-1(E)”

Division 7

Page 7-1, Article 700-3, CONCRETE HAULING EQUIPMENT, line 33, replace “competition” with “completion”.

Division 8

Page 8-23, line 10, Article 838-2 Materials, replace “Portland Cement Concrete, Class B” with “Portland Cement Concrete, Class A”.

Division 10

Page 10-166, Article 1081-3 Hot Bitumen, replace “Table 1081-16” with “Table 1081-2”, replace “Table 1081-17” with “Table 1081-3”, and replace “Table 1081-18” with “Table 1081-4”.

Division 12

Page 12-7, Table 1205-3, add “FOR THERMOPLASTIC” to the end of the title.

Page 12-8, Subarticle 1205-5(B), line 13, replace “Table 1205-2” with “Table 1205-4”.

Page 12-8, Table 1205-4 and 1205-5, replace “THERMOPLASTIC” in the title of these tables with “POLYUREA”.

Page 12-9, Subarticle 1205-6(B), line 21, replace “Table 1205-4” with “Table 1205-6”.

Page 12-11, Subarticle 1205-8(C), line 25, replace “Table 1205-5” with “Table 1205-7”.

Division 15

Page 15-4, Subarticle 1505-3(F) Backfilling, line 26, replace “Subarticle 235-4(C)” with “Subarticle 235-3(C)”.

Page 15-6, Subarticle 1510-3(B), after line 21, replace the allowable leakage formula with the following: $W=LD\sqrt{P} \div 148,000$

Page 15-6, Subarticle 1510-3(B), line 32, delete “may be performed concurrently or” and replace with “shall be performed”.

Page 15-17, Subarticle 1540-3(E), line 27, delete “Type 1”.

Division 17

Page 17-26, line 42, Subarticle 1731-3(D) Termination and Splicing within Interconnect Center, delete this subarticle.

Revise the *2012 Roadway Standard Drawings* as follows:

1633.01 Sheet 1 of 1, English Standard Drawing for Matting Installation, replace “1633.01” with “1631.01”.

STANDARD SPECIAL PROVISION**PLANT AND PEST QUARANTINES****(Imported Fire Ant, Gypsy Moth, Witchweed, Emerald Ash Borer, And Other Noxious Weeds)**

(3-18-03) (Rev. 12-20-16)

Z-04a

Within Quarantined Area

This project may be within a county regulated for plant and/or pests. If the project or any part of the Contractor's operations is located within a quarantined area, thoroughly clean all equipment prior to moving out of the quarantined area. Comply with federal/state regulations by obtaining a certificate or limited permit for any regulated article moving from the quarantined area.

Originating in a Quarantined County

Obtain a certificate or limited permit issued by the N.C. Department of Agriculture/United States Department of Agriculture. Have the certificate or limited permit accompany the article when it arrives at the project site.

Contact

Contact the N.C. Department of Agriculture/United States Department of Agriculture at 1-800-206-9333, 919-707-3730, or <http://www.ncagr.gov/plantindustry/> to determine those specific project sites located in the quarantined area or for any regulated article used on this project originating in a quarantined county.

Regulated Articles Include

1. Soil, sand, gravel, compost, peat, humus, muck, and decomposed manure, separately or with other articles. This includes movement of articles listed above that may be associated with cut/waste, ditch pulling, and shoulder cutting.
2. Plants with roots including grass sod.
3. Plant crowns and roots.
4. Bulbs, corms, rhizomes, and tubers of ornamental plants.
5. Hay, straw, fodder, and plant litter of any kind.
6. Clearing and grubbing debris.
7. Used agricultural cultivating and harvesting equipment.
8. Used earth-moving equipment.
9. Any other products, articles, or means of conveyance, of any character, if determined by an inspector to present a hazard of spreading imported fire ant, gypsy moth, witchweed, emerald ash borer, or other noxious weeds.

STANDARD SPECIAL PROVISION**AWARD OF CONTRACT**

(6-28-77)(Rev 2/16/2016)

Z-6

“The North Carolina Department of Transportation, in accordance with the provisions of *Title VI of the Civil Rights Act of 1964* (78 Stat. 252) and the Regulations of the Department of Transportation (*49 C.F.R., Part 21*), issued pursuant to such act, hereby notifies all bidders that it will affirmatively insure that the contract entered into pursuant to this advertisement will be awarded to the lowest responsible bidder without discrimination on the ground of race, color, or national origin”.

TITLE VI AND NONDISCRIMINATION**I. Title VI Assurance**

During the performance of this contract, the contractor, for itself, its assignees and successors in interest (hereinafter referred to as the "contractor") agrees as follows:

(1) Compliance with Regulations: The contractor shall comply with the Regulation relative to nondiscrimination in Federally-assisted programs of the Department of Transportation (hereinafter, "DOT") Title 49, Code of Federal Regulations, Part 21, as they may be amended from time to time, (hereinafter referred to as the Regulations), which are herein incorporated by reference and made a part of this contract.

(2) Nondiscrimination: The Contractor, with regard to the work performed by it during the contract, shall not discriminate on the grounds of race, color, or national origin in the selection and retention of subcontractors, including procurements of materials and leases of equipment. The contractor shall not participate either directly or indirectly in the discrimination prohibited by section 21.5 of the Regulations, including employment practices when the contract covers a program set forth in Appendix B of the Regulations.

(3) Solicitations for Subcontractors, Including Procurements of Materials and Equipment: In all solicitations either by competitive bidding or negotiation made by the contractor for work to be performed under a subcontract, including procurements of materials or leases of equipment, each potential subcontractor or supplier shall be notified by the contractor of the contractor's obligations under this contract and the Regulations relative to nondiscrimination on the grounds of race, color, or national origin.

(4) Information and Reports: The contractor shall provide all information and reports required by the Regulations or directives issued pursuant thereto, and shall permit access to its books, records, accounts, other sources of information, and its facilities as may be determined by the North Carolina Department of Transportation (NCDOT) or the Federal Highway Administration (FHWA) to be pertinent to ascertain compliance with such Regulations, orders and instructions. Where any information required of a contractor is in the exclusive possession of another who fails or refuses to furnish this information the contractor shall so certify to the NCDOT, or the FHWA as appropriate, and shall set forth what efforts it has made to obtain the information.

(5) Sanctions for Noncompliance: In the event of the contractor's noncompliance with the nondiscrimination provisions of this contract, the NCDOT shall impose such contract sanctions as it or the FHWA may determine to be appropriate, including, but not limited to:

- (a) Withholding of payments to the contractor under the contract until the contractor complies, and/or
- (b) Cancellation, termination or suspension of the contract, in whole or in part.

(6) Incorporation of Provisions: The contractor shall include the provisions of paragraphs (1) through (6) in every subcontract, including procurements of materials and leases of equipment, unless exempt by the Regulations, or directives issued pursuant thereto.

The contractor shall take such action with respect to any subcontractor procurement as the NCDOT or the FHWA may direct as a means of enforcing such provisions including sanctions for noncompliance: provided, however, that, in the event a contractor becomes involved in, or is threatened with, litigation with a subcontractor or supplier as a result of such direction, the contractor may request the NCDOT to enter into such litigation to protect the interests of the NCDOT, and, in addition, the contractor may request the United States to enter into such litigation to protect the interests of the United States.

II. Title VI Nondiscrimination Program

Title VI of the 1964 Civil Rights Act, 42 U.S.C. 2000d, provides that: "No person in the United States shall, on the grounds of race, color, or national origin, be excluded from participation in, be denied the benefits of, or be subjected to discrimination under any program or activity receiving Federal financial assistance." The broader application of nondiscrimination law is found in other statutes, executive orders, and regulations (see Section III, Pertinent Nondiscrimination Authorities), which provide additional protections based on age, sex, disability and religion. In addition, the 1987 Civil Rights Restoration Act extends nondiscrimination coverage to all programs and activities of federal-aid recipients and contractors, including those that are not federally-funded.

Nondiscrimination Assurance

The North Carolina Department of Transportation (NCDOT) hereby gives assurance that no person shall on the ground of race, color, national origin, sex, age, and disability, be excluded from participation in, be denied the benefits of, or be otherwise subjected to discrimination under any program or activity conducted by the recipient, as provided by Title VI of the Civil Rights Act of 1964, the Civil Rights Restoration Act of 1987, and any other related Civil Rights authorities, whether those programs and activities are federally funded or not.

Obligation

During the performance of this contract, the Contractor and its subcontractors are responsible for complying with NCDOT's Title VI Program. The Contractor must ensure that NCDOT's Notice of Nondiscrimination is posted in conspicuous locations accessible to all employees and subcontractors on the jobsite, along with the Contractor's own Equal Employment Opportunity (EEO) Policy Statement. The Contractor shall physically incorporate this "**TITLE VI AND NONDISCRIMINATION**" language, in its entirety, into all its subcontracts on federally-assisted and state-funded NCDOT-owned projects, and ensure its inclusion by subcontractors into all subsequent lower tier subcontracts. The Contractor and its subcontractors shall also physically incorporate the **FHWA-1273**, in its entirety, into all subcontracts and subsequent lower tier subcontracts on Federal-aid highway construction contracts only. The Contractor is also

responsible for making its subcontractors aware of NCDOT's Discrimination Complaints Process, as follows:

FILING OF COMPLAINTS

1. **Applicability** – These complaint procedures apply to the beneficiaries of the NCDOT's programs, activities, and services, including, but not limited to, members of the public, contractors, subcontractors, consultants, and other sub-recipients of federal and state funds.
2. **Eligibility** – Any person or class of persons who believes he/she has been subjected to discrimination or retaliation prohibited by any of the Civil Rights authorities, based upon race, color, sex, age, national origin, or disability, may file a written complaint with NCDOT's Civil Rights office. The law prohibits intimidation or retaliation of any sort. The complaint may be filed by the affected individual or a representative, and must be in writing.
3. **Time Limits and Filing Options** – A complaint must be filed no later than 180 calendar days after the following:
 - The date of the alleged act of discrimination; or
 - The date when the person(s) became aware of the alleged discrimination; or
 - Where there has been a continuing course of conduct, the date on which that conduct was discontinued or the latest instance of the conduct.

Title VI and other discrimination complaints may be submitted to the following entities:

- **North Carolina Department of Transportation**, Office of Equal Opportunity & Workforce Services (EOWS), External Civil Rights Section, 1511 Mail Service Center, Raleigh, NC 27699-1511; 919-508-1808 or toll free 800-522-0453
 - **US Department of Transportation**, Departmental Office of Civil Rights, External Civil Rights Programs Division, 1200 New Jersey Avenue, SE, Washington, DC 20590; 202-366-4070
 - Federal Highway Administration**, North Carolina Division Office, 310 New Bern Avenue, Suite 410, Raleigh, NC 27601, 919-747-7010
 - Federal Highway Administration**, Office of Civil Rights, 1200 New Jersey Avenue, SE, 8th Floor, E81-314, Washington, DC 20590, 202-366-0693 / 366-0752
 - Federal Transit Administration**, Office of Civil Rights, ATTN: Title VI Program Coordinator, East Bldg. 5th Floor – TCR, 1200 New Jersey Avenue, SE, Washington, DC 20590
 - Federal Aviation Administration**, Office of Civil Rights, 800 Independence Avenue, SW, Washington, DC 20591, 202-267-3258
 - **US Department of Justice**, Special Litigation Section, Civil Rights Division, 950 Pennsylvania Avenue, NW, Washington, DC 20530, 202-514-6255 or toll free 877-218-5228
4. **Format for Complaints** – Complaints must be in **writing** and **signed** by the complainant(s) or a representative and include the complainant's name, address, and telephone number. Complaints received by fax or e-mail will be acknowledged and processed. Allegations received by telephone will be reduced to writing and provided to the complainant for confirmation or revision before processing. Complaints will be accepted in other languages including Braille.
 5. **Discrimination Complaint Form** – Contact NCDOT EOWS at the phone number above to receive a full copy of the Discrimination Complaint Form and procedures.

- 6. Complaint Basis** – Allegations must be based on issues involving race, color, national origin, sex, age, or disability. The term “basis” refers to the complainant’s membership in a protected group category. Contact this office to receive a Discrimination Complaint Form.

| Protected Categories | Definition | Examples | Applicable Statutes and Regulations | |
|----------------------|--|--|--|--|
| | | | FHWA | FTA |
| Race | An individual belonging to one of the accepted racial groups; or the perception, based usually on physical characteristics that a person is a member of a racial group | Black/African American, Hispanic/Latino, Asian, American Indian/Alaska Native, Native Hawaiian/Pacific Islander, White | Title VI of the Civil Rights Act of 1964; 49 CFR Part 21; 23 CFR 200 | Title VI of the Civil Rights Act of 1964; 49 CFR Part 21; Circular 4702.1B |
| Color | Color of skin, including shade of skin within a racial group | Black, White, brown, yellow, etc. | | |
| National Origin | Place of birth. Citizenship is not a factor. Discrimination based on language or a person’s accent is also covered. | Mexican, Cuban, Japanese, Vietnamese, Chinese | | |
| Sex | Gender | Women and Men | 1973 Federal-Aid Highway Act | Title IX of the Education Amendments of 1972 |
| Age | Persons of any age | 21 year old person | Age Discrimination Act of 1975 | |
| Disability | Physical or mental impairment, permanent or temporary, or perceived. | Blind, alcoholic, paraplegic, epileptic, diabetic, arthritic | Section 504 of the Rehabilitation Act of 1973; Americans with Disabilities Act of 1990 | |

III. Pertinent Nondiscrimination Authorities

During the performance of this contract, the contractor, for itself, its assignees, and successors in interest agrees to comply with the following non-discrimination statutes and authorities, including, but not limited to:

- Title VI of the Civil Rights Act of 1964 (42 U.S.C. § 2000d *et seq.*, 78 stat. 252), (prohibits discrimination on the basis of race, color, national origin); and 49 CFR Part 21.
- The Uniform Relocation Assistance and Real Property Acquisition Policies Act of 1970, (42 U.S.C. § 4601), (prohibits unfair treatment of persons displaced or whose property has been acquired because of Federal or Federal-aid programs and projects);
- Federal-Aid Highway Act of 1973, (23 U.S.C. § 324 *et seq.*), (prohibits discrimination on the basis of sex);
- Section 504 of the Rehabilitation Act of 1973, (29 U.S.C. § 794 *et seq.*), as amended, (prohibits discrimination on the basis of disability); and 49 CFR Part 27;

- The Age Discrimination Act of 1975, as amended, (42 U.S.C. § 6101 *et seq.*), (prohibits discrimination on the basis of age);
- Airport and Airway Improvement Act of 1982, (49 USC § 471, Section 47123), as amended, (prohibits discrimination based on race, creed, color, national origin, or sex);
- The Civil Rights Restoration Act of 1987, (PL 100-209), (Broadened the scope, coverage and applicability of Title VI of the Civil Rights Act of 1964, The Age Discrimination Act of 1975 and Section 504 of the Rehabilitation Act of 1973, by expanding the definition of the terms “programs or activities” to include all of the programs or activities of the Federal-aid recipients, sub-recipients and contractors, whether such programs or activities are Federally funded or not);
- Titles II and III of the Americans with Disabilities Act, which prohibit discrimination on the basis of disability in the operation of public entities, public and private transportation systems, places of public accommodation, and certain testing entities (42 U.S.C. §§ 12131 – 12189) as implemented by Department of Transportation regulations at 49 C.F.R. parts 37 and 38;
- The Federal Aviation Administration’s Non-discrimination statute (49 U.S.C. § 47123) (prohibits discrimination on the basis of race, color, national origin, and sex);
- Executive Order 12898, Federal Actions to Address Environmental Justice in Minority Populations and Low-Income Populations, which ensures discrimination against minority populations by discouraging programs, policies, and activities with disproportionately high and adverse human health or environmental effects on minority and low-income populations;
- Executive Order 13166, Improving Access to Services for Persons with Limited English Proficiency, and resulting agency guidance, national origin discrimination includes discrimination because of limited English proficiency (LEP). To ensure compliance with Title VI, you must take reasonable steps to ensure that LEP persons have meaningful access to your programs (70 Fed. Reg. at 74087 to 74100);
- Title IX of the Education Amendments of 1972, as amended, which prohibits you from discriminating because of sex in education programs or activities (20 U.S.C. 1681 *et seq.*).
- Title VII of the Civil Rights Act of 1964 (42 U.S.C. § 2000e *et seq.*, Pub. L. 88-352), (prohibits employment discrimination on the basis of race, color, religion, sex, or national origin);
- 49 CFR Part 26, regulation to ensure nondiscrimination in the award and administration of DOT-assisted contracts in the Department's highway, transit, and airport financial assistance programs, as regards the use of Disadvantaged Business Enterprises (DBEs);
- Form FHWA-1273, “Required Contract Provisions,” a collection of contract provisions and proposal notices that are generally applicable to *all Federal-aid construction projects* and must be made a part of, and physically incorporated into, *all federally-assisted contracts*, as well as appropriate subcontracts and purchase orders, particularly Sections II (Nondiscrimination) and III (Nonsegregated Facilities).

STANDARD SPECIAL PROVISION**MINORITY AND FEMALE EMPLOYMENT REQUIREMENTS**

Z-7

NOTICE OF REQUIREMENTS FOR AFFIRMATIVE ACTION TO ENSURE EQUAL EMPLOYMENT OPPORTUNITY (*EXECUTIVE NUMBER 11246*)

1. The goals and timetables for minority and female participation, expressed in percentage terms for the Contractor's aggregate workforce in each trade on all construction work in the covered area, see as shown on the attached sheet entitled "Employment Goals for Minority and Female participation".

These goals are applicable to all the Contractor's construction work (whether or not it is Federal or federally assisted) performed in the covered area. If the Contractor performs construction work in a geographical area located outside of the covered area, it shall apply the goals established for such geographical area where the work is actually performed. With regard to this second area, the Contractor also is subject to the goals for both its federally involved and nonfederally involved construction.

The Contractor's compliance with the Executive Order and the regulations in *41 CFR Part 60-4* shall be based on its implementation of the Equal Opportunity Clause, specific affirmative action obligations required by the specifications set forth in *41 CFR 60-4.3(a)*, and its effort to meet the goals. The hours of minority and female employment and training must be substantially uniform throughout the length of the contract, and in each trade and the Contractor shall make a good faith effort to employ minorities and women evenly on each of its projects. The transfer of minority or female employees or trainees from Contractor to Contractor or from project to project or the sole purpose of meeting the Contractor's goals shall be a violation of the contract, the executive Order and the regulations in *41 CFR Part 60-4*. Compliance with the goals will be measured against the total work hours performed.

2. As used in this Notice and in the contract resulting from this solicitation, the "covered area" is the county or counties shown on the cover sheet of the proposal form and contract.

**EMPLOYMENT GOALS FOR MINORITY
AND FEMALE PARTICIPATION**

Economic Areas

Area 023 29.7%

Bertie County
Camden County
Chowan County
Gates County
Hertford County
Pasquotank County
Perquimans County

Area 024 31.7%

Beaufort County
Carteret County
Craven County
Dare County
Edgecombe County
Green County
Halifax County
Hyde County
Jones County
Lenoir County
Martin County
Nash County
Northampton County
Pamlico County
Pitt County
Tyrrell County
Washington County
Wayne County
Wilson County

Area 025 23.5%

Columbus County
Duplin County
Onslow County
Pender County

Area 026 33.5%

Bladen County
Hoke County
Richmond County
Robeson County
Sampson County
Scotland County

Area 027 24.7%

Chatham County
Franklin County
Granville County
Harnett County
Johnston County
Lee County
Person County
Vance County
Warren County

Area 028 15.5%

Alleghany County
Ashe County
Caswell County
Davie County
Montgomery County
Moore County
Rockingham County
Surry County
Watauga County
Wilkes County

Area 029 15.7%

Alexander County
Anson County
Burke County
Cabarrus County
Caldwell County
Catawba County
Cleveland County
Iredell County
Lincoln County
Polk County
Rowan County
Rutherford County
Stanly County

Area 0480 8.5%

Buncombe County
Madison County

Area 030 6.3%

Avery County
Cherokee County
Clay County
Graham County
Haywood County
Henderson County
Jackson County
McDowell County
Macon County
Mitchell County
Swain County
Transylvania County
Yancey County

SMSA Areas

Area 5720 26.6%

Currituck County

Area 9200 20.7%

Brunswick County

New Hanover County

Area 2560 24.2%

Cumberland County

Area 6640 22.8%

Durham County

Orange County

Wake County

Area 1300 16.2%

Alamance County

Area 3120 16.4%

Davidson County

Forsyth County

Guilford County

Randolph County

Stokes County

Yadkin County

Area 1520 18.3%

Gaston County

Mecklenburg County

Union County

Goals for Female

Participation in Each Trade

(Statewide) 6.9%

STANDARD SPECIAL PROVISION**REQUIRED CONTRACT PROVISIONS FEDERAL - AID CONSTRUCTION CONTRACTS**

FHWA - 1273 Electronic Version - May 1, 2012

Z-8

- I. General
- II. Nondiscrimination
- III. Nonsegregated Facilities
- IV. Davis-Bacon and Related Act Provisions
- V. Contract Work Hours and Safety Standards Act Provisions
- VI. Subletting or Assigning the Contract
- VII. Safety: Accident Prevention
- VIII. False Statements Concerning Highway Projects
- IX. Implementation of Clean Air Act and Federal Water Pollution Control Act
- X. Compliance with Governmentwide Suspension and Debarment Requirements
- XI. Certification Regarding Use of Contract Funds for Lobbying

ATTACHMENTS

- A. Employment and Materials Preference for Appalachian Development Highway System or Appalachian Local Access Road Contracts (included in Appalachian contracts only)

I. GENERAL

1. Form FHWA-1273 must be physically incorporated in each construction contract funded under Title 23 (excluding emergency contracts solely intended for debris removal). The contractor (or subcontractor) must insert this form in each subcontract and further require its inclusion in all lower tier subcontracts (excluding purchase orders, rental agreements and other agreements for supplies or services).
The applicable requirements of Form FHWA-1273 are incorporated by reference for work done under any purchase order, rental agreement or agreement for other services. The prime contractor shall be responsible for compliance by any subcontractor, lower-tier subcontractor or service provider.
Form FHWA-1273 must be included in all Federal-aid design-build contracts, in all subcontracts and in lower tier subcontracts (excluding subcontracts for design services, purchase orders, rental agreements and other agreements for supplies or services). The design-builder shall be responsible for compliance by any subcontractor, lower-tier subcontractor or service provider.
Contracting agencies may reference Form FHWA-1273 in bid proposal or request for proposal documents, however, the Form FHWA-1273 must be physically incorporated (not referenced) in all contracts, subcontracts and lower-tier subcontracts (excluding purchase orders, rental agreements and other agreements for supplies or services related to a construction contract).
2. Subject to the applicability criteria noted in the following sections, these contract provisions shall apply to all work performed on the contract by the contractor's own organization and with the assistance of workers under the contractor's immediate superintendence and to all work performed on the contract by piecework, station work, or by subcontract.
3. A breach of any of the stipulations contained in these Required Contract Provisions may be sufficient grounds for withholding of progress payments, withholding of final payment, termination of the contract, suspension / debarment or any other action determined to be appropriate by the contracting agency and FHWA.
4. Selection of Labor: During the performance of this contract, the contractor shall not use convict labor for any purpose within the limits of a construction project on a Federal-aid highway unless it is labor performed by convicts who are on parole, supervised release, or probation. The term Federal-aid highway does not include roadways functionally classified as local roads or rural minor collectors.

II. NONDISCRIMINATION

The provisions of this section related to 23 CFR Part 230 are applicable to all Federal-aid construction contracts and to all related construction subcontracts of \$10,000 or more. The provisions of 23 CFR Part 230 are not applicable to material supply, engineering, or architectural service contracts.

In addition, the contractor and all subcontractors must comply with the following policies: Executive Order 11246, 41 CFR 60, 29 CFR 1625-1627, Title 23 USC Section 140, the Rehabilitation Act of 1973, as amended (29 USC 794), Title VI of the Civil Rights Act of 1964, as amended, and related regulations including 49 CFR Parts 21, 26 and 27; and 23 CFR Parts 200, 230, and 633.

The contractor and all subcontractors must comply with: the requirements of the Equal Opportunity Clause in 41 CFR 60-1.4(b) and, for all construction contracts exceeding \$10,000, the Standard Federal Equal Employment Opportunity Construction Contract Specifications in 41 CFR 60-4.3.

Note: The U.S. Department of Labor has exclusive authority to determine compliance with Executive Order 11246 and the policies of the Secretary of Labor including 41 CFR 60, and 29 CFR 1625-1627. The contracting agency and the FHWA have the authority and the responsibility to ensure compliance with Title 23 USC Section 140, the Rehabilitation Act of 1973, as amended (29 USC 794), and Title VI of the Civil Rights Act of 1964, as amended, and related regulations including 49 CFR Parts 21, 26 and 27; and 23 CFR Parts 200, 230, and 633.

The following provision is adopted from 23 CFR 230, Appendix A, with appropriate revisions to conform to the U.S. Department of Labor (US DOL) and FHWA requirements.

1. **Equal Employment Opportunity:** Equal employment opportunity (EEO) requirements not to discriminate and to take affirmative action to assure equal opportunity as set forth under laws, executive orders, rules, regulations (28 CFR 35, 29 CFR 1630, 29 CFR 1625-1627, 41 CFR 60 and 49 CFR 27) and orders of the Secretary of Labor as modified by the provisions prescribed herein, and imposed pursuant to 23 U.S.C. 140 shall constitute the EEO and specific affirmative action standards for the contractor's project activities under this contract. The provisions of the Americans with Disabilities Act of 1990 (42 U.S.C. 12101 et seq.) set forth under 28 CFR 35 and 29 CFR 1630 are incorporated by reference in this contract. In the execution of this contract, the contractor agrees to comply with the following minimum specific requirement activities of EEO:

- a. The contractor will work with the contracting agency and the Federal Government to ensure that it has made every good faith effort to provide equal opportunity with respect to all of its terms and conditions of employment and in their review of activities under the contract.
- b. The contractor will accept as its operating policy the following statement:
"It is the policy of this Company to assure that applicants are employed, and that employees are treated during employment, without regard to their race, religion, sex, color, national origin, age or disability. Such action shall include: employment, upgrading, demotion, or transfer; recruitment or recruitment advertising; layoff or termination; rates of pay or other forms of compensation; and selection for training, including apprenticeship, pre-apprenticeship, and/or on-the-job training."
2. **EEO Officer:** The contractor will designate and make known to the contracting officers an EEO Officer who will have the responsibility for and must be capable of effectively administering and promoting an active EEO program and who must be assigned adequate authority and responsibility to do so.
3. **Dissemination of Policy:** All members of the contractor's staff who are authorized to hire, supervise, promote, and discharge employees, or who recommend such action, or who are substantially involved in such action, will be made fully cognizant of, and will implement, the contractor's EEO policy and contractual responsibilities to provide EEO in each grade and classification of employment. To ensure that the above agreement will be met, the following actions will be taken as a minimum:
 - a. Periodic meetings of supervisory and personnel office employees will be conducted before the start of work and then not less often than once every six months, at which time the contractor's EEO policy and its implementation will be reviewed and explained. The meetings will be conducted by the EEO Officer.
 - b. All new supervisory or personnel office employees will be given a thorough indoctrination by the EEO Officer, covering all major aspects of the contractor's EEO obligations within thirty days following their reporting for duty with the contractor.
 - c. All personnel who are engaged in direct recruitment for the project will be instructed by the EEO Officer in the contractor's procedures for locating and hiring minorities and women.
 - d. Notices and posters setting forth the contractor's EEO policy will be placed in areas readily accessible to employees, applicants for employment and potential employees.
 - e. The contractor's EEO policy and the procedures to implement such policy will be brought to the attention of employees by means of meetings, employee handbooks, or other appropriate means.
4. **Recruitment:** When advertising for employees, the contractor will include in all advertisements for employees the notation: "An Equal Opportunity Employer." All such advertisements will be placed in publications having a large circulation among minorities and women in the area from which the project work force would normally be derived.
 - a. The contractor will, unless precluded by a valid bargaining agreement, conduct systematic and direct recruitment through public and private employee referral sources likely to yield qualified minorities and women. To meet this requirement, the contractor will identify sources of potential minority group employees, and establish with such identified sources procedures whereby minority and women applicants may be referred to the contractor for employment consideration.
 - b. In the event the contractor has a valid bargaining agreement providing for exclusive hiring hall referrals, the contractor is expected to observe the provisions of that agreement to the extent that the system meets the contractor's compliance with EEO contract provisions. Where implementation of such an agreement has the effect of discriminating against minorities or women, or obligates the contractor to do the same, such implementation violates Federal nondiscrimination provisions.
 - c. The contractor will encourage its present employees to refer minorities and women as applicants for employment. Information and procedures with regard to referring such applicants will be discussed with employees.
5. **Personnel Actions:** Wages, working conditions, and employee benefits shall be established and administered, and personnel actions of every type, including hiring, upgrading, promotion, transfer, demotion, layoff, and termination, shall be taken without regard to race, color, religion, sex, national origin, age or disability. The following procedures shall be followed:
 - a. The contractor will conduct periodic inspections of project sites to insure that working conditions and employee facilities do not indicate discriminatory treatment of project site personnel.
 - b. The contractor will periodically evaluate the spread of wages paid within each classification to determine any evidence of discriminatory wage practices.
 - c. The contractor will periodically review selected personnel actions in depth to determine whether there is evidence of discrimination. Where evidence is found, the contractor will promptly take corrective action. If the review indicates that the discrimination may extend beyond the actions reviewed, such corrective action shall include all affected persons.
 - d. The contractor will promptly investigate all complaints of alleged discrimination made to the contractor in connection with its obligations under this contract, will attempt to resolve such complaints, and will take appropriate corrective action within a reasonable time. If the investigation indicates that the discrimination may affect persons other than the complainant, such corrective action shall include such other persons. Upon completion of each investigation, the contractor will inform every complainant of all of their avenues of appeal.
6. **Training and Promotion:**
 - a. The contractor will assist in locating, qualifying, and increasing the skills of minorities and women who are applicants for employment or current employees. Such efforts should be aimed at developing full journey level status employees in the type of trade or job classification involved.
 - b. Consistent with the contractor's work force requirements and as permissible under Federal and State regulations, the contractor shall make full use of training programs, i.e., apprenticeship, and on-the-job training programs for the geographical area of contract performance. In the event a special provision for training is provided under this contract, this subparagraph will be superseded as indicated in the special provision. The contracting agency may reserve training positions for persons who receive welfare assistance in accordance with 23 U.S.C. 140(a).
 - c. The contractor will advise employees and applicants for employment of available training programs and entrance requirements for each.
 - d. The contractor will periodically review the training and promotion potential of employees who are minorities and women and will encourage eligible employees to apply for such training and promotion.

7. **Unions:** If the contractor relies in whole or in part upon unions as a source of employees, the contractor will use good faith efforts to obtain the cooperation of such unions to increase opportunities for minorities and women. Actions by the contractor, either directly or through a contractor's association acting as agent, will include the procedures set forth below:
 - a. The contractor will use good faith efforts to develop, in cooperation with the unions, joint training programs aimed toward qualifying more minorities and women for membership in the unions and increasing the skills of minorities and women so that they may qualify for higher paying employment.
 - b. The contractor will use good faith efforts to incorporate an EEO clause into each union agreement to the end that such union will be contractually bound to refer applicants without regard to their race, color, religion, sex, national origin, age or disability.
 - c. The contractor is to obtain information as to the referral practices and policies of the labor union except that to the extent such information is within the exclusive possession of the labor union and such labor union refuses to furnish such information to the contractor, the contractor shall so certify to the contracting agency and shall set forth what efforts have been made to obtain such information.
 - d. In the event the union is unable to provide the contractor with a reasonable flow of referrals within the time limit set forth in the collective bargaining agreement, the contractor will, through independent recruitment efforts, fill the employment vacancies without regard to race, color, religion, sex, national origin, age or disability; making full efforts to obtain qualified and/or qualifiable minorities and women. The failure of a union to provide sufficient referrals (even though it is obligated to provide exclusive referrals under the terms of a collective bargaining agreement) does not relieve the contractor from the requirements of this paragraph. In the event the union referral practice prevents the contractor from meeting the obligations pursuant to Executive Order 11246, as amended, and these special provisions, such contractor shall immediately notify the contracting agency.
8. **Reasonable Accommodation for Applicants / Employees with Disabilities:** The contractor must be familiar with the requirements for and comply with the Americans with Disabilities Act and all rules and regulations established there under. Employers must provide reasonable accommodation in all employment activities unless to do so would cause an undue hardship.
9. **Selection of Subcontractors, Procurement of Materials and Leasing of Equipment:** The contractor shall not discriminate on the grounds of race, color, religion, sex, national origin, age or disability in the selection and retention of subcontractors, including procurement of materials and leases of equipment. The contractor shall take all necessary and reasonable steps to ensure nondiscrimination in the administration of this contract.
 - a. The contractor shall notify all potential subcontractors and suppliers and lessors of their EEO obligations under this contract.
 - b. The contractor will use good faith efforts to ensure subcontractor compliance with their EEO obligations.
10. **Assurance Required by 49 CFR 26.13(b):**
 - a. The requirements of 49 CFR Part 26 and the State DOT's U.S. DOT-approved DBE program are incorporated by reference.
 - b. The contractor or subcontractor shall not discriminate on the basis of race, color, national origin, or sex in the performance of this contract. The contractor shall carry out applicable requirements of 49 CFR Part 26 in the award and administration of DOT-assisted contracts. Failure by the contractor to carry out these requirements is a material breach of this contract, which may result in the termination of this contract or such other remedy as the contracting agency deems appropriate.
11. **Records and Reports:** The contractor shall keep such records as necessary to document compliance with the EEO requirements. Such records shall be retained for a period of three years following the date of the final payment to the contractor for all contract work and shall be available at reasonable times and places for inspection by authorized representatives of the contracting agency and the FHWA.
 - a. The records kept by the contractor shall document the following:
 - (1) The number and work hours of minority and non-minority group members and women employed in each work classification on the project;
 - (2) The progress and efforts being made in cooperation with unions, when applicable, to increase employment opportunities for minorities and women; and
 - (3) The progress and efforts being made in locating, hiring, training, qualifying, and upgrading minorities and women;
 - b. The contractors and subcontractors will submit an annual report to the contracting agency each July for the duration of the project, indicating the number of minority, women, and non-minority group employees currently engaged in each work classification required by the contract work. This information is to be reported on Form FHWA-1391. The staffing data should represent the project work force on board in all or any part of the last payroll period preceding the end of July. If on-the-job training is being required by special provision, the contractor will be required to collect and report training data. The employment data should reflect the work force on board during all or any part of the last payroll period preceding the end of July.

III. NONSEGREGATED FACILITIES

This provision is applicable to all Federal-aid construction contracts and to all related construction subcontracts of \$10,000 or more.

The contractor must ensure that facilities provided for employees are provided in such a manner that segregation on the basis of race, color, religion, sex, or national origin cannot result. The contractor may neither require such segregated use by written or oral policies nor tolerate such use by employee custom. The contractor's obligation extends further to ensure that its employees are not assigned to perform their services at any location, under the contractor's control, where the facilities are segregated. The term "facilities" includes waiting rooms, work areas, restaurants and other eating areas, time clocks, restrooms, washrooms, locker rooms, and other storage or dressing areas, parking lots, drinking fountains, recreation or entertainment areas, transportation, and housing provided for employees. The contractor shall provide separate or single-user restrooms and necessary dressing or sleeping areas to assure privacy between sexes.

IV. DAVIS-BACON AND RELATED ACT PROVISIONS

This section is applicable to all Federal-aid construction projects exceeding \$2,000 and to all related subcontracts and lower-tier subcontracts (regardless of subcontract size). The requirements apply to all projects located within the right-of-way of a roadway that is functionally classified as Federal-aid highway. This excludes roadways functionally classified as local roads or rural minor collectors, which are exempt. Contracting agencies may elect to apply these requirements to other projects.

The following provisions are from the U.S. Department of Labor regulations in 29 CFR 5.5 "Contract provisions and related matters" with minor revisions to conform to the FHWA-1273 format and FHWA program requirements.

1. Minimum wages

- a. All laborers and mechanics employed or working upon the site of the work, will be paid unconditionally and not less often than once a week, and without subsequent deduction or rebate on any account (except such payroll deductions as are permitted by regulations issued by the Secretary of Labor under the Copeland Act (29 CFR part 3)), the full amount of wages and bona fide fringe benefits (or cash equivalents

thereof) due at time of payment computed at rates not less than those contained in the wage determination of the Secretary of Labor which is attached hereto and made a part hereof, regardless of any contractual relationship which may be alleged to exist between the contractor and such laborers and mechanics.

Contributions made or costs reasonably anticipated for bona fide fringe benefits under section 1(b)(2) of the Davis-Bacon Act on behalf of laborers or mechanics are considered wages paid to such laborers or mechanics, subject to the provisions of paragraph 1.d. of this section; also, regular contributions made or costs incurred for more than a weekly period (but not less often than quarterly) under plans, funds, or programs which cover the particular weekly period, are deemed to be constructively made or incurred during such weekly period. Such laborers and mechanics shall be paid the appropriate wage rate and fringe benefits on the wage determination for the classification of work actually performed, without regard to skill, except as provided in 29 CFR 5.5(a)(4). Laborers or mechanics performing work in more than one classification may be compensated at the rate specified for each classification for the time actually worked therein: Provided, That the employer's payroll records accurately set forth the time spent in each classification in which work is performed. The wage determination (including any additional classification and wage rates conformed under paragraph 1.b. of this section) and the Davis-Bacon poster (WH-1321) shall be posted at all times by the contractor and its subcontractors at the site of the work in a prominent and accessible place where it can be easily seen by the workers.

- b. (1) The contracting officer shall require that any class of laborers or mechanics, including helpers, which is not listed in the wage determination and which is to be employed under the contract shall be classified in conformance with the wage determination. The contracting officer shall approve an additional classification and wage rate and fringe benefits therefore only when the following criteria have been met:
 - (i) The work to be performed by the classification requested is not performed by a classification in the wage determination; and
 - (ii) The classification is utilized in the area by the construction industry; and
 - (iii) The proposed wage rate, including any bona fide fringe benefits, bears a reasonable relationship to the wage rates contained in the wage determination.
 - (2) If the contractor and the laborers and mechanics to be employed in the classification (if known), or their representatives, and the contracting officer agree on the classification and wage rate (including the amount designated for fringe benefits where appropriate), a report of the action taken shall be sent by the contracting officer to the Administrator of the Wage and Hour Division, Employment Standards Administration, U.S. Department of Labor, Washington, DC 20210. The Administrator, or an authorized representative, will approve, modify, or disapprove every additional classification action within 30 days of receipt and so advise the contracting officer or will notify the contracting officer within the 30-day period that additional time is necessary.
 - (3) In the event the contractor, the laborers or mechanics to be employed in the classification or their representatives, and the contracting officer do not agree on the proposed classification and wage rate (including the amount designated for fringe benefits, where appropriate), the contracting officer shall refer the questions, including the views of all interested parties and the recommendation of the contracting officer, to the Wage and Hour Administrator for determination. The Wage and Hour Administrator, or an authorized representative, will issue a determination within 30 days of receipt and so advise the contracting officer or will notify the contracting officer within the 30-day period that additional time is necessary.
 - (4) The wage rate (including fringe benefits where appropriate) determined pursuant to paragraphs 1.b.(2) or 1.b.(3) of this section, shall be paid to all workers performing work in the classification under this contract from the first day on which work is performed in the classification.
- c. Whenever the minimum wage rate prescribed in the contract for a class of laborers or mechanics includes a fringe benefit which is not expressed as an hourly rate, the contractor shall either pay the benefit as stated in the wage determination or shall pay another bona fide fringe benefit or an hourly cash equivalent thereof.
 - d. If the contractor does not make payments to a trustee or other third person, the contractor may consider as part of the wages of any laborer or mechanic the amount of any costs reasonably anticipated in providing bona fide fringe benefits under a plan or program, Provided, That the Secretary of Labor has found, upon the written request of the contractor, that the applicable standards of the Davis-Bacon Act have been met. The Secretary of Labor may require the contractor to set aside in a separate account assets for the meeting of obligations under the plan or program.
2. **Withholding.** The contracting agency shall upon its own action or upon written request of an authorized representative of the Department of Labor, withhold or cause to be withheld from the contractor under this contract, or any other Federal contract with the same prime contractor, or any other federally-assisted contract subject to Davis-Bacon prevailing wage requirements, which is held by the same prime contractor, so much of the accrued payments or advances as may be considered necessary to pay laborers and mechanics, including apprentices, trainees, and helpers, employed by the contractor or any subcontractor the full amount of wages required by the contract. In the event of failure to pay any laborer or mechanic, including any apprentice, trainee, or helper, employed or working on the site of the work, all or part of the wages required by the contract, the contracting agency may, after written notice to the contractor, take such action as may be necessary to cause the suspension of any further payment, advance, or guarantee of funds until such violations have ceased.
 3. **Payrolls and basic records**
 - a. Payrolls and basic records relating thereto shall be maintained by the contractor during the course of the work and preserved for a period of three years thereafter for all laborers and mechanics working at the site of the work. Such records shall contain the name, address, and social security number of each such worker, his or her correct classification, hourly rates of wages paid (including rates of contributions or costs anticipated for bona fide fringe benefits or cash equivalents thereof of the types described in section 1(b)(2)(B) of the Davis-Bacon Act), daily and weekly number of hours worked, deductions made and actual wages paid. Whenever the Secretary of Labor has found under 29 CFR 5.5(a)(1)(iv) that the wages of any laborer or mechanic include the amount of any costs reasonably anticipated in providing benefits under a plan or program described in section 1(b)(2)(B) of the Davis-Bacon Act, the contractor shall maintain records which show that the commitment to provide such benefits is enforceable, that the plan or program is financially responsible, and that the plan or program has been communicated in writing to the laborers or mechanics affected, and records which show the costs anticipated or the actual cost incurred in providing such benefits. Contractors employing apprentices or trainees under approved programs shall maintain written evidence of the registration of apprenticeship programs and certification of trainee programs, the registration of the apprentices and trainees, and the ratios and wage rates prescribed in the applicable programs.
 - b. (1) The contractor shall submit weekly for each week in which any contract work is performed a copy of all payrolls to the contracting agency. The payrolls submitted shall set out accurately and completely all of the information required to be maintained under 29 CFR 5.5(a)(3)(i), except that full social security numbers and home addresses shall not be included on weekly transmittals. Instead the payrolls shall only need to include an individually identifying number for each employee (e.g. , the last four digits of the employee's social security number). The required weekly payroll information may be submitted in any form desired. Optional Form WH-347 is available for

this purpose from the Wage and Hour Division Web site at <http://www.dol.gov/esa/whd/forms/wh347instr.htm> or its successor site. The prime contractor is responsible for the submission of copies of payrolls by all subcontractors. Contractors and subcontractors shall maintain the full social security number and current address of each covered worker, and shall provide them upon request to the contracting agency for transmission to the State DOT, the FHWA or the Wage and Hour Division of the Department of Labor for purposes of an investigation or audit of compliance with prevailing wage requirements. It is not a violation of this section for a prime contractor to require a subcontractor to provide addresses and social security numbers to the prime contractor for its own records, without weekly submission to the contracting agency.

- (2) Each payroll submitted shall be accompanied by a "Statement of Compliance," signed by the contractor or subcontractor or his or her agent who pays or supervises the payment of the persons employed under the contract and shall certify the following:
 - (i) That the payroll for the payroll period contains the information required to be provided under §5.5 (a)(3)(ii) of Regulations, 29 CFR part 5, the appropriate information is being maintained under §5.5 (a)(3)(i) of Regulations, 29 CFR part 5, and that such information is correct and complete;
 - (ii) That each laborer or mechanic (including each helper, apprentice, and trainee) employed on the contract during the payroll period has been paid the full weekly wages earned, without rebate, either directly or indirectly, and that no deductions have been made either directly or indirectly from the full wages earned, other than permissible deductions as set forth in Regulations, 29 CFR part 3;
 - (iii) That each laborer or mechanic has been paid not less than the applicable wage rates and fringe benefits or cash equivalents for the classification of work performed, as specified in the applicable wage determination incorporated into the contract.
 - (3) The weekly submission of a properly executed certification set forth on the reverse side of Optional Form WH-347 shall satisfy the requirement for submission of the "Statement of Compliance" required by paragraph 3.b.(2) of this section.
 - (4) The falsification of any of the above certifications may subject the contractor or subcontractor to civil or criminal prosecution under section 1001 of title 18 and section 231 of title 31 of the United States Code.
- c. The contractor or subcontractor shall make the records required under paragraph 3.a. of this section available for inspection, copying, or transcription by authorized representatives of the contracting agency, the State DOT, the FHWA, or the Department of Labor, and shall permit such representatives to interview employees during working hours on the job. If the contractor or subcontractor fails to submit the required records or to make them available, the FHWA may, after written notice to the contractor, the contracting agency or the State DOT, take such action as may be necessary to cause the suspension of any further payment, advance, or guarantee of funds. Furthermore, failure to submit the required records upon request or to make such records available may be grounds for debarment action pursuant to 29 CFR 5.12.

4. Apprentices and trainees

- a. Apprentices (programs of the USDOL). Apprentices will be permitted to work at less than the predetermined rate for the work they performed when they are employed pursuant to and individually registered in a bona fide apprenticeship program registered with the U.S. Department of Labor, Employment and Training Administration, Office of Apprenticeship Training, Employer and Labor Services, or with a State Apprenticeship Agency recognized by the Office, or if a person is employed in his or her first 90 days of probationary employment as an apprentice in such an apprenticeship program, who is not individually registered in the program, but who has been certified by the Office of Apprenticeship Training, Employer and Labor Services or a State Apprenticeship Agency (where appropriate) to be eligible for probationary employment as an apprentice.

The allowable ratio of apprentices to journeymen on the job site in any craft classification shall not be greater than the ratio permitted to the contractor as to the entire work force under the registered program. Any worker listed on a payroll at an apprentice wage rate, who is not registered or otherwise employed as stated above, shall be paid not less than the applicable wage rate on the wage determination for the classification of work actually performed. In addition, any apprentice performing work on the job site in excess of the ratio permitted under the registered program shall be paid not less than the applicable wage rate on the wage determination for the work actually performed. Where a contractor is performing construction on a project in a locality other than that in which its program is registered, the ratios and wage rates (expressed in percentages of the journeyman's hourly rate) specified in the contractor's or subcontractor's registered program shall be observed.

Every apprentice must be paid at not less than the rate specified in the registered program for the apprentice's level of progress, expressed as a percentage of the journeymen hourly rate specified in the applicable wage determination. Apprentices shall be paid fringe benefits in accordance with the provisions of the apprenticeship program. If the apprenticeship program does not specify fringe benefits, apprentices must be paid the full amount of fringe benefits listed on the wage determination for the applicable classification. If the Administrator determines that a different practice prevails for the applicable apprentice classification, fringes shall be paid in accordance with that determination.

In the event the Office of Apprenticeship Training, Employer and Labor Services, or a State Apprenticeship Agency recognized by the Office, withdraws approval of an apprenticeship program, the contractor will no longer be permitted to utilize apprentices at less than the applicable predetermined rate for the work performed until an acceptable program is approved.

- b. Trainees (programs of the USDOL). Except as provided in 29 CFR 5.16, trainees will not be permitted to work at less than the predetermined rate for the work performed unless they are employed pursuant to and individually registered in a program which has received prior approval, evidenced by formal certification by the U.S. Department of Labor, Employment and Training Administration.

The ratio of trainees to journeymen on the job site shall not be greater than permitted under the plan approved by the Employment and Training Administration.

Every trainee must be paid at not less than the rate specified in the approved program for the trainee's level of progress, expressed as a percentage of the journeyman hourly rate specified in the applicable wage determination. Trainees shall be paid fringe benefits in accordance with the provisions of the trainee program. If the trainee program does not mention fringe benefits, trainees shall be paid the full amount of fringe benefits listed on the wage determination unless the Administrator of the Wage and Hour Division determines that there is an apprenticeship program associated with the corresponding journeyman wage rate on the wage determination which provides for less than full fringe benefits for apprentices. Any employee listed on the payroll at a trainee rate who is not registered and participating in a training plan approved by the Employment and Training Administration shall be paid not less than the applicable wage rate on the wage determination for the classification of work actually performed. In addition, any trainee performing work on the job site in excess of the ratio permitted under the registered program shall be paid not less than the applicable wage rate on the wage determination for the work actually performed.

In the event the Employment and Training Administration withdraws approval of a training program, the contractor will no longer be permitted to utilize trainees at less than the applicable predetermined rate for the work performed until an acceptable program is approved.

- c. Equal employment opportunity. The utilization of apprentices, trainees and journeymen under this part shall be in conformity with the equal employment opportunity requirements of Executive Order 11246, as amended, and 29 CFR part 30.
- d. Apprentices and Trainees (programs of the U.S. DOT). Apprentices and trainees working under apprenticeship and skill training programs which have been certified by the Secretary of Transportation as promoting EEO in connection with Federal-aid highway construction programs

are not subject to the requirements of paragraph 4 of this Section IV. The straight time hourly wage rates for apprentices and trainees under such programs will be established by the particular programs. The ratio of apprentices and trainees to journeymen shall not be greater than permitted by the terms of the particular program.

5. **Compliance with Copeland Act requirements.** The contractor shall comply with the requirements of 29 CFR part 3, which are incorporated by reference in this contract.
6. **Subcontracts.** The contractor or subcontractor shall insert Form FHWA-1273 in any subcontracts and also require the subcontractors to include Form FHWA-1273 in any lower tier subcontracts. The prime contractor shall be responsible for the compliance by any subcontractor or lower tier subcontractor with all the contract clauses in 29 CFR 5.5.
7. **Contract termination:** debarment. A breach of the contract clauses in 29 CFR 5.5 may be grounds for termination of the contract, and for debarment as a contractor and a subcontractor as provided in 29 CFR 5.12.
8. **Compliance with Davis-Bacon and Related Act requirements.** All rulings and interpretations of the Davis-Bacon and Related Acts contained in 29 CFR parts 1, 3, and 5 are herein incorporated by reference in this contract.
9. **Disputes concerning labor standards.** Disputes arising out of the labor standards provisions of this contract shall not be subject to the general disputes clause of this contract. Such disputes shall be resolved in accordance with the procedures of the Department of Labor set forth in 29 CFR parts 5, 6, and 7. Disputes within the meaning of this clause include disputes between the contractor (or any of its subcontractors) and the contracting agency, the U.S. Department of Labor, or the employees or their representatives.
10. **Certification of eligibility.**
 - a. By entering into this contract, the contractor certifies that neither it (nor he or she) nor any person or firm who has an interest in the contractor's firm is a person or firm ineligible to be awarded Government contracts by virtue of section 3(a) of the Davis-Bacon Act or 29 CFR 5.12(a)(1).
 - b. No part of this contract shall be subcontracted to any person or firm ineligible for award of a Government contract by virtue of section 3(a) of the Davis-Bacon Act or 29 CFR 5.12(a)(1).
 - c. The penalty for making false statements is prescribed in the U.S. Criminal Code, 18 U.S.C. 1001.

V. CONTRACT WORK HOURS AND SAFETY STANDARDS ACT

The following clauses apply to any Federal-aid construction contract in an amount in excess of \$100,000 and subject to the overtime provisions of the Contract Work Hours and Safety Standards Act. These clauses shall be inserted in addition to the clauses required by 29 CFR 5.5(a) or 29 CFR 4.6. As used in this paragraph, the terms laborers and mechanics include watchmen and guards.

1. **Overtime requirements.** No contractor or subcontractor contracting for any part of the contract work which may require or involve the employment of laborers or mechanics shall require or permit any such laborer or mechanic in any workweek in which he or she is employed on such work to work in excess of forty hours in such workweek unless such laborer or mechanic receives compensation at a rate not less than one and one-half times the basic rate of pay for all hours worked in excess of forty hours in such workweek.
2. **Violation; liability for unpaid wages; liquidated damages.** In the event of any violation of the clause set forth in paragraph (1.) of this section, the contractor and any subcontractor responsible therefor shall be liable for the unpaid wages. In addition, such contractor and subcontractor shall be liable to the United States (in the case of work done under contract for the District of Columbia or a territory, to such District or to such territory), for liquidated damages. Such liquidated damages shall be computed with respect to each individual laborer or mechanic, including watchmen and guards, employed in violation of the clause set forth in paragraph (1.) of this section, in the sum of \$10 for each calendar day on which such individual was required or permitted to work in excess of the standard workweek of forty hours without payment of the overtime wages required by the clause set forth in paragraph (1.) of this section.
3. **Withholding for unpaid wages and liquidated damages.** The FHWA or the contracting agency shall upon its own action or upon written request of an authorized representative of the Department of Labor withhold or cause to be withheld, from any moneys payable on account of work performed by the contractor or subcontractor under any such contract or any other Federal contract with the same prime contractor, or any other federally-assisted contract subject to the Contract Work Hours and Safety Standards Act, which is held by the same prime contractor, such sums as may be determined to be necessary to satisfy any liabilities of such contractor or subcontractor for unpaid wages and liquidated damages as provided in the clause set forth in paragraph (2.) of this section.
4. **Subcontracts.** The contractor or subcontractor shall insert in any subcontracts the clauses set forth in paragraph (1.) through (4.) of this section and also a clause requiring the subcontractors to include these clauses in any lower tier subcontracts. The prime contractor shall be responsible for compliance by any subcontractor or lower tier subcontractor with the clauses set forth in paragraphs (1.) through (4.) of this section.

VI. SUBLETTING OR ASSIGNING THE CONTRACT

This provision is applicable to all Federal-aid construction contracts on the National Highway System.

1. The contractor shall perform with its own organization contract work amounting to not less than 30 percent (or a greater percentage if specified elsewhere in the contract) of the total original contract price, excluding any specialty items designated by the contracting agency. Specialty items may be performed by subcontract and the amount of any such specialty items performed may be deducted from the total original contract price before computing the amount of work required to be performed by the contractor's own organization (23 CFR 635.116).
 - a. The term "perform work with its own organization" refers to workers employed or leased by the prime contractor, and equipment owned or rented by the prime contractor, with or without operators. Such term does not include employees or equipment of a subcontractor or lower tier subcontractor, agents of the prime contractor, or any other assignees. The term may include payments for the costs of hiring leased employees from an employee leasing firm meeting all relevant Federal and State regulatory requirements. Leased employees may only be included in this term if the prime contractor meets all of the following conditions:
 - (1) the prime contractor maintains control over the supervision of the day-to-day activities of the leased employees;
 - (2) the prime contractor remains responsible for the quality of the work of the leased employees;
 - (3) the prime contractor retains all power to accept or exclude individual employees from work on the project; and
 - (4) the prime contractor remains ultimately responsible for the payment of predetermined minimum wages, the submission of payrolls, statements of compliance and all other Federal regulatory requirements.
 - b. "Specialty Items" shall be construed to be limited to work that requires highly specialized knowledge, abilities, or equipment not ordinarily available in the type of contracting organizations qualified and expected to bid or propose on the contract as a whole and in general are to be limited to minor components of the overall contract.

2. The contract amount upon which the requirements set forth in paragraph (1) of Section VI is computed includes the cost of material and manufactured products which are to be purchased or produced by the contractor under the contract provisions.
3. The contractor shall furnish (a) a competent superintendent or supervisor who is employed by the firm, has full authority to direct performance of the work in accordance with the contract requirements, and is in charge of all construction operations (regardless of who performs the work) and (b) such other of its own organizational resources (supervision, management, and engineering services) as the contracting officer determines is necessary to assure the performance of the contract.
4. No portion of the contract shall be sublet, assigned or otherwise disposed of except with the written consent of the contracting officer, or authorized representative, and such consent when given shall not be construed to relieve the contractor of any responsibility for the fulfillment of the contract. Written consent will be given only after the contracting agency has assured that each subcontract is evidenced in writing and that it contains all pertinent provisions and requirements of the prime contract.
5. The 30% self-performance requirement of paragraph (1) is not applicable to design-build contracts; however, contracting agencies may establish their own self-performance requirements.

VII. SAFETY: ACCIDENT PREVENTION

This provision is applicable to all Federal-aid construction contracts and to all related subcontracts.

1. In the performance of this contract the contractor shall comply with all applicable Federal, State, and local laws governing safety, health, and sanitation (23 CFR 635). The contractor shall provide all safeguards, safety devices and protective equipment and take any other needed actions as it determines, or as the contracting officer may determine, to be reasonably necessary to protect the life and health of employees on the job and the safety of the public and to protect property in connection with the performance of the work covered by the contract.
2. It is a condition of this contract, and shall be made a condition of each subcontract, which the contractor enters into pursuant to this contract, that the contractor and any subcontractor shall not permit any employee, in performance of the contract, to work in surroundings or under conditions which are unsanitary, hazardous or dangerous to his/her health or safety, as determined under construction safety and health standards (29 CFR 1926) promulgated by the Secretary of Labor, in accordance with Section 107 of the Contract Work Hours and Safety Standards Act (40 U.S.C. 3704).
3. Pursuant to 29 CFR 1926.3, it is a condition of this contract that the Secretary of Labor or authorized representative thereof, shall have right of entry to any site of contract performance to inspect or investigate the matter of compliance with the construction safety and health standards and to carry out the duties of the Secretary under Section 107 of the Contract Work Hours and Safety Standards Act (40 U.S.C.3704).

VIII. FALSE STATEMENTS CONCERNING HIGHWAY PROJECTS

This provision is applicable to all Federal-aid construction contracts and to all related subcontracts.

In order to assure high quality and durable construction in conformity with approved plans and specifications and a high degree of reliability on statements and representations made by engineers, contractors, suppliers, and workers on Federal-aid highway projects, it is essential that all persons concerned with the project perform their functions as carefully, thoroughly, and honestly as possible. Willful falsification, distortion, or misrepresentation with respect to any facts related to the project is a violation of Federal law. To prevent any misunderstanding regarding the seriousness of these and similar acts, Form FHWA-1022 shall be posted on each Federal-aid highway project (23 CFR 635) in one or more places where it is readily available to all persons concerned with the project:

18 U.S.C. 1020 reads as follows:

"Whoever, being an officer, agent, or employee of the United States, or of any State or Territory, or whoever, whether a person, association, firm, or corporation, knowingly makes any false statement, false representation, or false report as to the character, quality, quantity, or cost of the material used or to be used, or the quantity or quality of the work performed or to be performed, or the cost thereof in connection with the submission of plans, maps, specifications, contracts, or costs of construction on any highway or related project submitted for approval to the Secretary of Transportation; or

Whoever knowingly makes any false statement, false representation, false report or false claim with respect to the character, quality, quantity, or cost of any work performed or to be performed, or materials furnished or to be furnished, in connection with the construction of any highway or related project approved by the Secretary of Transportation; or

Whoever knowingly makes any false statement or false representation as to material fact in any statement, certificate, or report submitted pursuant to provisions of the Federal-aid Roads Act approved July 1, 1916, (39 Stat. 355), as amended and supplemented;

Shall be fined under this title or imprisoned not more than 5 years or both."

IX. IMPLEMENTATION OF CLEAN AIR ACT AND FEDERAL WATER POLLUTION CONTROL ACT

This provision is applicable to all Federal-aid construction contracts and to all related subcontracts.

By submission of this bid/proposal or the execution of this contract, or subcontract, as appropriate, the bidder, proposer, Federal-aid construction contractor, or subcontractor, as appropriate, will be deemed to have stipulated as follows:

1. That any person who is or will be utilized in the performance of this contract is not prohibited from receiving an award due to a violation of Section 508 of the Clean Water Act or Section 306 of the Clean Air Act.
2. That the contractor agrees to include or cause to be included the requirements of paragraph (1) of this Section X in every subcontract, and further agrees to take such action as the contracting agency may direct as a means of enforcing such requirements.

X. CERTIFICATION REGARDING DEBARMENT, SUSPENSION, INELIGIBILITY AND VOLUNTARY EXCLUSION

This provision is applicable to all Federal-aid construction contracts, design-build contracts, subcontracts, lower-tier subcontracts, purchase orders, lease agreements, consultant contracts or any other covered transaction requiring FHWA approval or that is estimated to cost \$25,000 or more – as defined in 2 CFR Parts 180 and 1200.

1. Instructions for Certification – First Tier Participants:

- a. By signing and submitting this proposal, the prospective first tier participant is providing the certification set out below.
- b. The inability of a person to provide the certification set out below will not necessarily result in denial of participation in this covered transaction. The prospective first tier participant shall submit an explanation of why it cannot provide the certification set out below. The certification or explanation will be considered in connection with the department or agency's determination whether to enter into this transaction. However,

failure of the prospective first tier participant to furnish a certification or an explanation shall disqualify such a person from participation in this transaction.

- c. The certification in this clause is a material representation of fact upon which reliance was placed when the contracting agency determined to enter into this transaction. If it is later determined that the prospective participant knowingly rendered an erroneous certification, in addition to other remedies available to the Federal Government, the contracting agency may terminate this transaction for cause of default.
- d. The prospective first tier participant shall provide immediate written notice to the contracting agency to whom this proposal is submitted if any time the prospective first tier participant learns that its certification was erroneous when submitted or has become erroneous by reason of changed circumstances.
- e. The terms "covered transaction," "debarred," "suspended," "ineligible," "participant," "person," "principal," and "voluntarily excluded," as used in this clause, are defined in 2 CFR Parts 180 and 1200. "First Tier Covered Transactions" refers to any covered transaction between a grantee or subgrantee of Federal funds and a participant (such as the prime or general contract). "Lower Tier Covered Transactions" refers to any covered transaction under a First Tier Covered Transaction (such as subcontracts). "First Tier Participant" refers to the participant who has entered into a covered transaction with a grantee or subgrantee of Federal funds (such as the prime or general contractor). "Lower Tier Participant" refers any participant who has entered into a covered transaction with a First Tier Participant or other Lower Tier Participants (such as subcontractors and suppliers).
- f. The prospective first tier participant agrees by submitting this proposal that, should the proposed covered transaction be entered into, it shall not knowingly enter into any lower tier covered transaction with a person who is debarred, suspended, declared ineligible, or voluntarily excluded from participation in this covered transaction, unless authorized by the department or agency entering into this transaction.
- g. The prospective first tier participant further agrees by submitting this proposal that it will include the clause titled "Certification Regarding Debarment, Suspension, Ineligibility and Voluntary Exclusion-Lower Tier Covered Transactions," provided by the department or contracting agency, entering into this covered transaction, without modification, in all lower tier covered transactions and in all solicitations for lower tier covered transactions exceeding the \$25,000 threshold.
- h. A participant in a covered transaction may rely upon a certification of a prospective participant in a lower tier covered transaction that is not debarred, suspended, ineligible, or voluntarily excluded from the covered transaction, unless it knows that the certification is erroneous. A participant is responsible for ensuring that its principals are not suspended, debarred, or otherwise ineligible to participate in covered transactions. To verify the eligibility of its principals, as well as the eligibility of any lower tier prospective participants, each participant may, but is not required to, check the Excluded Parties List System website (<https://www.epls.gov/>), which is compiled by the General Services Administration.
- i. Nothing contained in the foregoing shall be construed to require the establishment of a system of records in order to render in good faith the certification required by this clause. The knowledge and information of the prospective participant is not required to exceed that which is normally possessed by a prudent person in the ordinary course of business dealings.
- j. Except for transactions authorized under paragraph (f) of these instructions, if a participant in a covered transaction knowingly enters into a lower tier covered transaction with a person who is suspended, debarred, ineligible, or voluntarily excluded from participation in this transaction, in addition to other remedies available to the Federal Government, the department or agency may terminate this transaction for cause or default.

* * * * *

2. **Certification Regarding Debarment, Suspension, Ineligibility and Voluntary Exclusion – First Tier Participants:**

- a. The prospective first tier participant certifies to the best of its knowledge and belief, that it and its principals:
 - (1) Are not presently debarred, suspended, proposed for debarment, declared ineligible, or voluntarily excluded from participating in covered transactions by any Federal department or agency;
 - (2) Have not within a three-year period preceding this proposal been convicted of or had a civil judgment rendered against them for commission of fraud or a criminal offense in connection with obtaining, attempting to obtain, or performing a public (Federal, State or local) transaction or contract under a public transaction; violation of Federal or State antitrust statutes or commission of embezzlement, theft, forgery, bribery, falsification or destruction of records, making false statements, or receiving stolen property;
 - (3) Are not presently indicted for or otherwise criminally or civilly charged by a governmental entity (Federal, State or local) with commission of any of the offenses enumerated in paragraph (a)(2) of this certification; and
 - (4) Have not within a three-year period preceding this application/proposal had one or more public transactions (Federal, State or local) terminated for cause or default.
- b. Where the prospective participant is unable to certify to any of the statements in this certification, such prospective participant shall attach an explanation to this proposal.

2. **Instructions for Certification - Lower Tier Participants:**

(Applicable to all subcontracts, purchase orders and other lower tier transactions requiring prior FHWA approval or estimated to cost \$25,000 or more - 2 CFR Parts 180 and 1200)

- a. By signing and submitting this proposal, the prospective lower tier is providing the certification set out below.
- b. The certification in this clause is a material representation of fact upon which reliance was placed when this transaction was entered into. If it is later determined that the prospective lower tier participant knowingly rendered an erroneous certification, in addition to other remedies available to the Federal Government, the department, or agency with which this transaction originated may pursue available remedies, including suspension and/or debarment.
- c. The prospective lower tier participant shall provide immediate written notice to the person to which this proposal is submitted if at any time the prospective lower tier participant learns that its certification was erroneous by reason of changed circumstances.
- d. The terms "covered transaction," "debarred," "suspended," "ineligible," "participant," "person," "principal," and "voluntarily excluded," as used in this clause, are defined in 2 CFR Parts 180 and 1200. You may contact the person to which this proposal is submitted for assistance in obtaining a copy of those regulations. "First Tier Covered Transactions" refers to any covered transaction between a grantee or subgrantee of Federal funds and a participant (such as the prime or general contract). "Lower Tier Covered Transactions" refers to any covered transaction under a First Tier Covered Transaction (such as subcontracts). "First Tier Participant" refers to the participant who has entered into a covered transaction with a grantee or subgrantee of Federal funds (such as the prime or general contractor). "Lower Tier Participant" refers any participant who has entered into a covered transaction with a First Tier Participant or other Lower Tier Participants (such as subcontractors and suppliers).

- e. The prospective lower tier participant agrees by submitting this proposal that, should the proposed covered transaction be entered into, it shall not knowingly enter into any lower tier covered transaction with a person who is debarred, suspended, declared ineligible, or voluntarily excluded from participation in this covered transaction, unless authorized by the department or agency with which this transaction originated.
- f. The prospective lower tier participant further agrees by submitting this proposal that it will include this clause titled "Certification Regarding Debarment, Suspension, Ineligibility and Voluntary Exclusion-Lower Tier Covered Transaction," without modification, in all lower tier covered transactions and in all solicitations for lower tier covered transactions exceeding the \$25,000 threshold.
- g. A participant in a covered transaction may rely upon a certification of a prospective participant in a lower tier covered transaction that is not debarred, suspended, ineligible, or voluntarily excluded from the covered transaction, unless it knows that the certification is erroneous. A participant is responsible for ensuring that its principals are not suspended, debarred, or otherwise ineligible to participate in covered transactions. To verify the eligibility of its principals, as well as the eligibility of any lower tier prospective participants, each participant may, but is not required to, check the Excluded Parties List System website (<https://www.epls.gov/>), which is compiled by the General Services Administration.
- h. Nothing contained in the foregoing shall be construed to require establishment of a system of records in order to render in good faith the certification required by this clause. The knowledge and information of participant is not required to exceed that which is normally possessed by a prudent person in the ordinary course of business dealings.
- i. Except for transactions authorized under paragraph e of these instructions, if a participant in a covered transaction knowingly enters into a lower tier covered transaction with a person who is suspended, debarred, ineligible, or voluntarily excluded from participation in this transaction, in addition to other remedies available to the Federal Government, the department or agency with which this transaction originated may pursue available remedies, including suspension and/or debarment.

* * * * *

Certification Regarding Debarment, Suspension, Ineligibility and Voluntary Exclusion--Lower Tier Participants:

1. The prospective lower tier participant certifies, by submission of this proposal, that neither it nor its principals is presently debarred, suspended, proposed for debarment, declared ineligible, or voluntarily excluded from participating in covered transactions by any Federal department or agency.
2. Where the prospective lower tier participant is unable to certify to any of the statements in this certification, such prospective participant shall attach an explanation to this proposal.

* * * * *

XI. CERTIFICATION REGARDING USE OF CONTRACT FUNDS FOR LOBBYING

This provision is applicable to all Federal-aid construction contracts and to all related subcontracts which exceed \$100,000 (49 CFR 20).

1. The prospective participant certifies, by signing and submitting this bid or proposal, to the best of his or her knowledge and belief, that:
 - a. No Federal appropriated funds have been paid or will be paid, by or on behalf of the undersigned, to any person for influencing or attempting to influence an officer or employee of any Federal agency, a Member of Congress, an officer or employee of Congress, or an employee of a Member of Congress in connection with the awarding of any Federal contract, the making of any Federal grant, the making of any Federal loan, the entering into of any cooperative agreement, and the extension, continuation, renewal, amendment, or modification of any Federal contract, grant, loan, or cooperative agreement.
 - b. If any funds other than Federal appropriated funds have been paid or will be paid to any person for influencing or attempting to influence an officer or employee of any Federal agency, a Member of Congress, an officer or employee of Congress, or an employee of a Member of Congress in connection with this Federal contract, grant, loan, or cooperative agreement, the undersigned shall complete and submit Standard Form-LLL, "Disclosure Form to Report Lobbying," in accordance with its instructions.
2. This certification is a material representation of fact upon which reliance was placed when this transaction was made or entered into. Submission of this certification is a prerequisite for making or entering into this transaction imposed by 31 U.S.C. 1352. Any person who fails to file the required certification shall be subject to a civil penalty of not less than \$10,000 and not more than \$100,000 for each such failure.
3. The prospective participant also agrees by submitting its bid or proposal that the participant shall require that the language of this certification be included in all lower tier subcontracts, which exceed \$100,000 and that all such recipients shall certify and disclose accordingly.

STANDARD SPECIAL PROVISION**ON-THE-JOB TRAINING**

(10-16-07) (Rev. 4-21-15)

Z-10

Description

The North Carolina Department of Transportation will administer a custom version of the Federal On-the-Job Training (OJT) Program, commonly referred to as the Alternate OJT Program. All contractors (existing and newcomers) will be automatically placed in the Alternate Program. Standard OJT requirements typically associated with individual projects will no longer be applied at the project level. Instead, these requirements will be applicable on an annual basis for each contractor administered by the OJT Program Manager.

On the Job Training shall meet the requirements of 23 CFR 230.107 (b), 23 USC – Section 140, this provision and the On-the-Job Training Program Manual.

The Alternate OJT Program will allow a contractor to train employees on Federal, State and privately funded projects located in North Carolina. However, priority shall be given to training employees on NCDOT Federal-Aid funded projects.

Minorities and Women

Developing, training and upgrading of minorities and women toward journeyman level status is a primary objective of this special training provision. Accordingly, the Contractor shall make every effort to enroll minority and women as trainees to the extent that such persons are available within a reasonable area of recruitment. This training commitment is not intended, and shall not be used, to discriminate against any applicant for training, whether a member of a minority group or not.

Assigning Training Goals

The Department, through the OJT Program Manager, will assign training goals for a calendar year based on the contractors' past three years' activity and the contractors' anticipated upcoming year's activity with the Department. At the beginning of each year, all contractors eligible will be contacted by the Department to determine the number of trainees that will be assigned for the upcoming calendar year. At that time the Contractor shall enter into an agreement with the Department to provide a self-imposed on-the-job training program for the calendar year. This agreement will include a specific number of annual training goals agreed to by both parties. The number of training assignments may range from 1 to 15 per contractor per calendar year. The Contractor shall sign an agreement to fulfill their annual goal for the year.\

Training Classifications

The Contractor shall provide on-the-job training aimed at developing full journeyman level workers in the construction craft/operator positions. Preference shall be given to providing training in the following skilled work classifications:

| | |
|---------------------|----------------------------------|
| Equipment Operators | Office Engineers |
| Truck Drivers | Estimators |
| Carpenters | Iron / Reinforcing Steel Workers |
| Concrete Finishers | Mechanics |
| Pipe Layers | Welders |

The Department has established common training classifications and their respective training requirements that may be used by the contractors. However, the classifications established are not all-inclusive. Where the training is oriented toward construction applications, training will be allowed in lower-level management positions such as office engineers and estimators. Contractors shall submit new classifications for specific job functions that their employees are performing. The Department will review and recommend for acceptance to FHWA the new classifications proposed by contractors, if applicable. New classifications shall meet the following requirements:

Proposed training classifications are reasonable and realistic based on the job skill classification needs, and

The number of training hours specified in the training classification is consistent with common practices and provides enough time for the trainee to obtain journeyman level status.

The Contractor may allow trainees to be trained by a subcontractor provided that the Contractor retains primary responsibility for meeting the training and this provision is made applicable to the subcontract. However, only the Contractor will receive credit towards the annual goal for the trainee.

Where feasible, 25 percent of apprentices or trainees in each occupation shall be in their first year of apprenticeship or training. The number of trainees shall be distributed among the work classifications on the basis of the contractor's needs and the availability of journeymen in the various classifications within a reasonable area of recruitment.

No employee shall be employed as a trainee in any classification in which they have successfully completed a training course leading to journeyman level status or in which they have been employed as a journeyman.

Records and Reports

The Contractor shall maintain enrollment, monthly and completion reports documenting company compliance under these contract documents. These documents and any other information as requested shall be submitted to the OJT Program Manager.

Upon completion and graduation of the program, the Contractor shall provide each trainee with a certification Certificate showing the type and length of training satisfactorily completed.

Trainee Interviews

All trainees enrolled in the program will receive an initial and Trainee/Post graduate interview conducted by the OJT program staff.

Trainee Wages

Contractors shall compensate trainees on a graduating pay scale based upon a percentage of the prevailing minimum journeyman wages (Davis-Bacon Act). Minimum pay shall be as follows:

| | |
|------------|---|
| 60 percent | of the journeyman wage for the first half of the training period |
| 75 percent | of the journeyman wage for the third quarter of the training period |
| 90 percent | of the journeyman wage for the last quarter of the training period |

In no instance shall a trainee be paid less than the local minimum wage. The Contractor shall adhere to the minimum hourly wage rate that will satisfy both the NC Department of Labor (NCDOL) and the Department.

Achieving or Failing to Meet Training Goals

The Contractor will be credited for each trainee employed by him on the contract work who is currently enrolled or becomes enrolled in an approved program and who receives training for at least 50 percent of the specific program requirement. Trainees will be allowed to be transferred between projects if required by the Contractor's scheduled workload to meet training goals.

If a contractor fails to attain their training assignments for the calendar year, they may be taken off the NCDOT's Bidders List.

Measurement and Payment

No compensation will be made for providing required training in accordance with these contract documents.

STANDARD SPECIAL PROVISION

NAME CHANGE FOR NCDENR

(1-19-16)

Z-11

Description

Wherever in the 2012 Standard Specifications, Project Special Provisions, Standard Special Provisions, Permits or Plans that reference is made to “NCDENR” or “North Carolina Department of Environment and Natural Resources”, replace with “NCDEQ” or “North Carolina Department of Environmental Quality” respectively, as the case may be.

STANDARD SPECIAL PROVISION
MINIMUM WAGES
GENERAL DECISION NC160100 01/06/2017 NC100

Z-100

Date: January 6, 2017

General Decision Number: NC170100 01/6/2017 NC100

Superseded General Decision Numbers: NC20160100

State: North Carolina

Construction Type: HIGHWAY

COUNTIES:

| | | |
|-----------|----------|-----------|
| Alexander | Caldwell | Henderson |
| Buncombe | Catawba | Madison |
| Burke | Haywood | |

HIGHWAY CONSTRUCTION PROJECTS (excluding tunnels, building structures in rest area projects & railroad construction; bascule, suspension & spandrel arch bridges designed for commercial navigation, bridges involving marine construction; and other major bridges).

Note: Under Executive Order (EO) 13658, an hourly minimum wage of \$10.20 for calendar year 2017 applies to all contracts subject to the Davis-Bacon Act for which the contract is awarded (and any solicitation was issued) on or after January 1, 2015. If this contract is covered by the EO, the contractor must pay all workers in any classification listed on this wage determination at least \$10.20 per hour (or the applicable wage rate listed on this wage determination, if it is higher) for all hours spent performing on the contract for calendar year 2017. The EO minimum wage rate will be adjusted annually. Additional information on contractor requirements and worker protections under the EO is available at www.dol.gov/whd/govcontracts.

Modification Number
0

Publication Date
01/06/2017

SUNC2014-002 11/13/2014

| | Rates | Fringes |
|---------------------------------------|-------|---------|
| BLASTER | 20.93 | |
| CARPENTER | 13.48 | |
| CEMENT MASON/CONCRETE FINISHER | 14.40 | |
| ELECTRICIAN | | |
| Electrician | 18.79 | 2.62 |
| Telecommunications Technician | 14.67 | 1.67 |
| IRONWORKER | 12.48 | |
| LABORER | | |
| Asphalt Raker and Spreader | 11.76 | |
| Asphalt Screed/Jackman | 15.38 | .08 |
| Carpenter Tender | 10.50 | |
| Cement Mason/Concrete Finisher Tender | 11.04 | |
| Common or General | 11.90 | |
| Guardrail/Fence Installer | 13.09 | |

| | Rates | Fringes |
|---|-------|---------|
| Pipelayer | 12.87 | |
| Traffic Signal/Lighting Installer | 15.33 | .22 |
| PAINTER | | |
| Bridge | 20.67 | |
| POWER EQUIPMENT OPERATORS | | |
| Asphalt Broom Tractor | 10.00 | |
| Bulldozer Fine | 16.28 | |
| Bulldozer Rough | 14.51 | |
| Concrete Grinder/Groover | 19.20 | |
| Crane Boom Trucks | 18.19 | |
| Crane Other | 18.69 | |
| Crane Rough/All-Terrain | 19.19 | |
| Drill Operator Rock | 15.00 | |
| Drill Operator Structure | 21.07 | |
| Excavator Fine | 16.02 | |
| Excavator Rough | 14.67 | |
| Grader/Blade Fine | 19.86 | |
| Grader/Blade Rough | 15.12 | |
| Loader 2 Cubic Yards or Less | 12.38 | |
| Loader Greater Than 2 Cubic Yards | 17.91 | |
| Material Transfer Vehicle (Shuttle Buggy) | 15.44 | |
| Mechanic | 17.86 | |
| Milling Machine | 15.08 | |
| Off-Road Hauler/Water Tanker | 11.95 | |
| Oiler/Greaser | 15.05 | |
| Pavement Marking Equipment | 11.99 | |
| Paver Asphalt | 17.84 | .08 |
| Paver Concrete | 18.20 | |
| Roller Asphalt Breakdown | 15.00 | .08 |
| Roller Asphalt Finish | 16.08 | .07 |
| Roller Other | 12.51 | .03 |
| Scraper Finish | 12.86 | |
| Scraper Rough | 13.83 | |
| Slip Form Machine | 20.38 | |
| Tack Truck/Distributor Operator | 14.81 | .02 |
| TRUCK DRIVER | | |
| GVWR of 26,000 Lbs or Greater | 13.65 | |
| GVWR of 26,000 Lbs or Less | 12.48 | |

Welders – Receive rate prescribed for craft performing operation to which welding is incidental.

Note: Executive Order (EO) 13706, Establishing Paid Sick Leave for Federal Contractors applies to all contracts subject to the Davis-Bacon Act for which the contract is awarded (and any solicitation was issued) on or after January 1, 2017. If this contract is covered by the EO, the contractor must provide employees with 1 hour of paid sick leave for every 30 hours they work, up to 56 hours of paid sick leave each year. Employees must be permitted to use paid sick leave for their own illness, injury or other health-related needs, including preventive care; to assist a family member (or person who is like family to the employee) who is ill, injured, or has other health-related needs, including preventive care; or for reasons resulting from, or to assist a family member (or person who is like family to the employee) who is a victim of, domestic violence,

sexual assault, or stalking. Additional information on contractor requirements and worker protections under the EO is available at www.dol.gov/whd/govcontracts.

Unlisted classifications needed for work not included within the scope of the classifications listed may be added after award only as provided in the labor standards contract clauses (29 CFR 5.5(a)(1)(ii)).

The body of each wage determination lists the classification and wage rates that have been found to be prevailing for the cited type(s) of construction in the area covered by the wage determination. The classifications are listed in alphabetical order of "identifiers" that indicate whether the particular rate is a union rate (current union negotiated rate for local), a survey rate (weighted average rate) or a union average rate (weighted union average rate).

Union Rate Identifiers

A four letter classification abbreviation identifier enclosed in dotted lines beginning with characters other than "SU" or "UAVG" denotes that the union classification and rate were prevailing for that classification in the survey. Example: PLUM0198-005 07/01/2014. PLUM is an abbreviation identifier of the union which prevailed in the survey for this classification, which in this example would be Plumbers. 0198 indicates the local union number or district council number where applicable, i.e., Plumbers Local 0198. The next number, 005 in the example, is an internal number used in processing the wage determination. 07/01/2014 is the effective date of the most current negotiated rate, which in this example is July 1, 2014.

Union prevailing wage rates are updated to reflect all rate changes in the collective bargaining agreement (CBA) governing this classification and rate.

Survey Rate Identifiers

Classifications listed under the "SU" identifier indicate that no one rate prevailed for this classification in the survey and the published rate is derived by computing a weighted average rate based on all the rates reported in the survey for that classification. As this weighted average rate includes all rates reported in the survey, it may include both union and non-union rates. Example: SULA2012-007 5/13/2014. SU indicates the rates are survey rates based on a weighted average calculation of rates and are not majority rates. LA indicates the State of Louisiana. 2012 is the year of survey on which these classifications and rates are based. The next number, 007 in the example, is an internal number used in producing the wage determination. 5/13/2014 indicates the survey completion date for the classifications and rates under that identifier.

Survey wage rates are not updated and remain in effect until a new survey is conducted.

Union Average Rate Identifiers

Classification(s) listed under the UAVG identifier indicate that no single majority rate prevailed for those classifications; however, 100% of the data reported for the classifications was union data. EXAMPLE: UAVG-OH-0010 08/29/2014. UAVG indicates that the rate is a weighted union average rate. OH indicates the state. The next number, 0010 in the example, is an internal number

used in producing the wage determination. 08/29/2014 indicates the survey completion date for the classifications and rates under that identifier.

A UAVG rate will be updated once a year, usually in January of each year, to reflect a weighted average of the current negotiated/CBA rate of the union locals from which the rate is based.

WAGE DETERMINATION APPEALS PROCESS

1.) Has there been an initial decision in the matter? This can be:

- * an existing published wage determination
- * a survey underlying a wage determination
- * a Wage and Hour Division letter setting forth a position on a wage determination matter
- * a conformance (additional classification and rate) ruling

On survey related matters, initial contact, including requests for summaries of surveys, should be with the Wage and Hour Regional Office for the area in which the survey was conducted because those Regional Offices have responsibility for the Davis-Bacon survey program. If the response from this initial contact is not satisfactory, then the process described in 2.) and 3.) should be followed.

With regard to any other matter not yet ripe for the formal process described here, initial contact should be with the Branch of Construction Wage Determinations. Write to:

Branch of Construction Wage Determinations
Wage and Hour Division
U. S. Department of Labor
200 Constitution Avenue, N.W.
Washington, D.C. 20210

2.) If the answer to the question in 1.) is yes, then an interested party (those affected by the action) can request review and reconsideration from the Wage and Hour Administrator (See 29 CFR Part 1.8 and 29 CFR Part 7). Write to:

Wage and Hour Administrator
U.S. Department of Labor
200 Constitution Avenue, N.W.
Washington, D.C. 20210

The request should be accompanied by a full statement of the interested party's position and by any information (wage payment data, project description, area practice material, etc.) that the requestor considers relevant to the issue.

3.) If the decision of the Administrator is not favorable, an interested party may appeal directly to the Administrative Review Board (formerly the Wage Appeals Board). Write to:

Administrative Review Board
U.S. Department of Labor
200 Constitution Avenue, N.W.
Washington, D.C. 20210

4.) All decisions by the Administrative Review Board are final. END OF GENERAL DECISION

U-4715B

ITS-1

Buncombe County

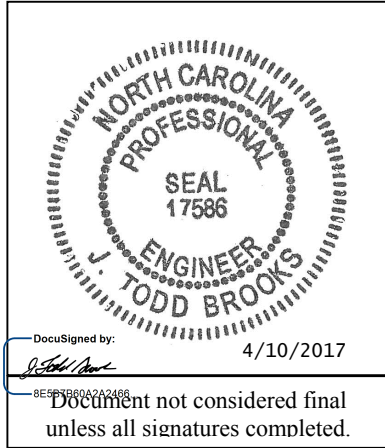

PROJECT SPECIAL PROVISIONS
Asheville Computerized Signal System

N.C. Project No. U-4715B (WBS # 39079.3.4)
F.A. Project No. STP-1302 (069)

Based On
NCDOT ITS and Signals Project Special Provisions
Version 12.5

Prepared by:

ATKINS

1616 East Millbrook Road, Suite 160
 Raleigh, NC 27609 • NCBEES # F-0326

Contents

1. GENERAL REQUIREMENTS.....16

1.1. DESCRIPTION 17

 A. Summary of Work..... 17

 B. Specifications and Special Provisions 19

 C. Coordination of Plans, Specifications, and Special Provisions 19

1.2. MATERIALS 20

 A. Qualified Products 20

 B. Submittal Requirements..... 20

 C. Observation Period..... 20

 D. Warranties..... 21

 E. Firmware Licensing and Upgrades 21

 F. Wire and Cable 22

 G. Painting 22

 H. Performance of Warranty Repair and Maintenance..... 22

1.3. CONSTRUCTION METHODS 22

 A. General 22

 B. Contractor’s Office 23

 C. Work within Historic Districts..... 23

 D. Existing Granite Curb 25

 E. Work within the Special Business Districts..... 26

 F. Special Pedestrian Considerations around A-B Tech Campus 26

 G. Regulations and Codes..... 26

 H. Utility Services..... 27

 I. Maintenance and Repair of Material..... 27

 J. Inspections 29

 K. Removal of Existing Equipment and Material..... 29

 L. Railroad Preemption 29

 M. Timing of Signals..... 30

 N. Wire and Cable 31

 O. Electrical Services and Grounding..... 31

◆ **Revision No. 1, April 10, 2017 – This document supersedes version originally issued and sealed by J. Todd Brooks, NCPE No. 017586 on 12/28/2016.**

| | | |
|-----------|--|-----------|
| P. | Electrical Bonding | 32 |
| Q. | Traffic Signal Activation | 32 |
| R. | Requirements for Cables Crossing Railroads | 32 |
| 1.4. | CONSTRUCTION STAGING/MIGRATION | 36 |
| A. | Introduction..... | 36 |
| B. | General Requirements..... | 37 |
| C. | Staging Concept..... | 39 |
| D. | Field Infrastructure – Stages 1-4..... | 41 |
| E. | Communications Migration – Stage 2 | 43 |
| F. | Communications Migration – Stage 3 | 45 |
| G. | Communications Migration – Stage 4 | 46 |
| H. | TMC Migration – Stage 4..... | 47 |
| 1.5. | MEASUREMENT AND PAYMENT | 48 |
| 2. | TEMPORARY TRAFFIC CONTROL | 49 |
| 2.1. | DESCRIPTION | 49 |
| 2.2. | GENERAL REQUIREMENTS..... | 49 |
| A. | Maintenance of Traffic | 49 |
| B. | Temporary Lane Closures..... | 49 |
| C. | Traffic Stoppage..... | 50 |
| D. | Traffic Control Supervision | 50 |
| E. | Vehicular Access | 50 |
| F. | Pedestrian Access..... | 50 |
| G. | Greenways..... | 51 |
| H. | Alternate to Transportation Management Plan | 51 |
| I. | Temporary Traffic Control Plan not fully Covered in the Contract | 51 |
| 2.3. | MATERIALS | 51 |
| A. | Work Zone Traffic Control Devices | 51 |
| B. | Work Zone Signs | 52 |
| C. | Flashing Arrow Boards..... | 52 |
| D. | Portable Changeable Message Signs | 52 |
| E. | Drums..... | 52 |
| F. | Cones..... | 53 |
| G. | Barricades | 53 |
| H. | Flaggers..... | 53 |
| I. | Truck Mounted Attenuators..... | 53 |
| J. | Skinny Drums | 53 |
| 2.4. | CONSTRUCTION METHODS | 54 |
| A. | Work Zone Traffic Control Devices | 54 |
| B. | Work Zone Signs | 54 |
| C. | Flashing Arrow Boards..... | 54 |
| D. | Portable Changeable Message Signs | 54 |
| E. | Drums..... | 55 |
| F. | Cones..... | 55 |
| G. | Barricades | 56 |
| H. | Flaggers..... | 56 |
| I. | Truck Mounted Attenuator | 56 |

◆ **Revision No. 1, April 10, 2017 – This document supersedes version originally issued and sealed by J. Todd Brooks, NCPE No. 017586 on 12/28/2016.**

| | | |
|-----------|--|-----------|
| J. | Skinny Drums | 57 |
| K. | Law Enforcement..... | 57 |
| L. | Pedestrian Safety..... | 57 |
| 2.5. | MAINTENANCE AND INSPECTION | 58 |
| A. | Work Zone Traffic Control Devices..... | 58 |
| 2.6. | FAILURE TO MAINTAIN TRAFFIC CONTROL | 58 |
| 2.7. | MEASUREMENT AND PAYMENT | 58 |
| 3. | PAVEMENT MARKINGS | 61 |
| 3.1. | DESCRIPTION | 61 |
| 3.2. | MATERIALS | 61 |
| A. | General..... | 61 |
| B. | Material Qualification..... | 61 |
| C. | Historical Performance | 61 |
| 3.3. | CONSTRUCTION METHODS | 61 |
| A. | General..... | 61 |
| B. | Testing Procedures..... | 61 |
| C. | Application Equipment | 61 |
| D. | Weather Limitations and Seasonal Limitations | 62 |
| E. | Time Limitations for Replacement..... | 62 |
| F. | Premarking/Interim/Temporary Markings..... | 62 |
| G. | Surface Preparation and Curing Compound Removal..... | 63 |
| H. | Application of Pavement Markings | 63 |
| I. | Pavement Markings Observation Period | 64 |
| J. | Removal of Pavement Markings..... | 65 |
| K. | Pavement Marking Installer Qualifications | 66 |
| 3.4. | THERMOPLASTIC (ALKYD/MALEIC)..... | 66 |
| A. | Application Equipment | 66 |
| B. | Weather Limitations and Seasonal Limitations | 67 |
| C. | Application..... | 67 |
| D. | Thermoplastic Marking Observation Period..... | 68 |
| 3.5. | MAINTENANCE..... | 68 |
| 3.6. | MEASUREMENT AND PAYMENT | 68 |
| 4. | SIGNAL HEADS | 70 |
| 4.1. | DESCRIPTION | 70 |
| 4.2. | MATERIALS | 70 |
| A. | General..... | 70 |
| B. | Vehicle Signal Heads..... | 72 |
| C. | LED U-Turn Arrow Signal Modules:..... | 74 |
| D. | Pedestrian Signal Heads:..... | 75 |
| E. | Signal Cable..... | 76 |
| 4.3. | CONSTRUCTION METHODS | 77 |
| A. | General..... | 77 |
| B. | Vehicle Signal Heads..... | 77 |
| C. | Pedestrian Signal Heads..... | 78 |
| 4.4. | MEASUREMENT AND PAYMENT | 79 |

| | |
|--|-----------|
| 5. PUSHBUTTON INTEGRATED ACCESSIBLE PEDESTRIAN SIGNAL (APS) | 80 |
| 5.1. DESCRIPTION | 80 |
| 5.2. MATERIALS | 80 |
| 5.3. CONSTRUCTION METHODS | 81 |
| 5.4. MEASUREMENT AND PAYMENT | 81 |
| 6. MESSENGER CABLE..... | 83 |
| 6.1. DESCRIPTION | 83 |
| 6.2. MATERIALS | 83 |
| A. General | 83 |
| B. Messenger Cable | 83 |
| C. Pole Line Hardware | 83 |
| D. Grounding Electrodes | 84 |
| 6.3. CONSTRUCTION METHODS | 84 |
| A. General | 84 |
| B. Messenger Cable for Signal Heads or Loop Lead-In Cable | 85 |
| C. Messenger Cable for Communications Cable | 85 |
| D. Messenger Cable for Multiple Cables | 85 |
| 6.4. MEASUREMENT AND PAYMENT | 86 |
| 7. UNDERGROUND CONDUIT..... | 87 |
| 7.1. DESCRIPTION | 87 |
| 7.2. MATERIALS | 87 |
| A. General | 87 |
| B. Conduit Bodies, Boxes and Fittings | 87 |
| C. Conduit Types | 87 |
| D. Conduit Plugs, Pull Line, and Tracer Wire | 89 |
| E. Mechanical Couplings for HDPE Conduit | 90 |
| F. Duct and Conduit Sealer | 90 |
| 7.3. CONSTRUCTION METHODS | 90 |
| A. General | 90 |
| B. Trenching | 92 |
| C. Plowing (HDPE Conduit Only) | 94 |
| D. Directional Drilling | 94 |
| E. Maximum Length of Directional Drill | 96 |
| F. Splicing and Coupling of HDPE Conduit | 97 |
| 7.4. MEASUREMENT AND PAYMENT | 97 |
| 8. JUNCTION BOXES | 99 |
| 8.1. DESCRIPTION | 99 |
| 8.2. MATERIALS | 99 |
| A. General | 99 |
| B. Polymer Concrete (PC) Junction Boxes | 99 |
| C. Junction Box Sizes | 100 |
| 8.3. CONSTRUCTION METHODS | 100 |
| A. General | 100 |
| B. GPS Coordinates | 101 |

| | |
|--|------------|
| 8.4. MEASUREMENT AND PAYMENT | 101 |
| 9. BEAUCATCHER TUNNEL CONDUIT SYSTEM | 103 |
| 9.1. DESCRIPTION | 103 |
| 9.2. MATERIALS | 103 |
| A. Surface Mounted Junction Boxes | 103 |
| B. Conduit, Conduit Bodies, Conduit Fasteners and Fittings..... | 103 |
| C. Concrete Anchors..... | 104 |
| D. Concrete for Sidewalk Repair/Replacement | 104 |
| 9.3. CONSTRUCTION METHODS | 104 |
| A. General..... | 104 |
| 9.4. MEASUREMENT AND PAYMENT | 105 |
| 10. EXTENSION OF EXISTING FIELD WIRING AT CONTROLLER CABINETS ... | 107 |
| 10.1. DESCRIPTION | 107 |
| 10.2. MATERIALS | 107 |
| A. Terminal Blocks..... | 107 |
| B. Terminal Splice Cabinets | 107 |
| C. Gel-Filled Splice Connectors..... | 108 |
| D. Signal Cable and Loop Lead-In Cable..... | 108 |
| 10.3. CONSTRUCTION METHODS | 108 |
| A. General..... | 108 |
| B. Inside Controller Cabinets | 108 |
| C. External to Controller Cabinets | 108 |
| D. Terminal Splice Cabinets..... | 109 |
| E. Terminal Splice Cabinet Where Existing Cabinet is Base-Mounted..... | 110 |
| 10.4. MEASUREMENT AND PAYMENT | 110 |
| 11. WOOD POLES | 112 |
| 11.1. DESCRIPTION | 112 |
| 11.2. MATERIALS | 112 |
| A. General..... | 112 |
| B. Wood Poles for Antennas | 112 |
| C. CCTV Wood Poles | 112 |
| 11.3. CONSTRUCTION METHODS | 112 |
| 11.4. MEASUREMENT AND PAYMENT | 114 |
| 12. GUY ASSEMBLIES | 115 |
| 12.1. DESCRIPTION | 115 |
| 12.2. MATERIALS | 115 |
| 12.3. CONSTRUCTION METHODS | 115 |
| A. General..... | 115 |
| B. Guy Assemblies for Signal Heads or Loop Lead-in Cable..... | 115 |
| C. Guy Assemblies for Communications Cable..... | 116 |
| 12.4. MEASUREMENT AND PAYMENT | 116 |
| 13. RISER ASSEMBLIES..... | 118 |
| 13.1. DESCRIPTION | 118 |

◆ **Revision No. 1, April 10, 2017 – This document supersedes version originally issued and sealed by J. Todd Brooks, NCPE No. 017586 on 12/28/2016.**

| | |
|---|------------|
| 13.2. MATERIALS | 118 |
| 13.3. CONSTRUCTION METHODS | 119 |
| 13.4. MEASUREMENT AND PAYMENT | 121 |
| 14. INDUCTIVE DETECTION LOOPS | 124 |
| 14.1. DESCRIPTION | 124 |
| 14.2. MATERIALS | 124 |
| A. Loop Sealant | 124 |
| B. Loop Wire | 124 |
| C. Conduit..... | 125 |
| 14.3. CONSTRUCTION METHODS | 125 |
| 14.4. MEASUREMENT AND PAYMENT | 126 |
| 15. LEAD-IN CABLE..... | 127 |
| 15.1. DESCRIPTION | 127 |
| 15.2. MATERIALS | 127 |
| 15.3. CONSTRUCTION METHODS | 127 |
| 15.4. MEASUREMENT AND PAYMENT | 128 |
| 16. MICROWAVE VEHICLE DETECTION SYSTEM - MULTIPLE DETECTION ZONES..... | 129 |
| 16.1. DESCRIPTION | 129 |
| 16.2. MATERIALS | 129 |
| 16.3. CONSTRUCTION METHODS | 130 |
| 16.4. MEASUREMENT AND PAYMENT | 130 |
| 17. FIBER-OPTIC CABLE..... | 131 |
| 17.1. DESCRIPTION | 131 |
| 17.2. MATERIALS | 131 |
| A. General..... | 131 |
| B. SMFO Communications Cable | 131 |
| C. Drop Cable | 133 |
| D. Communications Cable Identification Markers | 133 |
| E. Fiber-Optic Cable Storage Guides | 134 |
| F. Aerial Cable Protectors | 134 |
| 17.3. CONSTRUCTION METHODS | 134 |
| A. General | 134 |
| B. Aerial Installation..... | 135 |
| C. Underground Installation | 136 |
| D. Indoor Installation..... | 136 |
| E. Installation of Drop Cable..... | 137 |
| F. Aerial Cable Protector..... | 138 |
| 17.4. MEASUREMENT AND PAYMENT | 138 |
| 18. FIBER-OPTIC SPLICE CENTERS..... | 140 |
| 18.1. DESCRIPTION | 140 |
| 18.2. MATERIALS | 140 |
| A. Interconnect Center..... | 140 |

◆ **Revision No. 1, April 10, 2017 – This document supersedes version originally issued and sealed by J. Todd Brooks, NCPE No. 017586 on 12/28/2016.**

U-4715B

ITS-7

Buncombe County

| | | |
|------------|--|------------|
| B. | Splice Enclosure..... | 140 |
| C. | Existing Splice Enclosures..... | 141 |
| 18.3. | CONSTRUCTION METHODS..... | 141 |
| A. | General (Workmanship Identification Information)..... | 141 |
| B. | Workmanship..... | 141 |
| C. | Termination and Splicing within Interconnect Centers..... | 142 |
| D. | Interconnect Centers in Controller and CCTV Cabinets..... | 142 |
| E. | Replacement of Interconnect Centers Installed under STIP Project I-5504..... | 142 |
| F. | Termination and Splicing within Splice Enclosure..... | 143 |
| G. | Modify Existing Splice..... | 144 |
| H. | Testing..... | 144 |
| 18.4. | MEASUREMENT AND PAYMENT..... | 145 |
| 19. | DELINEATOR MARKERS..... | 146 |
| 19.1. | DESCRIPTION..... | 146 |
| 19.2. | MATERIALS..... | 146 |
| A. | Delineator Markers..... | 146 |
| 19.3. | CONSTRUCTION METHODS..... | 147 |
| A. | Delineator Markers in Historic Districts..... | 147 |
| B. | Delineator Markers..... | 147 |
| 19.4. | MEASUREMENT AND PAYMENT..... | 147 |
| 20. | REMOVE EXISTING COMMUNICATIONS CABLE..... | 148 |
| 20.1. | DESCRIPTION..... | 148 |
| 20.2. | MATERIALS..... | 148 |
| 20.3. | CONSTRUCTION METHODS..... | 148 |
| A. | General..... | 148 |
| B. | Removal of Aerial Communications Cable..... | 148 |
| C. | Removal of Underground Communications Cable..... | 149 |
| D. | Removal of Splice/Hub Cabinet..... | 149 |
| 20.4. | MEASUREMENT AND PAYMENT..... | 150 |
| 21. | CABLE TRANSFERS..... | 152 |
| 21.1. | DESCRIPTION..... | 152 |
| 21.2. | CONSTRUCTION METHODS..... | 152 |
| 21.3. | MEASUREMENT AND PAYMENT..... | 152 |
| 22. | SIGNAL PEDESTALS..... | 153 |
| 22.1. | DESCRIPTION..... | 153 |
| 22.2. | MATERIALS..... | 153 |
| A. | Pedestal Shaft..... | 153 |
| B. | Transformer Bases..... | 154 |
| C. | Anchor Bolts..... | 154 |
| D. | Pedestal Cap..... | 155 |
| E. | Pole Flange Base for 4 1/2" Pipe..... | 155 |
| F. | Breakaway Anchors..... | 155 |
| G. | Foundation..... | 155 |
| 22.3. | CONSTRUCTION METHODS..... | 155 |

◆ **Revision No. 1, April 10, 2017 – This document supersedes version originally issued and sealed by J. Todd Brooks, NCPE No. 017586 on 12/28/2016.**

U-4715B

ITS-8

Buncombe County

| | | |
|------------|--|------------|
| A. | Type I Pedestrian Pushbutton Post | 155 |
| B. | Type II and III Pedestals | 156 |
| 22.4. | MEASUREMENT AND PAYMENT | 156 |
| 23. | SIGNS INSTALLED FOR SIGNALS | 157 |
| 23.1. | DESCRIPTION | 157 |
| 23.2. | MATERIALS | 157 |
| 23.3. | CONSTRUCTION METHODS | 157 |
| 23.4. | MEASUREMENT AND PAYMENT | 157 |
| 24. | RELOCATE EXISTING SIGN..... | 158 |
| 24.1. | DESCRIPTION | 158 |
| 24.2. | CONSTRUCTION METHODS | 158 |
| 24.3. | MEASUREMENT AND PAYMENT | 158 |
| 25. | EQUIPMENT CABINET FOUNDATIONS | 159 |
| 25.1. | DESCRIPTION | 159 |
| 25.2. | MATERIALS | 159 |
| 25.3. | CONSTRUCTION METHODS | 159 |
| 25.4. | MEASUREMENT AND PAYMENT | 161 |
| 26. | MODIFY CABINET FOUNDATIONS | 162 |
| 26.1. | DESCRIPTION | 162 |
| 26.2. | MATERIALS | 162 |
| 26.3. | CONSTRUCTION METHODS | 162 |
| A. | General..... | 162 |
| B. | Install Conduit Entrance into Existing Foundation..... | 162 |
| C. | Modify Foundation | 162 |
| D. | Alternate Methods of Modifying Foundations | 163 |
| E. | Ground Surface Restoration..... | 165 |
| 26.4. | MEASUREMENT AND PAYMENT | 165 |
| 27. | CONTROLLERS WITH CABINETS | 166 |
| 27.1. | DESCRIPTION | 166 |
| 27.2. | MATERIALS - GENERAL..... | 166 |
| 27.3. | MATERIALS – TYPE 2070E CONTROLLERS | 166 |
| 27.4. | MATERIALS – GENERAL CABINETS..... | 166 |
| 27.5. | MATERIALS – TYPE 170E CABINETS | 167 |
| A. | Type 170 E Cabinets General | 167 |
| B. | Special Coating for Cabinets | 168 |
| C. | Type 170 E Cabinet Electrical Requirements..... | 168 |
| D. | Type 170 E Cabinet Physical Requirements..... | 175 |
| 27.6. | MATERIALS – MODEL 2018 ENHANCED CONFLICT MONITOR..... | 177 |
| 27.7. | MATERIALS – PREEMPTION AND SIGN CONTROL BOX..... | 186 |
| 27.8. | MATERIALS – TYPE 170 DETECTOR SENSOR UNITS | 189 |
| 27.9. | CONSTRUCTION METHODS | 189 |
| A. | General..... | 189 |
| B. | Electrical Service and Grounding..... | 191 |

◆ **Revision No. 1, April 10, 2017 – This document supersedes version originally issued and sealed by J. Todd Brooks, NCPE No. 017586 on 12/28/2016.**

U-4715B

ITS-9

Buncombe County

| | | |
|------------|---|------------|
| C. | Edge Switch | 191 |
| D. | Workshop | 191 |
| E. | GPS Coordinates | 191 |
| 27.10. | MEASUREMENT AND PAYMENT | 192 |
| 28. | CABINET BASE ADAPTER AND BASE EXTENDER | 194 |
| 28.1. | DESCRIPTION | 194 |
| 28.2. | MATERIALS | 194 |
| 28.3. | CONSTRUCTION METHODS | 194 |
| A. | General | 194 |
| B. | Installation on Pedestal Bases Downtown | 195 |
| 28.4. | MEASUREMENT AND PAYMENT | 195 |
| 29. | SPECIAL COATING FOR CABINETS | 196 |
| 29.1. | DESCRIPTION | 196 |
| 29.2. | MATERIALS | 196 |
| 29.3. | CONSTRUCTION METHODS | 196 |
| 29.4. | MEASUREMENT AND PAYMENT | 196 |
| 30. | ELECTRICAL SERVICE | 198 |
| 30.1. | DESCRIPTION | 198 |
| 30.2. | MATERIALS | 198 |
| A. | Electrical Service | 198 |
| B. | CCTV Cabinet Disconnect | 200 |
| C. | Grounding Electrodes (Ground Rods) | 201 |
| 30.3. | CONSTRUCTION METHODS | 201 |
| A. | General | 201 |
| B. | New Electrical Service for Traffic Signal | 202 |
| C. | New Electrical Service for CCTV | 202 |
| D. | New Shared Electrical Service for Traffic Signal and CCTV | 202 |
| E. | Modify Existing Electrical Service | 203 |
| F. | Disconnect for CCTV Cabinet | 203 |
| G. | Grounding of Electrical Services | 203 |
| 30.4. | MEASUREMENT AND PAYMENT | 204 |
| 31. | SOLAR POWER ASSEMBLY | 206 |
| 31.1. | DESCRIPTION | 206 |
| 31.2. | MATERIALS | 206 |
| A. | Solar Array | 206 |
| B. | Solar Charge Controller | 206 |
| C. | Batteries | 206 |
| D. | Solar Power Assembly Cabinet | 206 |
| 31.3. | CONSTRUCTION METHODS | 207 |
| 31.4. | MEASUREMENT AND PAYMENT | 207 |
| 32. | 900 MHZ ETHERNET RADIO | 208 |
| 32.1. | DESCRIPTION | 208 |
| 32.2. | MATERIALS | 208 |

◆ **Revision No. 1, April 10, 2017 – This document supersedes version originally issued and sealed by J. Todd Brooks, NCPE No. 017586 on 12/28/2016.**

U-4715B

ITS-10

Buncombe County

| | | |
|------------|---|------------|
| A. | General | 208 |
| B. | Standards | 208 |
| C. | 900 MHz Ethernet Radio Transceivers | 208 |
| D. | Software | 210 |
| E. | Directional Antenna (Yagi)..... | 210 |
| F. | Omni Antenna | 212 |
| G. | Panel Antenna | 212 |
| H. | Antenna Mounting Hardware Kit | 213 |
| I. | Coaxial Cable..... | 213 |
| J. | Standard N-Type Male Connector | 214 |
| K. | Coaxial Cable Shield Grounding and Weatherproofing Kits | 214 |
| L. | Lightning Arrestor | 215 |
| M. | Disconnect Switch | 215 |
| N. | Warning Signs(s) and Decal(s)..... | 215 |
| O. | Pole-Mount Radio Cabinet | 216 |
| 32.3. | CONSTRUCTION METHODS | 216 |
| A. | General | 216 |
| B. | Antenna | 217 |
| C. | Cabling..... | 217 |
| D. | Cabinet and Electrical Power Wiring | 217 |
| E. | Disconnect Switch | 218 |
| F. | Warning Sign(s) and Decal(s)..... | 218 |
| G. | Pole-Mount Radio Cabinet | 218 |
| 32.4. | MEASUREMENT AND PAYMENT | 218 |
| 33. | 2.4 GHZ ETHERNET RADIO | 220 |
| 33.1. | DESCRIPTION | 220 |
| A. | Standards | 220 |
| B. | General | 220 |
| 33.2. | MATERIALS | 221 |
| A. | Ethernet Radio | 221 |
| B. | Directional Antenna | 223 |
| C. | Omni Antenna..... | 223 |
| D. | Coaxial Cable..... | 224 |
| E. | Standard N-Type Male Connector | 225 |
| F. | Coaxial Cable Shield Grounding and Weatherproofing Kits | 225 |
| G. | Surge Suppression..... | 225 |
| H. | Pole-Mounting Hardware..... | 226 |
| 33.3. | CONSTRUCTION METHODS | 226 |
| A. | General..... | 226 |
| B. | Site Survey | 226 |
| C. | Configuration | 226 |
| D. | Software | 227 |
| E. | General Requirements for Metal Pole Locations..... | 227 |
| F. | Antenna | 227 |
| G. | Antenna Cabling | 228 |
| H. | Cabinet and Electrical Power Wiring | 228 |

◆ **Revision No. 1, April 10, 2017 – This document supersedes version originally issued and sealed by J. Todd Brooks, NCPE No. 017586 on 12/28/2016.**

| | | |
|------------|---|------------|
| I. | Routing of Cable for Antennas Mounted on Metal Poles..... | 229 |
| J. | Wireless Ethernet Testing..... | 229 |
| K. | Training..... | 230 |
| 33.4. | MEASURMENT AND PAYMENT..... | 230 |
| 34. | ETHERNET CABLE..... | 231 |
| 34.1. | DESCRIPTION..... | 231 |
| 34.2. | MATERIALS..... | 231 |
| A. | Ethernet Cable..... | 231 |
| B. | Cable Management..... | 232 |
| C. | Connectors..... | 233 |
| D. | Ethernet Patch Cords..... | 233 |
| E. | Environmental Requirements..... | 233 |
| 34.3. | CONSTRUCTION METHODS..... | 233 |
| A. | General..... | 233 |
| B. | Aerial Installation..... | 234 |
| C. | Messenger Cable Installation..... | 234 |
| D. | Underground Installation..... | 234 |
| E. | Above-Ceiling Installation..... | 235 |
| F. | Ethernet Patch Cords..... | 235 |
| 34.4. | MEASUREMENT AND PAYMENT..... | 235 |
| 35. | CCTV FIELD EQUIPMENT..... | 236 |
| 35.1. | DESCRIPTION..... | 236 |
| 35.2. | MATERIALS..... | 236 |
| A. | General..... | 236 |
| B. | Standards..... | 237 |
| C. | Camera Assembly..... | 237 |
| D. | Camera Mounting Bracket..... | 239 |
| E. | Video Encoder..... | 240 |
| F. | Type 336A Camera Cabinet..... | 240 |
| G. | Composite Cable..... | 242 |
| H. | Surge Suppression..... | 243 |
| I. | Grounding..... | 244 |
| J. | Software..... | 245 |
| 35.3. | CONSTRUCTION METHODS..... | 245 |
| A. | Electrical and Mechanical Requirements..... | 245 |
| B. | CCTV Cabinet..... | 245 |
| C. | Power Service..... | 246 |
| D. | Grounding..... | 246 |
| E. | Composite Cable..... | 246 |
| F. | Surge Protection..... | 246 |
| G. | CCTV Camera Attachments..... | 247 |
| H. | Cellular Communications..... | 247 |
| I. | Software..... | 247 |
| J. | GPS Coordinates..... | 247 |
| 35.4. | MEASUREMENT AND PAYMENT..... | 248 |

◆ **Revision No. 1, April 10, 2017 – This document supersedes version originally issued and sealed by J. Todd Brooks, NCPE No. 017586 on 12/28/2016.**

| | |
|---|------------|
| 36. CCTV INTEGRATION AND SOFTWARE MODIFICATION | 250 |
| 36.1. DESCRIPTION | 250 |
| 36.2. CONSTRUCTION METHODS | 250 |
| 36.3. MEASUREMENT AND PAYMENT | 250 |
| 37. SIGNAL SYSTEM SOFTWARE | 251 |
| 37.1. DESCRIPTION | 251 |
| 37.2. FUNCTIONAL REQUIREMENTS | 251 |
| A. General | 251 |
| B. Distributed Processing Signal System Software | 253 |
| C. Local Controller Software | 268 |
| D. System Support Software and Devices | 268 |
| 37.3. INSTALLATION AND INTEGRATION | 268 |
| A. General | 268 |
| B. Distributed Processing Signal System Software | 269 |
| C. Local Controller Software | 269 |
| D. System Support Software and Devices | 270 |
| 37.4. TESTING | 270 |
| A. General | 270 |
| B. System Demonstration | 270 |
| 37.5. MEASUREMENT AND PAYMENT | 270 |
| 38. COMPUTER HARDWARE AND PERIPHERALS | 272 |
| 38.1. DESCRIPTION | 272 |
| A. ITS Servers | 272 |
| B. Computer Workstations | 272 |
| C. Laptop Computers | 272 |
| D. Printer | 272 |
| E. KVM Switch | 272 |
| F. UPS | 272 |
| G. Existing Equipment | 272 |
| 38.2. MATERIALS | 273 |
| A. ITS Servers | 273 |
| B. Computer Workstations | 275 |
| C. Laptop Computers | 276 |
| D. Printer | 277 |
| E. KVM Switch | 278 |
| F. UPS | 278 |
| G. Ethernet Patch Panel | 279 |
| 38.3. CONSTRUCTION REQUIREMENTS | 280 |
| A. General | 280 |
| B. ITS Servers | 280 |
| C. Computer Workstation | 280 |
| D. Laptop Computers | 281 |
| E. Printer | 281 |
| F. KVM Switch | 281 |
| G. UPS | 282 |

U-4715B

ITS-13

Buncombe County

| | | |
|------------|---|------------|
| H. | Ethernet Patch Panel | 282 |
| I. | Existing Equipment..... | 282 |
| 38.4. | DOCUMENTATION..... | 282 |
| 38.5. | WARRANTY..... | 282 |
| 38.6. | MEASUREMENT AND PAYMENT..... | 282 |
| 39. | COMMUNICATIONS HARDWARE | 284 |
| 39.1. | DESCRIPTION..... | 284 |
| A. | Ethernet Core Switch | 284 |
| B. | Ethernet Edge Switch..... | 284 |
| C. | Firewall..... | 284 |
| D. | Network Management Software..... | 284 |
| E. | Uninterruptible Power Supply (UPS)..... | 284 |
| 39.2. | MATERIALS..... | 285 |
| A. | General..... | 285 |
| B. | Ethernet Core Switch | 285 |
| C. | Ethernet Edge Switch..... | 290 |
| D. | Firewall..... | 293 |
| E. | Network Management Software..... | 296 |
| F. | Uninterruptible Power Supply (UPS)..... | 297 |
| 39.3. | CONSTRUCTION METHODS..... | 299 |
| A. | General..... | 299 |
| B. | Ethernet Switches..... | 299 |
| C. | Firewall..... | 300 |
| D. | Network Management Software..... | 301 |
| E. | Uninterruptible Power Supply (UPS)..... | 301 |
| 39.4. | MEASUREMENT AND PAYMENT..... | 301 |
| 40. | DIGITAL VIDEO EQUIPMENT | 303 |
| 40.1. | DESCRIPTION..... | 303 |
| 40.2. | MATERIALS..... | 303 |
| A. | Graphics Card for Existing Video Processing Unit..... | 303 |
| B. | Digital Video Monitors..... | 303 |
| C. | Network Video Recorder..... | 304 |
| D. | PTZ Joysticks..... | 305 |
| 40.3. | CONSTRUCTION METHODS..... | 305 |
| A. | General..... | 305 |
| B. | Video Server..... | 305 |
| C. | Digital Video Monitors..... | 305 |
| D. | Network Video Recorder..... | 306 |
| E. | PTZ Joysticks..... | 306 |
| 40.4. | MEASUREMENT AND PAYMENT..... | 306 |
| 41. | COMMUNICATIONS RACKS | 308 |
| 41.1. | DESCRIPTION..... | 308 |
| 41.2. | MATERIALS..... | 308 |
| 41.3. | CONSTRUCTION METHODS..... | 309 |
| 41.4. | MEASUREMENT AND PAYMENT..... | 309 |

◆ **Revision No. 1, April 10, 2017 – This document supersedes version originally issued and sealed by J. Todd Brooks, NCPE No. 017586 on 12/28/2016.**

| | |
|--|------------|
| 42. BUILDING MODIFICATIONS AND FIBER-OPTIC CABLE TERMINATION..... | 310 |
| 42.1. DESCRIPTION | 310 |
| 42.2. MATERIALS | 310 |
| A. General | 310 |
| B. Fiber-Optic Splicing and Termination | 310 |
| C. Traffic Management Center (TMC) Building Modifications | 311 |
| D. City Hall Building Modifications | 312 |
| E. Division 13 Office Building Modifications | 313 |
| 42.3. CONSTRUCTION METHODS | 314 |
| A. General | 314 |
| B. Traffic Management Center (TMC)..... | 315 |
| C. City Hall..... | 316 |
| D. Division 13 Office..... | 318 |
| 42.4. MEASUREMENT AND PAYMENT | 318 |
| 43. SUBMITTAL DATA AND DOCUMENTATION..... | 320 |
| 43.1. DESCRIPTION | 320 |
| 43.2. SUBMITTALS | 320 |
| A. General | 320 |
| B. Project Construction Schedule | 320 |
| C. Qualified Products | 321 |
| D. System Design Report..... | 321 |
| E. Fiber-optic Splicing Drawings | 321 |
| F. Submittal Requirements..... | 321 |
| 43.3. DOCUMENTATION | 323 |
| A. General | 323 |
| B. Plan of Record Documentation | 324 |
| C. Manuals | 325 |
| D. Wiring Diagrams..... | 325 |
| E. Splice Diagrams | 326 |
| 43.4. MEASUREMENT AND PAYMENT | 326 |
| 44. SYSTEM SUPPORT AND TEST EQUIPMENT | 327 |
| 44.1. DESCRIPTION | 327 |
| 44.2. MATERIALS | 327 |
| A. General | 327 |
| B. Fiber-Optic Restoration Kit | 327 |
| C. Spare Cable and Connectors Kit | 328 |
| D. Fiber-Optic Power Meter | 328 |
| E. Optical Light Generator | 328 |
| F. Visual Fault Locator | 329 |
| G. Conflict Monitor Tester with Notebook Computer | 329 |
| H. Ethernet Radio Support Equipment | 330 |
| I. Test Controllers with Cabinets..... | 330 |
| J. CCTV Test Cabinet..... | 331 |
| 44.3. MEASUREMENT AND PAYMENT | 331 |

◆ **Revision No. 1, April 10, 2017 – This document supersedes version originally issued and sealed by J. Todd Brooks, NCPE No. 017586 on 12/28/2016.**

| | |
|--|------------|
| 45. TRAINING | 334 |
| 45.1. DESCRIPTION | 334 |
| 45.2. MATERIALS | 334 |
| A. General | 334 |
| B. Ethernet Communications and Networking | 336 |
| C. Fiber-Optic Cable | 338 |
| D. CCTV Field Equipment | 339 |
| E. Digital Video Equipment | 339 |
| F. Signal System Software | 340 |
| G. 2070 Controllers, Conflict Monitors, Cabinets and Controller Firmware | 340 |
| H. Wireless Communications System | 342 |
| I. UPS | 343 |
| 45.3. MEASUREMENT AND PAYMENT | 343 |
| 46. TESTING AND ACCEPTANCE | 344 |
| 46.1. GENERAL | 344 |
| 46.2. INSTALLED SITE TESTS | 344 |
| A. Fiber-Optic Cable | 345 |
| B. Ethernet Communications System | 345 |
| C. Traffic Signal Controllers and Conflict Monitors | 346 |
| D. Communications System Support Equipment | 347 |
| E. CCTV Field Equipment | 347 |
| F. Digital Video Equipment | 348 |
| G. UPS | 348 |
| H. Ethernet Radio Equipment | 348 |
| 46.3. SYSTEM TESTING | 349 |
| A. General | 349 |
| B. CCTV Subsystem | 349 |
| C. Traffic Signal Subsystem | 350 |
| D. System Operational Test | 350 |
| 46.4. OBSERVATION PERIOD | 352 |
| A. General | 352 |
| B. CCTV Subsystem | 353 |
| C. Traffic Signal Subsystem | 353 |
| 46.5. MEASUREMENT AND PAYMENT | 353 |
| 46.6. FINAL ACCEPTANCE | 353 |

U-4715B

ITS-16

Buncombe County

This page left blank intentionally.

◆ **Revision No. 1, April 10, 2017 – *This document supersedes version originally issued and sealed by J. Todd Brooks, NCPE No. 017586 on 12/28/2016.***

GENERAL REQUIREMENTS

1.1. DESCRIPTION

A. Summary of Work

The purpose of this project is to construct a new computerized traffic signal system in City of Asheville, North Carolina. Work will be primarily comprised of a new communications system, field equipment upgrades, the replacement of multiple independent arterial closed-loop traffic signal systems with a new, centrally managed distributed processing traffic control system, enhancement of the NCDOT Traffic Management Center (TMC), and the upgrade and expansion of the existing video monitoring system. This project includes:

- Signal display upgrades at selected locations and replacement of existing controllers and cabinets with new Model 2070E controllers housed in Model 332 or 336S cabinets for 275 signalized intersections;
- Replacement of multiple independent single-mode fiber-optic and wireless serial communications systems and their dial-up modems with a new Ethernet-based, fault-tolerant, single-mode fiber-optic communications comprised of approximately 78 roadway miles of fiber-optic cable (including approximately 0.68 miles installed by others under NCDOT Project I-5504), with several wireless communications links;
- Upgrading and expanding the existing video monitoring system by replacing 5 existing analog CCTV cameras and their encoders with new digital equipment, adding 24 new digital camera locations (29 total locations), and modifying the existing central video equipment and database; and
- Replacing the existing closed-loop signal system software and central computers with new distributed processing software and new computer workstations and servers.

All of the existing NEMA controllers and cabinets are to be replaced with Model 2070E controllers in Type 332 or 336S cabinets under this project. Existing Model 2070L controllers and their Type 332/336S cabinets will be replaced with new Model 2070E controllers and new Type 332/336S cabinets (2012 NCDOT *Standard Specification* models).

In addition to signals in multiple existing closed-loop systems, there are several existing standalone (i.e., isolated) signals with either NEMA TS1 or Model 2070L controllers and cabinets that will be brought into the expanded signal system by extending new fiber-optic communications cable to these intersections and replacing the existing equipment with new Model 2070E controllers, Ethernet edge switches and controller cabinets.

New fiber-optic communications cable will be installed primarily by overlashing to the existing fiber-optic communications cable but also by lashing to new messenger cable, installing in existing underground conduit/duct systems, and installing in new underground conduit/duct systems. To migrate from the existing to the new communications system while minimizing disruptions to signal system operations, the existing fiber-optic communications system will be progressively decommissioned as the new Ethernet-based fiber-optic communications system is built-out and brought online.

Provide a complete, fully functional, and fully integrated traffic signal system, video surveillance system, and Ethernet communications system. Perform the following major tasks under this contract, as shown in the Plans (the list that follows is not meant to be all-inclusive):

◆ **Revision No. 1, April 10, 2017 – This document supersedes version originally issued and sealed by J. Todd Brooks, NCPE No. 017586 on 12/28/2016.**

U-4715B

ITS-18**Buncombe County**

- Furnish and install a new Ethernet-based fiber-optic communications system for the traffic signal system comprised of fiber-optic cable, fiber-optic drop cables, and fiber-optic splice centers (i.e., splice enclosures, interconnect centers, etc.), Ethernet switches and related electronics;
- Furnish and install underground conduit/duct, junction boxes, risers with heat shrink tubing, risers with weatherheads, messenger cable, fiber-optic cable storage guides, wood poles, and pole guy assemblies with guy guards;
- Furnish and install managed Ethernet core switch and Ethernet edge switches;
- Furnish and install new traffic signal controllers and cabinets with ancillary equipment, extending existing field wiring as necessary;
- Modify existing cabinet foundations and install new cabinet foundations;
- Upgrade existing traffic signal displays;
- Furnish and install integrated pushbutton accessible pedestrian signals (APS) at 4 locations;
- Remove existing control equipment and cabinets;
- Remove existing fiber-optic communications cable, including associated risers, splice cabinets and junction boxes, where designated in the Plans;
- Furnish and install detector loops, junction boxes, and lead-in cables;
- Furnish and install signal cable;
- Furnish and install CCTV camera assemblies and CCTV cabinets;
- Install Department-furnished metal CCTV poles at designated locations;
- Modify existing electrical services and install new electrical services and associated grounding;
- Fully integrate all components into a fully-functioning Ethernet-based, fiber-optic communications network;
- Fully integrate all traffic signal controllers, system detectors, software, computers and servers into a fully functioning distributed processing traffic control system; and
- Fully integrate all CCTV cameras, video components and software into a fully functioning video monitoring system.

Traffic signals and fiber-optic communications cable being installed by others under separate but concurrent NCDOT TIP and City road/intersection improvement contracts will ultimately be integrated into the new Asheville Signal System. These concurrent projects include but may not be limited to the following:

NCDOT TIP Projects:

- I-26/NC 191 (Brevard Road) Interchange Modifications and I-26 Widening/Reconstruction (I-5504)
- I-40 at US 25 (Hendersonville Road) Interchange Improvements (I-5885)
- I-40 at US 25A (Sweeten Creek Road) Interchange Improvements (I-5886)
- New Leicester Highway Sidewalk Construction (U-5190)

◆ **Revision No. 1, April 10, 2017 – This document supersedes version originally issued and sealed by J. Todd Brooks, NCPE No. 017586 on 12/28/2016.**

U-4715B

ITS-19

Buncombe County

City of Asheville Projects:

- River Arts District Transportation Improvement Project (RADTIP) (U-5019)

In addition to these NCDOT and City projects, there may be private developer projects constructed by others that modify existing or add new traffic signals and that include associated communications cable work. Possible concurrent private developer projects include but are not limited to the following intersections:

- Victoria Road at Lily Carmichael Drive/Livingstone Street (COA-15) - Signal Revision by Mission Hospitals.
- Airport Road at Loop Road – Planned New Signal.

While some of the traffic signal work on the above projects may be complete by the time construction begins on this signal system project, some work may still be ongoing when signal system construction begins. Contractors for different traffic signal projects who are working within the same area shall coordinate and cooperate with each other. Each contractor shall conduct his work so as not to interfere with or hinder the progress of the work being performed by the other contractors.

B. Specifications and Special Provisions

Conform to these Project Special Provisions and the North Carolina Department of Transportation (NCDOT) *Standard Specifications for Roads and Structures*, dated January 2012, hereinafter referred to as the “*Standard Specifications*.” Conform to the Codes and Regulations described in Section 1700 of the *Standard Specifications*.

Within these Project Special Provisions, the “Department” refers to the North Carolina Department of Transportation, and the “City” refers to the City of Asheville’s Transportation Department.

C. Coordination of Plans, Specifications, and Special Provisions

The *Standard Specifications*, the Plans and these Project Special Provisions are essential parts of the contract, and a requirement occurring in one is as binding as though occurring in all. They are complementary and provide and describe the complete contract. In case of a discrepancy or conflict, the following will apply in ascending order:

- Calculated dimensions shall govern over scaled dimensions;
- Supplemental Specifications shall govern over *Standard Specifications*;
- Plans shall govern over Supplemental Specifications, *Standard Specifications* and *Roadway Standard Drawings*;
- Project Special Provisions shall govern over Standard Special Provisions, Plans, *Standard Specifications*, Supplemental Specifications and *Roadway Standard Drawings*.

In the event of a contradiction within the Project Special Provisions as to the measurement and payment of any pay item, the text of the respective Measurement and Payment subsection for the pay item in question shall govern.

◆ **Revision No. 1, April 10, 2017 – This document supersedes version originally issued and sealed by J. Todd Brooks, NCPE No. 017586 on 12/28/2016.**

U-4715B**ITS-20****Buncombe County**

The Contractor shall not take advantage of any apparent error or omission in the contract. In the event such errors or omissions are discovered, the Engineer will make such corrections and interpretations as may be determined necessary for the fulfillment of the intent of the contract.

1.2. MATERIALS

A. Qualified Products

Furnish new equipment, materials, and hardware unless otherwise required. Inscribe manufacturer's name, model number, serial number, and any additional information needed for proper identification on each piece of equipment housed in a case or housing.

2012 ITS and Signals Qualified Products List (QPL) is available on the North Carolina Department of Transportation's website at the following address:

<https://connect.ncdot.gov/resources/safety/Pages/ITS-and-Signals-Qualified-Products.aspx>

Signal and communications equipment, material, and hardware shall be pre-approved on the QPL by the date of installation. Equipment, material, and hardware not pre-approved when required will not be allowed for use on the project. Consult the QPL website to obtain pre-approval procedures.

B. Submittal Requirements

Furnish a Type 3 material certification in accordance with Article 106-3 of the *Standard Specifications*. When requested by the Department, provide additional certifications from independent testing laboratories and sufficient data to verify item meets applicable specifications. Ensure additional certification states the testing laboratory is independent of the material manufacturer and neither the laboratory nor the manufacturer has a vested interest in the other.

Identify all proprietary parts in Contractor-furnished material. The Department reserves the right to reject material that uses proprietary components not commercially available through electronic or electrical supply houses.

For Contractor-furnished material listed on the QPL, furnish submittals in the format defined by the QPL.

For Contractor-furnished material not on the QPL, furnish three copies of the equipment list including three copies of catalog cuts. Identify proposed material on catalog cuts by a reproducible means (highlighter pen does not transfer to copies). Ensure material lists contain material description, brand name, manufacturer's address and telephone number, stock number, size, identifying trademark or symbol, and other appropriate ratings.

Do not fabricate or order material until receipt of the Engineer's approval.

Refer to the "Submittal Data and Documentation" section of these Project Special Provisions for additional submittal requirements.

C. Observation Period

Prior to final acceptance, all Contractor-furnished equipment and software shall successfully complete a 60-day Observation Period.

The 60-day Observation Period is considered to be part of the work included in the total contract time and must be completed prior to final acceptance of the project.

◆ **Revision No. 1, April 10, 2017 – This document supersedes version originally issued and sealed by J. Todd Brooks, NCPE No. 017586 on 12/28/2016.**

U-4715B**ITS-21****Buncombe County**

Final acceptance will occur following the successful completion of the 60-day Observation Period and after all documentation requirements have been fully satisfied.

Refer to the "Testing and Acceptance" section of these Project Special Provisions for additional requirements.

D. Warranties

Unless otherwise required herein, provide manufacturer's warranties on Contractor-furnished equipment for material and workmanship that are customarily issued by the equipment manufacturer or that are at least one year in length, whichever is greater, from the date of final acceptance of the project by the Department. Include unconditional coverage for all parts and labor necessary or incidental to repair of defective equipment or workmanship and malfunctions that arise during warranty period.

For light emitting diode (LED) traffic signal modules, provide a written warranty against defects in materials and workmanship for a period of 60 months after installation of the modules. During the warranty period, the manufacturer must provide replacement modules within 45 days of receipt of modules that have failed at no cost to the Department.

Ensure all Contractor-furnished equipment, including pieces and components of equipment, hardware, firmware, software, middleware, internal components, and subroutines which perform any date or time data recognition function, calculation, or sequencing will support a four digit year format for a period of at least 50 years and will support user-definable parameters for setting the start and end dates for daylight savings time.

Upon receipt of the Department's written final acceptance of project, transfer manufacturer's warranties with proper validation by the manufacturer to the Department and the City. Provide warranties in the names of both the North Carolina Department of Transportation and the City of Asheville.

E. Firmware Licensing and Upgrades

Provide the Department with a license to duplicate all programmable devices in equipment for maintenance and software upgrades. Provide binary or hexadecimal format files for each device that may be programmed by the Department. Ensure files are provided on PC compatible compact disks or other approved media.

Ensure software/firmware performance upgrades that occur during the contract period up through final acceptance of the project are furnished to the Department at no additional cost.

Make software/firmware upgrades that are developed to correct operating characteristics available to the Department at no additional cost until the warranty period expires.

Provide licensed copies of all software/firmware to the Department for any programmable devices furnished by the Contractor and installed under this project for which licensed software has not already been provided by the City and the Department. The Department shall have the right to install any and all software/firmware for maintenance and support on all hardware provided under this contract. This shall include but not be limited to all servers for the Signal System, CCTV System, LAN System, traffic signal controllers and network. Provide software/firmware for maintenance and support of workstations, laptop computers, system support software, utility software, traffic signal controllers, and CCTV systems and controllers, and all other programmable devices.

◆ **Revision No. 1, April 10, 2017 – This document supersedes version originally issued and sealed by J. Todd Brooks, NCPE No. 017586 on 12/28/2016.**

U-4715B**ITS-22****Buncombe County****F. Wire and Cable**

Furnish wire and cable on reels. When requested by the Department, furnish samples of wire and cable to the Department at no additional cost.

Provide either 0.05" x 0.30" aluminum wrapping tape or 0.06" stainless steel lashing wire for lashing cables to messenger cable. Use 0.045" stainless steel lashing wire to lash fiber-optic communications cable to messenger cable.

G. Painting

Where painting of signal heads, signal poles, and pedestals is required, apply paint at the factory. No field painting will be allowed except when paint has been scratched or marred. In such cases, apply two field coats of the same color and grade enamel as the original paint to the scratched or marred portions. For the aforementioned unfinished components that require field painting, prepare the surface to receive the paint in accordance with the coating manufacturer's instructions, including application of primer.

H. Performance of Warranty Repair and Maintenance

Provide authorization to the Traffic Electronics Center of the North Carolina Department of Transportation (NCDOT) to perform all warranty repairs after project acceptance. The decision to perform warranty work at the Traffic Electronics Center by NCDOT electronics technicians or to have warranty work performed by the vendor shall be at the discretion of the Department. Provide any training required by the manufacturer to authorize the Traffic Electronics Center to perform warranty work and ensure manufacturer will furnish parts to the Traffic Electronics Center for all warranty repairs at no cost to the Department. In addition, ensure the manufacturer agrees to provide prompt technical support to the NCDOT electronics technicians for a period of one year after the end of the warranty period at no cost to the Department. Defective parts replaced under warranty by the Traffic Electronics Center will be returned to the vendor at the vendor's request. Provide schematics, part lists, and other documentation to perform bench repair to the Traffic Electronics Center within 2 weeks upon request. The Department agrees not to divulge any proprietary information in the schematics, part lists and other documentation upon request from the vendor. After project acceptance and at the request of the Department, the manufacturer shall perform warranty repairs to equipment which fails during the warranty period at no cost to the Department including freight costs to ship repaired equipment back to the Traffic Electronics Center. Ensure all equipment is repaired and returned to the Traffic Electronics Center within 21 calendar days of receipt by the manufacturer.

1.3. CONSTRUCTION METHODS**A. General**

Before beginning signal work, verify all existing signal equipment is in satisfactory working order. Report all defective signal equipment to the Engineer so as not to be held responsible for defects.

Identify and label all field wiring (e.g., signal conductors, pushbutton wires, loop detector lead-ins, etc.) in existing controller cabinets prior to disconnecting any field wiring.

Do not remove and replace more than one controller and cabinet per day unless otherwise approved by the Engineer. Once controller and cabinet replacement has begun at a given

◆ **Revision No. 1, April 10, 2017 – This document supersedes version originally issued and sealed by J. Todd Brooks, NCPE No. 017586 on 12/28/2016.**

U-4715B**ITS-23****Buncombe County**

location, complete the removal and replacement work at that location before beginning removal and replacement of a controller and cabinet at another location.

Locate existing conduit, cable runs, inductive detection loops, lead-in, junction boxes, and detection equipment before installing or using equipment that can damage or interfere with such facilities. The locations of existing inductive detection loops shown on the Plans are approximate.

Locate all underground utilities before beginning drilling, digging, and trenching operations.

Ensure that an IMSA certified, or equivalent, Level II traffic qualified signal technician is standing by to provide emergency maintenance services whenever work is being performed on traffic signal controller cabinets and traffic signal controller cabinet foundations. Standby status is defined as being able to arrive, fully equipped, at the work site within 30 minutes ready to provide maintenance services.

Immediately cease work and notify the Engineer and affected owners if damage to existing utilities, cables, or equipment occurs. Make all required repairs and replacements at no additional cost to the Department.

Avoid trimming (i.e., pruning) trees wherever possible. Removal and topping of trees is strictly prohibited. Contact Mark Foster, the City's Arborist at (828) 259-5979 to obtain approval from the Asheville Tree Commission for any proposed tree trimming and pruning prior to performing tree trimming. Comply with Chapter 20, "Trees", of the City of Asheville Code of Ordinances, which may be found online at:

https://www.municode.com/library/nc/asheville/codes/code_of_ordinances

All tree trimming must be performed by an ISA Certified Arborist Trimming and must conform to ANSI A300 standards. In addition, the Contractor must obtain a Minor Work Certificate of Appropriateness from the Historic Resources Commission for any tree trimming or pruning in and around historic districts and historic resources (contact Alex Cole, Historic Resources Specialist for City of Asheville, for information on historic districts). The Contractor will be assessed civil penalties (i.e., fines) for any tree trimming performed in violation of the requirements of the Project Special Provisions and the City's Code Ordinances, including but not limited to work performed by someone other than an ISA Certified Arborist, unauthorized tree trimming, failure to obtain required permit and approvals, excessive tree trimming and tree removal.

B. Contractor's Office

Throughout the project until final acceptance, the Contractor shall maintain a full-time staffed office with storage and testing facilities within the Asheville City Limits.

C. Work within Historic Districts

Several signalized intersections, some proposed CCTV camera sites and several fiber-optic communications cable routes lie within or adjacent to historic districts. The Department has coordinated with the agencies that have jurisdiction over these historic districts and has received the permits and certificates for the work called for in the Plans in these historic districts. Do not deviate from the work called for in the Plans within a historic district without the prior approval of the Engineer and the agency/agencies that have jurisdiction over the historic district. Where construction work must deviate from the Plans, notify the Engineer in advance so that the

◆ **Revision No. 1, April 10, 2017 – This document supersedes version originally issued and sealed by J. Todd Brooks, NCPE No. 017586 on 12/28/2016.**

U-4715B

ITS-24

Buncombe County

Department can request/apply for the appropriate approvals for such changes prior to the Contractor performing work at that location.

Avoid damaging or removing sidewalks and curbs within designated historic districts whenever possible. Do not damage, disturb or remove any existing granite curbs. Where granite curbs conflict with the installation of underground conduit and cable, bore (drill) conduit underneath granite curb. Do not bore through granite curbs. Replace any granite curb damaged due to construction of this project at no cost to the Department or the City. Immediately notify the Engineer and coordinate with Chad Bandy, PE, City of Asheville Streets Manager, by phone at 828-259-5431 and in writing via email at cbandy@ashevillenc.gov, if any existing granite curb is disturbed or damaged by construction of this project. As directed by the Engineer, reset disturbed granite curb and replace damaged granite curb in accordance with the “Existing Granite Curb” subsection below.

Where removal and replacement of concrete sidewalk and concrete curb is unavoidable, removal and replacement shall be in accordance with “Utility Cuts within City Maintained Street Right of Way, page 5-6 of the *City of Asheville Standard and Specifications and Details Manual*. To obtain the required right-of-way disturbance permit for such work, contact Alisa McLaughlin at 828-259-5406 or amclaughlin@ashevillenc.gov. Replace them with concrete materials that match the finish, appearance and color of the adjacent existing sidewalk as close as technically feasible as determined by the Engineer. Any concrete sidewalk that is removed and replaced in the Central Business District shall be replaced with the Asheville Running Bond patterns found in Detail 3.16B of the *City of Asheville Standard and Specifications and Details Manual*. Finishes may include but are not limited to water-washed, broom and trowel. The dimensions and the profile (i.e., shape) of the new curbing shall match that of the adjacent existing curbing.

Where removal and replacement of sidewalk constructed of materials other than concrete is unavoidable, notify the Engineer and coordinate with the Chad Bandy, PE, City of Asheville Streets Manager, at 828-259-5431 at least two weeks prior to disturbing the existing sidewalk. Replace the sidewalk with in-kind materials that match the finish, appearance and color of the adjacent existing sidewalk as close as technically feasible as determined by the Engineer and the City’s Streets Manager. If the sidewalk is constructed of materials such as brick, stone or pavers, carefully remove and subsequently reinstall the bricks, stones or pavers using methods approved by the Engineer. If bricks, stones or pavers are broken, contact Chad Bandy for appropriateness of replacement materials. Take photographs and make sketches to record the pattern of the existing materials prior to removal. Replace any bricks, stones or pavers damaged due to construction on this project with approved in-kind, matching materials.

Repair and replacement of existing sidewalk will be measured and paid for in accordance with the “Equipment Cabinet Foundations” section of these Project Special Provisions.

Complete all repairs with in-kind materials to all sidewalks removed for construction and reopen the repaired and restored sidewalk to pedestrian traffic within five consecutive calendar days following initial removal. If the Contractor fails to repair and reopen a sidewalk in accordance with these Project Special Provisions within the time frame specified, the Department reserves the right to make the necessary repairs, and all expenses incurred by the Department in making the repairs and restoring the sidewalk will be deducted from payment due the Contractor, plus **\$500 liquidated damage per occasion, per day, or any portion thereof,** until corrected.

◆ **Revision No. 1, April 10, 2017 – This document supersedes version originally issued and sealed by J. Todd Brooks, NCPE No. 017586 on 12/28/2016.**

For new signal cabinet foundations constructed within historic districts, use concrete tinted to light earth-toned palette to soften the visual impact of the new concrete.

Do not trim, remove or damage tree limbs within historic districts. Hand-lashing of aerial cables to messenger cable may be required in some areas due to overhanging and protruding tree limbs along the cable route.

D. Existing Granite Curb

Replace any granite curb damaged due to construction of this project at no cost to the Department or the City. Immediately notify the Engineer and coordinate with the Chad Bandy, PE, City of Asheville Streets Manager, at 828-259-5431, when any existing granite curb is disturbed or damaged by construction of this project. As directed by the Engineer, reset disturbed granite curb and replace damaged granite curb in accordance with the following City of Asheville requirements:

1. All granite curb work shall be in compliance with Detail 3.11D of the *City of Asheville Standard and Specifications and Details Manual*.
2. Exercise care to remove, store, and resetting granite curb without breaking.
3. During removing and resetting granite curb, use belt slings or slab tongs. Exercise due care to ensure no chipping, breakage or other damage occurs during this process.
4. Prior to removing the granite curb, saw-cut the pavement to full depth for a minimum distance of 6" from the face of the curb for the full length of the curb section being removed.
5. If a concrete or granite gutter exists, remove and reinstall the gutter after the granite curb is reinstalled.
6. Where the granite curb returns into an adjacent street, project the saw cuts on the designated lines to a point where both cuts intersect, unless the Engineer directs otherwise.
7. Excavate the area to required grade.
8. Reset the granite curb so that the top of reset curb aligns with the top of the abutting curb at each end of the reset block and is approximately 6" above the existing asphalt.
9. Reset granite curb on a bed of dry mix 3000 psi concrete (compressive strength of 3000 psi in 28 days), conforming to ASTM M 157-97.
10. Provide a continuous concrete bed that is 12" wide and 4" deep.
11. Before resetting granite curb, install a string line true to the vertical and horizontal alignment.
12. Reset granite curb to new grade.
13. The maximum gap between blocks should be 1/8".
14. After resetting the granite curb to line and grade, fill the widened area with 3000 psi concrete.
15. Place concrete to a depth of 1.5" below final pavement grade (asphalt pavement), or to finished gutter grade. Place 3000 psi concrete at each joint.
16. Place concrete to a depth of approximately 10", to a width of 6" (3" either side of the joint) and to a thickness of 6".

◆ **Revision No. 1, April 10, 2017 – This document supersedes version originally issued and sealed by J. Todd Brooks, NCPE No. 017586 on 12/28/2016.**

U-4715B**ITS-26****Buncombe County**

17. Do not place concrete within 4" of the top of the granite curb.

E. Work within the Special Business Districts

There are three commercial business districts in Asheville that feature a high concentration of restaurants, retail stores, offices, governmental offices and community services providers, that have on-street parking lining most curbs, and that have an extensive sidewalk network. These areas routinely experience concentrated volumes of vehicular and pedestrian traffic and on-street parking during business hours on weekdays as well as on weekends. Business hours in these areas extend into nighttime. The three special business districts are described as follows:

1. The **Central Business District (CBD)** in downtown Asheville, which for the purpose of this project is defined as the area in downtown Asheville bounded by I-240, Clingman Avenue, Hilliard Avenue, Biltmore Avenue, Charlotte Street inclusive.
2. **Biltmore Village** south of downtown Asheville which for the purpose of this project is defined as the area bounded by All Souls Crescent, Lodge Street and Brook Street inclusive.
3. **West Asheville Business District** west of downtown Asheville which for the purpose of this project is defined as the section of Haywood Road from Oakwood Street to Ridgelawn Road.

Do not perform any work within the boundaries of these special business districts, including along the boundary streets, without prior approval of the Department and the City. Submit to the Department and City for review and approval two weeks in advance a schedule for proposed work that will require narrowing or closing a lane, road, sidewalk or pedestrian crossing within these areas.

F. Special Pedestrian Considerations around A-B Tech Campus

The streets and sidewalks around the A-B Tech (Asheville-Buncombe Technical Community College) campus are subject to high levels of pedestrian and bicycle activity when school is in session. Preserving pedestrian and bicycle mobility, including maintaining access to ART bus stops, in these areas may require special, additional measures. Submit to the Department and City for review and approval two weeks in advance a schedule for proposed work that will require narrowing or closing a lane, road, sidewalk or pedestrian crossing along Victoria Road between Lily Carmichael Drive and Fernihurst Drive.

G. Regulations and Codes

Furnish material and workmanship conforming to the *National Electric Code* (NEC), *National Electric Safety Code* (NESC), Underwriters Laboratories (UL), or other listing agencies approved by the North Carolina Department of Insurance, and all local safety codes in effect on the date of advertisement. Comply with Article 4, Chapter 87 of the *North Carolina General Statutes* (Licensing of Electrical Contractors). Comply with the Plans, all previously referenced specifications, and all applicable local ordinances and regulations before and during all stages of the electrical work.

When required by the local ordinances and governmental agencies, upon completion of the work, have all systems inspected and approved in writing by the authorized governmental electrical inspector for the area. Furnish written certification of the authorized inspector's approval to the Engineer. Inspection by the authorized governmental electrical inspector must

◆ **Revision No. 1, April 10, 2017 – This document supersedes version originally issued and sealed by J. Todd Brooks, NCPE No. 017586 on 12/28/2016.**

U-4715B**ITS-27****Buncombe County**

neither eliminate nor take the place of the inspections by the Engineer. Upon the Engineer's receipt of written certification and the Contractor's written request for a final inspection of the installations, the Engineer will perform a final inspection.

Where required, conform to ITE, AASHTO, and ASTM standards in effect on the date of advertisement.

Notify the Engineer, local traffic enforcement agency, local utility company, and affected railroad companies seven business days before operational shutdowns to coordinate connection or disconnection to an existing utility or system, unless otherwise instructed herein.

Install meter bases and service disconnects as required by the NESC, NEC, local utility companies, and local ordinances. Install standoffs only when required and approved by the local utility companies. Where a standoff must be used, obtain the local utility company's approval prior to installing the standoff.

H. Utility Services

Coordinate all work to ensure electrical power of proper voltage, phase, frequency, and ampacity is available to complete the work. Use electrical service cables with THWN insulation.

When electrical, telephone, and telecommunication service is not furnished by the Department or the City and is required, contact the utility company and make application to ensure all work can be completed. Obtain authorization for service in the Department's name for Department-owned locations and in the City's name for City-owned locations. Make application for service in the Department's name for Department-owned locations and in the City's name for City-owned locations.

The Department and the City will be responsible for direct payment of monthly utility company usage charges. The Contractor will be responsible for all expenses associated with utility installation costs, hookups, etc.

Coordinate all work involving electrical service with the appropriate electric utility company. Coordinate with the utility company to ascertain the feasibility of installing electrical service at each location before performing any work. Obtain all required local permits before beginning work.

I. Maintenance and Repair of Material

Ensure that an IMSA certified, or equivalent, Level II traffic qualified signal technician is standing by to provide emergency maintenance services whenever work is being performed on traffic signal controller cabinets and traffic signal controller cabinet foundations. Standby status is defined as being able to arrive, fully equipped, at the work site within 30 minutes ready to provide maintenance services.

Furnish the Engineer with the name, office telephone number, cellular (mobile) telephone number, and pager number of the supervisory employee who will be responsible for maintenance and repair of equipment during all hours.

Maintain and repair all Contractor-furnished and installed signal and communications related equipment within the project construction limits until completion of the Observation Period and receipt of written notification of final acceptance of the project. This requirement for maintaining and repairing said equipment shall remain in effect in the event of severe weather

◆ **Revision No. 1, April 10, 2017 – This document supersedes version originally issued and sealed by J. Todd Brooks, NCPE No. 017586 on 12/28/2016.**

U-4715B

ITS-28

Buncombe County

(see NOAA National Severe Storms Laboratory website <http://www.nssl.noaa.gov/primer/>) or a natural disaster, including but not limited to floods, winter weather, lightning, damaging winds, hail, tornado, tropical storm or hurricane. Items reused (that are unmodified), such as signal heads, signal cable, local detector loops and lead-in cable, will be maintained by others.

Make entries into the maintenance diaries housed inside each traffic signal controller cabinet upon each visit to the controller cabinet. Maintain these diaries through final acceptance of the project.

For all failures, malfunctions, damages to equipment, or errors in workmanship affecting signal operation, begin necessary repairs within 4 hours of notification. Complete repairs within 8 hours of notification. Comply with Section 150 of the *Standard Specifications* for maintenance of traffic flow. The inability to contact the supervisory employee or prearranged alternate will not extend repair time requirements.

Remove and replace all signal and communications related equipment that fails. The Department will furnish the Contractor replacement equipment for Department-furnished equipment that fails, except for equipment furnished by other contractors within the construction limits of separate NCDOT TIP projects and City of Asheville projects that have not yet been formally accepted by the Department. Maintenance and repair of equipment within the construction limits of NCDOT TIP projects will be the responsibility of the respective TIP project contractors until the Department's final acceptance of those TIP projects.

Except for damages and malfunctions caused by the Contractor's work activities, the Contractor will not be held responsible for pre-existing conditions reported to the Engineer before starting traffic signal work at the specific intersection. The Contractor will assume responsibility for all maintenance and emergency services necessary once traffic signal work has begun at the specific intersection and for all damages and malfunctions caused either directly or indirectly by the Contractor's work activities.

Perform maintenance (testing) on all traffic signal conflict monitors every 12 months for the life of the project beginning with the initial test and every 12 months thereafter. Provide initial test date via the manufacturer's certification or via testing prior to installation of the conflict monitor at an intersection. Use ATSI Incorporated Model PCMT-2000 Conflict Monitor Tester or an Engineer approved equivalent. Use a signal conflict monitor tester that is capable of interfacing with an Intel[®]-based notebook computer for input/output. The tester shall test signal conflict monitor displays, timing and voltage functions, and input/output combinations of either true or false conflicts. All outputs shall be in plain English. It shall be possible to generate a hard copy printout or to store the results to a file on computer disc. A "No Faults Detected" indication shall be displayed as appropriate.

Ensure that the signal conflict monitor tester is maintained and calibrated per the manufacturer's recommendation. Provide to the Engineer a copy of the manufacturer's certification that the signal conflict monitor tester is in proper working order before testing any traffic signal conflict monitors. Perform test on each traffic signal conflict monitor per the manufacturer's recommendation. For each traffic signal conflict monitor tested, provide two (2) dated copies of the traffic signal conflict monitor test results: one copy for the Engineer and one copy placed in the traffic signal controller cabinet.

◆ **Revision No. 1, April 10, 2017 – This document supersedes version originally issued and sealed by J. Todd Brooks, NCPE No. 017586 on 12/28/2016.**

U-4715B

ITS-29

Buncombe County

In the event the Contractor fails to perform in accordance with the Plans and Project Special Provisions within the time frame specified, the Department reserves the right to perform maintenance and emergency service necessary to ensure continuous traffic signal operation. Further, all expenses incurred by the Department in implementing this option will be deducted from payment due the Contractor, plus **\$2,500 liquidated damages per occasion, per day, or any portion thereof**, until corrected.

J. Inspections

The City and the Department may access the Contractor's equipment to perform railroad, signal, and preventative maintenance inspections, and conflict monitor certification as necessary. The Contractor shall be present for these inspections.

K. Removal of Existing Equipment and Material

Remove all Department-owned and City-owned signal, CCTV and communications related equipment and material that will not be used. Signal, CCTV and communications equipment and materials to be removed under this project include, but are not limited to: signal controllers and cabinets and the equipment housed therein; signal and lead-in cables; CCTV cameras and mounting brackets; CCTV cabinets and equipment housed therein; poles; splice cabinets; cabinet foundations; junction boxes; messenger cable; communications cable; and guy assemblies.

Assume ownership of removed poles (including stub poles), messenger cable, junction boxes, interconnect cable, communications cable, and supporting hardware. Return all other Department-owned and City-owned equipment and material as follows:

- Return Department-owned equipment removed from locations in both Buncombe and Henderson Counties between 7:30 a.m. and 2:30 p.m., Monday through Thursday, to the Division 13 Traffic Signal Shop (warehouse) at the Traffic Services office, located at 11 Old Charlotte Highway in Asheville, North Carolina, 28803, or at a time mutually agreed to by the Contractor, the Engineer and the Division 13 Traffic Signal Supervisor. Contact the Division 13 Electronics Technician Supervisor at (828) 298-0094 in advance of each delivery to schedule a mutually agreed up day and time for delivery of removed materials and equipment.
- Return all other City-owned equipment and material between 8:00 a.m. and 12:00 p.m., Monday through Thursday, to the City of Asheville Signal Shop located at 161 South Charlotte Street in Asheville (28801), or at a time mutually agreed to by the Contractor, the Engineer and the City. Contact Dean Grayson of the City at (828) 259-5449 in advance of each delivery to schedule a mutually agreed up day and time for delivery of removed materials and equipment.

Label all returned equipment and material to indicate the location from which it was removed. Replace or repair all material lost or damaged during its removal and transit. The Department will deduct the cost of Department-owned and City-owned equipment damaged by the Contractor from money due to the Contractor.

L. Railroad Preemption

Where railroad preemption is required, coordinate all work with the railroad. Do not place signals into operation until signal and railroad company equipment has been interconnected with required railroad-highway crossing devices and railroad preemption is working properly. Ensure

◆ **Revision No. 1, April 10, 2017 – This document supersedes version originally issued and sealed by J. Todd Brooks, NCPE No. 017586 on 12/28/2016.**

U-4715B**ITS-30****Buncombe County**

preemption sequences begin immediately after activation of train detection. Contact and coordinate with the railroad company to schedule interconnection of the signal to the railroad controller cabinet. Install lead-in cable from the signal controller cabinet to a railroad company furnished and installed lockable junction box. Interconnection will be made by the railroad company. Provide fail-safe operation such that removal of voltage from the railroad side of the isolation relay will initiate the railroad preemption sequence.

Conduct a railroad-highway interconnection preemption inspection for each intersection prior to placing new signal equipment into steady operation. The inspection shall be performed with all appropriate Division, City and Railroad personnel in attendance. The signal shall pass all requirements of the preemption inspection before it can be accepted under the project by the Engineer. The railroad preemption inspection form is available on the NCDOT ITS & Signals Unit website:

<https://connect.ncdot.gov/resources/safety/Pages/ITS-and-Signals.aspx>

The Contractor, along with other appropriate personnel, shall conduct additional preemption inspections annually as long as the signal is in operation under the Contractor's jurisdiction until the signal is accepted by the Engineer.

M. Timing of Signals

The Contractor shall utilize experienced signal timing personnel to revise existing timings and to implement new timing values.

Modify proposed phasing and timing of existing controllers to accommodate all changes which result from installation of new equipment under this project. Convert and reinstall all existing time-of-day plans, including revisions to offset references from NEMA-type equipment, to function and operate in newly installed 2070E equipment. Coordinate timing work with Department staff and City staff for converting the existing offset references to new offset references. The Contractor will be responsible for installing the revised offset references once developed through coordination with and with approval of Department staff and City staff.

Submit requests for intersection timing parameters and data to the Engineer at least three weeks (15 business days) prior to needing them. The Department and City will provide existing intersection and system timing parameters (cycle, split and offset) and available custom graphics. Department and City-supplied intersection and system timing parameters, databases and timing plans will be provided in MS Excel format electronically as portable document format (PDF) files only.

The Contractor shall be responsible for converting Department-furnished and City-furnished timing data to OASIS™-formatted data and for loading all timing data into the controllers and conflict monitors. Submit the converted data files for review and approval by the Department and the City at least two weeks (10 business days) prior to scheduled implementation. The Department and the City will supply the signal timing parameters (cycle, split and offset) and available custom graphics for any signal requiring phasing changes.

The Department reserves the right to make, or have the Contractor make, field timing adjustments and modifications to coordination and offsets to account for changes in signal phasing and equipment operations necessary for pattern optimization and to eliminate identifiable, potential hazards to the motoring public. The Engineer will notify the Contractor of

◆ **Revision No. 1, April 10, 2017 – This document supersedes version originally issued and sealed by J. Todd Brooks, NCPE No. 017586 on 12/28/2016.**

U-4715B**ITS-31****Buncombe County**

timing changes made or supply the Contractor with revised timing plans if the Department requires the Contractor to implement the timing changes.

N. Wire and Cable

For installation in a conduit system, lubricate cable and wires before installing in conduit. Use lubricant that will not physically or chemically harm cable jacket, wire insulation, and conduit.

Only splice lead-in cables in junction boxes using UL[®]-approved, underground splice connectors or in condulets using gel-filled splice connectors. Splice all other electrical wire and cable (i.e., signal cable, etc.) inside equipment cabinets, cabinet base extenders/adapters, and terminal splice boxes at nickel-plated brass, recessed-screw, barrier-type terminal blocks or using gel-filled splice connectors. Unless specifically allowed, connect no more than two conductors to the same terminal screw. Do not splice any electrical wire or cable other than lead-in cables in junction boxes or condulets.

Maintain color coding of wires through splices.

Protect ends of wire and cable from water and moisture.

Place permanent labels on all wires and cables to clearly identify each one. Use an indelible black ink marker or approved labeling devices to write on the permanent labels when required.

Install all wire and cable with necessary hardware including, but not limited to shoulder eyebolts, washers, nuts, thimbleyelets, three-bolt clamps, J-hooks, split bolt connectors, grounding clamps, and lashing material.

O. Electrical Services and Grounding

Where electrical services do not include an external electrical service disconnect, modify or replace the electrical service to add an electrical service disconnect and a new grounding electrode system. Comply with the "Electrical Service" section of these Project Special Provisions.

Provide a grounding electrode system at all new electrical services. In addition to NEC requirements, test grounding electrode resistance for a maximum of 20 ohms. Furnish and install additional ground rods to grounding electrode system as necessary to meet test requirements.

Modify existing electrical services, as necessary, to meet the grounding requirements of the NEC, these Project Special Provisions and the Plans. Remove any ground rods in the cabinet foundation and install a new grounding electrode system. Cut off abandoned ground rods in the cabinet foundation flush with the foundation surface. Where a grounding electrode system is connected to the electrical service in accordance with the NEC, test grounding electrode resistance for a maximum of 20 ohms. Grounding electrode resistance test must be verified or witnessed by the Engineer or the Engineer's designated representative. Furnish and install additional ground rods to grounding electrode system as necessary to meet the Project Special Provisions and test requirements. Refer to the "Electrical Service" section of these Project Special Provisions for additional requirements pertaining to grounding of electrical services.

Follow test equipment's procedures for measuring grounding electrode resistance. When using clamp-type ground resistance meters, readings of less than 1 ohm typically indicate a ground loop. Rework bonding and grounding circuits as necessary to remove ground loop

◆ **Revision No. 1, April 10, 2017 – This document supersedes version originally issued and sealed by J. Todd Brooks, NCPE No. 017586 on 12/28/2016.**

U-4715B**ITS-32****Buncombe County**

circuits and retest. If a ground loop cannot be identified and removed to allow the proper use of a clamp-type ground resistance meter, use the three-point test method.

Submit a completed Inductive Loop & Grounding Test Form available on the Department's website. The form is located on the Department's website at:

<https://connect.ncdot.gov/resources/safety/Pages/ITS-and-Signals.aspx>

Provide a length of marker tape 6 to 12 inches below finished grade directly over grounding electrodes and conductors.

P. Electrical Bonding

Using an approved termination means, connect a number 14 AWG minimum 19-strand copper conductor (Type THWN) with green insulation to serve as an equipment grounding conductor to metal poles, vehicular and pedestrian signal pedestals, and other metallic components which are not otherwise bonded, through means approved by the Engineer.

Q. Traffic Signal Activation

Do not place signal in steady (stop-and-go) mode until inspected and authorized by the Engineer.

R. Requirements for Cables Crossing Railroads

Copies of all executed railroad agreements and related correspondence may be obtained from the Engineer upon request.

1. Railroad Crossings

Application has been made with Norfolk Southern Corporation (NS), and Blue Ridge Southern (BLU) herein called the Railroad Company(ies), for the encroachment agreements necessary under this Contract. Do not commence cable routings over or under railroad-owned facilities until notification and coordination with Engineer and the appropriate Railroad Company has occurred. Install fiber-optic communications cable as shown on the Plans. All work associated with the crossing is to conform to the Railroad Company's specifications.

For work within NS rights of way, comply with latest approved edition of NCSE-4 (Specifications for Wire, Conduit and Cable Occupations of Norfolk Southern Corporation Property) and NSCE-8 (Specifications for Pipeline Occupancy of Norfolk Southern Corporation Property).

For work within BLU rights of way, comply with the latest approved edition of Railroad Specification CE-4, "Specifications for Wire, Conduit and Cable Occupations of Railroad Property" and Railroad Specification CE-8 "Specifications for Pipeline Occupancy of Railroad Property."

◆ **Revision No. 1, April 10, 2017 – This document supersedes version originally issued and sealed by J. Todd Brooks, NCPE No. 017586 on 12/28/2016.**

U-4715B

ITS-33

Buncombe County

Cable crossings include the following locations:

| Plan Sheet | Location | Railroad Company |
|------------|--|------------------|
| CRP-6.047 | At-Grade Crossing across Biltmore Avenue near Lodge Street/ Crossing # 720 475E | NS |
| CRP-6.274 | At-Grade Crossing across Craven Street near Riverside Drive / Crossing # 720 408K | NS |
| CRP-6.294 | At-Grade Crossing across Louisiana Avenue near Emma Road / Crossing # 720 402U | BLU |
| CRP-6.256 | RR Underpass at New Leicester Highway near Oak Hill Dr/ Crossing # 720 400F | BLU |
| CRP-6.154 | At-Grade Crossing across Bear Creek Road near Patton Avenue / Crossing # 720 397A | BLU |
| CRP-6.149 | RR Underpass at Smokey Park Highway between Cooper Blvd and Lowes Entrance/ Crossing # 720 393X | BLU |
| CRP-6.233 | RR Underpass at Sand Hill Road near Smokey Park Highway / Crossing # 720 387U | BLU |
| CRP-6.210 | RR Overpass at Sweeten Creek Road near West Chapel Road/ Crossing # 720 623W | BLU |
| CRP-6.213 | At-Grade Crossing across Crayton Road / Crossing # 720 620B | BLU |
| CRP-6.217 | RR Underpass at Fairview Road near I-240 Ramps / Crossing # 951 137U | NS |
| CRP-6.222 | RR Overpass at US 74 Alt Westbound near I-40 / Crossing #720 749D | NS |
| CRP-6.271 | At-Grade crossing across Mills Gap Road between Sweeten Creek Road and Hendersonville Road / Crossing # 720 630G | BLU |
| CRP-6.023 | RR Overpass at Hendersonville Road near Linamar Entrance / Crossing # 720 632V | BLU |
| CRP-6.145 | RR Underpass at Monte Vista Road near Smokey Park Highway / Crossing # 720 390C | BLU |
| CRP-6.206 | RR Underpass at Porters Cove Road between I-40 and Tunnel Road / Crossing # 720 752L | NS |

2. Insurance Requirements

The Department has provided Railroad Protective Liability Insurance to the railroad companies as part of the Department's encroachment agreements with the railroad companies for each of location listed in the table above.

If required by the railroad, pay for railroad personnel to be present when work is performed.

In addition to any other forms of insurance or bonds required under the terms of the Contract and the *Standard Specifications*, take out and keep in force from the commencement of all construction on railroad right-of-way until the final inspection and acceptance of the project by the Engineer, insurance of the following kinds and amount. It is understood that the amounts specified are minimum amounts and that larger amounts may be carried if so desired. Any

◆ **Revision No. 1, April 10, 2017 – This document supersedes version originally issued and sealed by J. Todd Brooks, NCPE No. 017586 on 12/28/2016.**

U-4715B**ITS-34****Buncombe County**

insurance taken out due to these requirements shall be subject to the approval of the Engineer, and the Railroad Companies as to form and amount. Furnish satisfactory policies prior to beginning of the work on railroad right-of-way.

Refer to the following web links for more specific insurance requirements and requirements for working on the rights-of-way of each railroad company. In the event of a conflict between the requirements of one or more railroad companies and the requirements contained in the Plans or these Project Special Provisions, the requirements of the railroad company shall govern.

Norfolk Southern Corporation:

<http://www.nscorp.com/content/nscorp/en/real-estate/customer-resources.html>

Blue Ridge Southern Railroad:

<https://www.watcocompanies.com/customer-tools/permitting/>

Commercial General Liability Insurance

Furnish evidence to the Engineer of Contractor's commercial General Liability Insurance coverage with a combined single limit of not less than \$5,000,000 for each occurrence for operations performed on the railroad right-of-way. The Contractor's policy shall name the railroad company(ies) as an additional insured. If any part of the work is sublet, similar insurance in the same amounts and evidence thereof as required of the Prime Contractor shall be provided by or on behalf of the Subcontractor to cover Subcontractor's operations on the railroad right-of-way.

Keep such insurance in force until final inspection of the project, or that portion or portions within the railroad right-of-way, by the Engineer or, in the case of Subcontractors, until the Contractor furnishes a letter to the Engineer stating that the Subcontractor has completed his/her subcontracted work within the railroad right-of-way to Contractor's satisfaction, and that the Contractor will accomplish any additional work necessary on the railroad right-of-way with the Contractor's own forces.

Termination of Insurance and Policies to be Submitted

Any insurance policies given hereunder shall cover all Contractor-performed work the Contractor in connection with the work in the introductory paragraph within railroad right-of-way, but shall not be liable for accidents occurring after acceptance of the completed project by the Department. Such policies shall contain a clause requiring 30 days written notice be given to the Engineer and to the appropriate Railroad Company, prior to cancellation or change.

Submit to the Engineer the original and one copy of the Commercial General Liability Policy, one certified duplicate copy of all other policies, and certificates of insurance in an original and two copies as required by these Project Special Provisions.

No extra allowance will be made for the insurance required hereunder. The entire cost shall be included in the contract unit price bids for other pay items.

The named insured under the commercial General Liability Insurance Policy is the respective Railroad Company, and the designation of the job site description of work is as follows: All

◆ **Revision No. 1, April 10, 2017 – This document supersedes version originally issued and sealed by J. Todd Brooks, NCPE No. 017586 on 12/28/2016.**

U-4715B**ITS-35****Buncombe County**

construction on the <<RAILROAD COMPANY>> right-of-way on NCDOT Project No. U-4715B in Asheville and Buncombe County, North Carolina.

3. Flagging Protection or Watchman Service

Provide 72 hours advance notice to Norfolk Southern (NS) in order that flagging service can be arranged and provided. Do not undertake any work within the NS right-of-way until the flagman is at the job site.

Provide a minimum of 7 days advance notice to Blue Ridge Southern (BLU) in order that flagging service can be arranged and provided. Do not undertake any work within the BLU right-of-way until the flagman is at the job site.

4. Delays Caused by Operations of Others

Neither the Department nor the Railroad Company assumes any responsibility for any work performed by others in connection with the construction of the project, and the Contractor shall have no claim whatsoever against the Department or the Railroad Company for any inconvenience, delay, or additional cost incurred by the Contractor on account of such operations by others.

5. Time Extensions

No time extensions related to railroad encroachments will be allowed until the related work becomes the controlling factor relative to overall project completion.

6. Cooperation with Others

Cooperate with others participating in the construction of the project to the end that all work may be carried on to the best advantage.

7. Authority of Railroad Engineer

The authorized representative of the Railroad Company, hereinafter referred to as the Railroad Engineer, will have the final authority in all matters affecting the safe maintenance of railroad traffic of his company.

8. Interference with Railroad Operations

Arrange and conduct work so that there will be no interference with railroad operations, including train, signal, telephone and telegraphic services, or damage to the property of the Railroad Company or to the poles, wire, and other facilities of tenants on the rights-of-way of the Railroad Company. Wherever work is liable to affect the operations or safety of trains, first submit the method of doing such work to the Railroad Engineer for approval. However, such approval will not relieve the Contractor from liability.

Should conditions arising from or in connection with the work, require that immediate and unusual provisions be made to protect train operations and property of the Railroad Company, it shall be a part of the required services by the Contractor to make such provisions and if, in the judgment of the Railroad Engineer such provisions are insufficient, the Railroad Engineer or the Department may, at the expense of the Contractor, require or provide such provisions as may be deemed necessary.

9. Storage of Materials

Do not store materials and equipment where they will interfere with railroad operations, nor on the rights-of-way of the Railroad Company without first having obtained permission from the

◆ **Revision No. 1, April 10, 2017 – This document supersedes version originally issued and sealed by J. Todd Brooks, NCPE No. 017586 on 12/28/2016.**

Railroad Engineer. Such permission will be with the understanding that the Railroad Company will not be liable or damage to such material and equipment from any cause, and that the Railroad Engineer may move or require the Contractor to move, at the Contractor's expense, such material and equipment.

10. Completion and Acceptance of Work

Upon completion of the work, remove from within the limits of the railroad right-of-way all machinery, equipment, surplus materials, or rubbish and leave said rights-of-way in a neat and orderly condition. Acceptance of the work will be contingent upon final inspection by the Department and by the Railroad Company (if required by the Railroad Company) to determine if the work was completed satisfactorily in a manner acceptable to the Department and the Railroad Company.

1.4. CONSTRUCTION STAGING/MIGRATION

A. Introduction

This section addresses the general flow of construction in regards to communications throughout the life of the project. It is essential that the Contractor make every effort to minimize communications downtime to the traffic signals.

Follow the outline of construction described below. Update the construction schedule monthly. Submit a detailed field migration plan (including details of controller cabinet change-outs) and schedule to the Department for review and approval at least two weeks prior to the onset of work, and no later than 60 days after Notice to Proceed. Update the migration plan monthly and submit it at least five business days prior to each monthly construction meeting. Include details of controller cabinet change-outs, listing every intersection, existing and future control zone, and existing and future communication zone, and a schedule of the migration. Obtain approval from the Engineer in advance for any deviations from this sequence. Include information explaining how the following situations will be handled:

1. Existing pole-mount cabinet converted to base-mount,
2. Existing cabinet foundation retained,
3. Base-mount cabinet on new foundation,
4. Installation and splicing of fiber-optic drop cables,
5. Installation of drop cables into risers with existing fiber-optic cable,
6. Reel-to-reel splice locations,
7. Transitioning the Department's and the City's existing Translink32 closed-loop systems with on-street masters and the City's existing Traconex[®] controllers over to the new signal system software, changing out the controllers and switching from the existing serial fiber-optic and radio communications system to a new Ethernet-based fiber-optic and radio communications network,
8. Removal of existing fiber-optic communications cable, where Plans or Engineer require, once a controller cabinet has been changed out;
9. Removal of existing fiber-optic communications cable followed by installation of new fiber-optic communications cable in an existing underground conduit or existing riser where there is no spare conduit/riser to facilitate installation of new cable before removing the existing cable; and
10. How to coordinate with others at the time new cabinets are set to make the necessary signal changes at the TMC to get the controller online.

◆ **Revision No. 1, April 10, 2017 – This document supersedes version originally issued and sealed by J. Todd Brooks, NCPE No. 017586 on 12/28/2016.**

U-4715B

ITS-37

Buncombe County

Submit a System Design Report to the Engineer for Department review and approval prior to beginning any migration from the existing signal system and communications system to the new signal system and new Ethernet communications system. Submit the System Design Report in both hard copy and electronic form. Refer to “Submittal Data and Documentation” section of these Project Special Provisions for additional requirements.

B. General Requirements

Notify the NCDOT Signal Supervisor at (828) 298-0094 at least two weeks prior to the commencement of work on a particular communications channel to ensure that time-base coordination will be operating and effective during the time of communications interruption. Before the existing communication is interrupted within a control zone, verify that the time-based coordination plans are installed in all of the intersection controllers within the control zone. Place in time-base coordination only those signals within an existing closed-loop that are actively being migrated to the Ethernet communications system. Ensure that the time-based coordination plans from existing controllers are transferred to the replacement controllers at those same locations.

It is the intent of these Project Special Provisions to minimize the length of time signals are offline from either the existing or new communication system, thereby limiting the duration of the use of time-based coordination. **Do not take any existing controller off-line from signal system communications and implement time-base coordination without prior approval of the Engineer.** Reconnect the controller to the communications system within a timeframe mutually agreed to and approved by the Engineer in advance of the initial disconnection from system communications.

Verify time-base coordination in 2070E controllers that upon installation will not be immediately connected to communicate with the new signal system over the new Ethernet fiber-optic cable network. Verify time-base coordination in existing 2070L controllers that upon disconnection from existing coordinated communication will not be immediately replaced with 2070E controllers and cabinets and re-connected to the signal system over the new Ethernet fiber-optic cable network.

Verify the time reference on each controller at least once per week (by synchronizing with a National Standard Time source) while time-based coordination is in use and make any corrections necessary to maintain proper coordination. Reset the controller’s clock to the common time source if it has drifted. **Ensure that controllers’ internal clocks are all synchronized at least once per week to the same date and time of day.** Maintain the time synchronization in all controllers during any time that communication with the TMC is interrupted (i.e., while signals are offline).

Record the time and date of each visit, the activity performed and name of person who visited the cabinet and performed the clock maintenance activity. Maintain a record of clock maintenance activity in a single document and furnish to the Engineer for review upon request. Failure to visit each intersection that is not online to check and update clocks will result in **liquidated damages of \$1,500 per visit not performed.**

The overall construction shall proceed generally outward from the TMC due to the architecture of the existing closed-loop systems and the lack of a homerun wireline connection to the TMC. Start at the outer edges of an existing closed-loop system and work inward toward the

◆ **Revision No. 1, April 10, 2017 – This document supersedes version originally issued and sealed by J. Todd Brooks, NCPE No. 017586 on 12/28/2016.**

U-4715B**ITS-38****Buncombe County**

TMC. The existing closed-loop system (with radio or fiber-optic cable) will be progressively decommissioned as the new Ethernet-based fiber-optic communications system is built-out and brought online, starting at the outer reaches of the system boundaries and working inward toward the TMC.

Group the work by the existing closed-loop communications systems, allowing intersection migration to take place in discrete packages. The boundaries of the existing closed-loop systems may be obtained from the Department and the City of Asheville through the Engineer upon request. In addition to grouping work by existing closed-loop communications systems, further organize work by proposed communications ring. For one-way streets within closed-loop systems or proposed rings, start at the most upstream intersection and work downstream without skipping intersections.

Perform as much of the necessary “make ready” work as possible within a proposed Ethernet communications ring to be migrated before proceeding to the steps that follow. Make ready work includes: new underground conduits, new junction boxes, intercepted and rerouted conduits at new and existing junction boxes, fiber-optic cable overhead and in new conduit, cabinet foundation modifications, electrical service, etc.

Configure the Ethernet edge switches for the permanent IP addresses, VLANs, and other configuration data before their field installation.

Interrupt communications, replace cabinets and controllers, and migrate signals from the existing closed-loop system communications to the new Ethernet communications network as follows:

- a) Begin the process of replacing cabinets and controllers. Prior to installing each new cabinet and controller, configure and install the Ethernet edge switch in the cabinet and program or otherwise verify that time-based coordination is properly programmed. See “Backup Intersection Operation” subsection in the “Signal System Software” section of these Project Special Provisions for further details.
- b) As fiber-optic cable installation, splicing and testing is completed for an entire Ring, connect the Ethernet edge switches to establish communication to the Ethernet core switch.
- c) Upon successful testing, integrate into the new central system software under Ethernet communications.

Construct and splice drop cables to existing and proposed CCTV cameras while maintaining the existing communications. Migrate the existing and proposed cameras as the adjacent traffic signals are migrated to new system whenever possible.

Complete the work of migrating all the signals in one Ethernet communications ring before moving to the next ring. Exceptions to the requirements in this section must be approved by the Engineer.

Once migration begins on a given communications ring, continue migrating signals along that ring until all of the communications ring is complete before beginning migration of signals residing along another communications ring. Complete the intersection migrations in a communications ring within the number of workdays equal to no more than the number of signalized intersections in the communications ring. **Liquidated damages** for failure to

◆ **Revision No. 1, April 10, 2017 – This document supersedes version originally issued and sealed by J. Todd Brooks, NCPE No. 017586 on 12/28/2016.**

U-4715B

ITS-39

Buncombe County

complete intersection migrations and restore system communications to all intersections in the communications ring within the specified time are **\$1,500 per 24-hour period or any portion thereof.**

Exceptions to the requirements in this section must be approved by the Engineer.

Once all signal migration within a ring is complete, establish or otherwise verify that time-based coordination is properly programmed on all existing controllers in the ring. (Refer to preceding subsection 1.4(B) "General Requirements".) Then contact the NCDOT Traffic Signal Supervisor to arrange for communication on the fiber-optic communication. At this point, disconnect and remove existing communications cable where designated in the Plans.

Upon successful testing, integrate the communications ring and all devices connected to that ring into the central system software under Ethernet communications.

Install system timing and graphics as per the requirements of the previous subsection "Timing of Signals."

As each Ethernet ring is completed and lit, test communications to each Ethernet edge switch in that ring as per the requirements of "Testing and Acceptance" section of these Project Special Provisions.

Prior to the end of any work day, ensure that communication between the TMC and existing signal controllers still connected to the existing communications cable is reestablished and working correctly.

C. Staging Concept

The existing communications infrastructure is a collection of approximately 22 closed-loop signal systems, each with an on-street master and dial-up modem. Not all traffic signals are in one of these closed-loop systems. Within a closed-loop system, there is either fiber-optic cable or 900 MHz radios for communications.

Due to the lack of existing wired homerun communications to the TMC and the incompatibility of the new system without on-street masters with the existing system that requires on-street masters, the new communications system must be built out from the TMC and off the new trunk fiber-optic cable.

The sequence described below is designed to minimize the downtime between the old and new systems and maintain the connection to the various rings and controllers. The Contractor may elect to perform the major steps identified for each ring in a sequence different than proposed below for each ring; however, each major step must be completed before moving to the next major step regardless of sequence and the sequence must be approved by the Department.

Prior to the initiation of the first step of migration in each ring, follow the steps described below in the subsection entitled "Field Infrastructure."

Construction of the signal system upgrade and expansion and migration from the existing to the new system is envisioned to occur in the following general stages:

◆ **Revision No. 1, April 10, 2017 – This document supersedes version originally issued and sealed by J. Todd Brooks, NCPE No. 017586 on 12/28/2016.**

U-4715B

ITS-40**Buncombe County**

Stage 1: Begin construction of field infrastructure (i.e., messenger cable, risers, underground conduits, junction boxes, foundation modifications, CCTV poles/cameras/cabinets, fiber-optic communications cable). Begin “make-ready” work at the TMC City of Asheville Transportation Department in City Hall, and the NCDOT Division Offices and the routes listed in Stage 2 below.

Construct the integrated pushbutton accessible pedestrian signals (APS) as shown in the Plans as soon as possible upon receipt of notice to proceed.

Stage 2: Construct the trunk fiber-optic communications ring along Fairview Road, Swannanoa River Road, Tunnel Road, College Street, S. Charlotte Street, Biltmore Avenue, Hendersonville Road, I-40, Sweeten Creek Road, Craven Street, and back to Fairview Road. Along Hendersonville Road, I-40, Sweeten Creek Road, Craven Street, and back to Fairview Road construct both 96-strand fiber-optic cables at the same time.

Complete field infrastructure construction for the Rings 1, 2, 3, 15, 16, and parts of 4 and 19 of the new communications system and integrate these rings and controllers into the new central software using new servers at the TMC.

Construct the arterial trunk lines north of the downtown area and migrate by whole rings and integrate the rest of Ring 19, and all of Rings 20 and 21.

Stage 3: Construct the trunk fiber-optic communications ring along Hendersonville Road from south of I-40, Long Shoals Road, Clayton Road, Brevard Road, Haywood Road, Craven Street, Patton Avenue, Clingman Avenue, Hilliard Avenue, and Biltmore Avenue. At the intersection of Biltmore Avenue and S. Charlotte Street splice the trunk cable constructed in this Stage to that constructed in Stage 2.

Construct the arterial trunk lines along the trunk cable in Stage 2 and then migrate by whole rings and integrate the rest of Ring 4, Rings 5, 6, 7, 8, 9, 10, 11, 12, 13, 14, and 18.

Stage 4: Construct the wireless Ring 17 (west side of the CBD) and the wireless portion of Ring 19 (east side of the CBD) into new the central software using new servers at the TMC. Construct the wireless portion of Ring 19 with Ring 17 to maintain timing coordination of the signal system. Replace the wireless CCTV system at the interchange of I-240/240/26.

If the schedule of STIP Project I-5504 along Brevard Road impacts Stage 3, construct the trunk cable up the limits of STIP I-5504 and make end splices so the rings along this trunk cable will become folded rings and be fully functional with redundancy. Make the splices to the trunk 60-strand cable along Brevard Road installed under I-5504 when that cable has been tested and accepted.

The “Field Infrastructure”, “Communications Migration” and “TMC Migration” subsections that follow describe the envisioned construction sequence and migration in greater detail. Be advised that some work in each of these subsections is concurrent with and interrelated to work described in the other subsections.

◆ **Revision No. 1, April 10, 2017 – This document supersedes version originally issued and sealed by J. Todd Brooks, NCPE No. 017586 on 12/28/2016.**

D. Field Infrastructure – Stages 1-4

The approach to maintaining and maximizing communications to all signals and CCTV cameras throughout the construction process requires that the new fiber-optic communications infrastructure be constructed while the existing communications infrastructure remains in place and operational. This will allow the intersections, even those in close proximity to one another, to function on the existing communications system until such time as they are migrated to the new Ethernet fiber-optic communications system. The new Ethernet fiber-optic communications network is comprised of:

- New aerial cable overlashed to existing communications cable while the existing communications cable remains in use. Install messenger cable and down guys before beginning any overhead fiber-optic cable installation. The overlashed existing communications cable will be abandoned in place after construction. Certain aerial routes are on new pole lines or deviate from the course of the existing communications cable. Existing communications cable that is not overlashed (e.g., in risers, where route changes, etc.) may be removed along with existing splice cabinets, unused risers and abandoned junction boxes where specified in the Plans or directed by the Engineer, after communications have completely migrated to the new fiber-optic cable and the existing communications cable is no longer in use.
- New underground cable in existing underground conduit. New fiber-optic cable will be pulled through an existing spare conduit that runs alongside the conduit containing the existing cable(s) where a spare conduit is available. Where there is no spare conduit in the existing underground run, the fiber-optic cable will have to be installed inside the same conduit that contains the existing cable(s); in some cases, this may require removal of one or more existing communications cables to enable pulling of the new cable.
- New underground cable in a new trenched, drilled or bored underground conduit.
- New NCDOT fiber-optic cable being installed under STIP project I-5504 (I-26 at Brevard Road), and possibly segments of other existing NCDOT fiber-optic cable, that will be spliced into the new fiber-optic network and incorporated into the expanded signal system. (NOTE: The U-4715B signal system contractor shall be responsible for performing all splicing of the Asheville signal system communications cable).

1. Step 1

The Department has joint-use permits for the proposed new attachments of aerial fiber-optic communications cable. Joint-use permits issued by the utility pole owners expire 120 days from the date of issuance. The Contractor shall commence installation of messenger cables and guy assemblies at the outset of construction and work continuously and expeditiously to complete this work prior to the joint-use permit expiration date. In the event that this work cannot be completed within 120 days, notify the Engineer 20 calendar days in advance to allow the City to request an extension of the permit.

2. Step 2

Begin construction of the trunk cables along the major routes. For those routes with overhead cable, overlash the new fiber-optic cable to the existing fiber-optic cable or new messenger cable. For the underground routes, install the new cable:

- In spare ducts, where available
- In the same conduit as the existing fiber-optic cable where there is no available, accessible spare conduit, or
- In new conduits installed as part of this project.

In a few locations, the use of the existing occupied conduit may require removal of one or more existing communications cable. Provide cable storage for subsequent and future splices where called for in the Plans.

These trunk cables will provide homerun routes for Ethernet communications to the Department's TMC at 11 Old Charlotte Highway. Establish Ethernet communications and test as per requirements of the "Testing and Acceptance" section of these Project Special Provisions.

3. Step 3

Construct the branch cables to the arterials off the trunk fiber-optic routes and non-redundant routes and splice them to the trunk cables constructed in Step 2.

4. Step 4

Construct and splice drop cables to local intersections while maintaining the existing communications. The original traffic signal system was largely constructed with drop and repeat transceivers and fiber-optic cable that daisy-chained through the each traffic signal controller cabinet. At many locations, the new drop cable can be installed into the cabinet while maintaining the existing communications cable either by using a new riser or conduit entrance installed per the Plans or by installing the drop cable in the existing conduit or riser alongside the existing cables. Where the drop cable cannot be installed while the existing cables remain inside the existing conduit or riser, initially coil and store the new drop cable on the pole or span above the occupied riser or in a junction box adjacent to the cabinet. Subsequently remove the existing cable(s) and pull the new drop cable into the cabinet during controller and cabinet change-out.

5. Step 5

Configure the edge switches for the permanent IP addresses, VLANs, and other configuration data before their field installation.

Once the communications cable plant in Step 4 is completed and successfully tested, and continuous communications paths are established with outlying signals, begin the process of transferring communications from the old fiber-optic network to the new fiber-optic network. See the preceding subsection 1.4(B) "General Requirements" for further details. Exceptions to the requirements in this section must be approved by the Engineer. Notify the City of Asheville Signal System Supervisor Joel Tweed at (828) 259-5873 and NCDOT Traffic Signal Supervisor at (828) 298-0094 at least two weeks prior to the commencement of work on a particular communications channel for their respective agencies to ensure that time-base coordination will be operating and effective during the time of communications interruption. As each Ethernet ring is completed and lit, test the intersection communications as per the requirements of "Testing and Acceptance" section of these Project Special Provisions.

◆ **Revision No. 1, April 10, 2017 – This document supersedes version originally issued and sealed by J. Todd Brooks, NCPE No. 017586 on 12/28/2016.**

Generally, start at the outer edge of the existing communications circuit and work towards the TMC. Group the work by the existing closed-loop communications systems, allowing intersection migration to take place in discrete packages. The boundaries of the existing closed-loop systems are documented in the “System Boundaries and Control Sections Technical Memorandum (Task 7.1)”, dated May 2016, a copy of which may be obtained from the Engineer upon request.

Interrupt communications, replace cabinets and controllers, and migrate signals from the existing closed-loop fiber-optic communications systems to the new fiber-optic communications network. Replace and migrate CCTV cameras at the same time. If the communications conversion in the subject closed-loop system or Ethernet ring interrupts the communication in another closed-loop system or Ethernet ring, the Contractor must re-establish communication continuity in the adjacent closed-loop communications system or Ethernet ring before any work can continue.

After the controllers are replaced, additional database work must be performed. Revise the offset references when the NEMA controllers are replaced with 2070s. The NEMA controllers use offsets referenced to the end of the coordinated phase green. The 2070s with Oasis IP-based firmware use as an offset reference to the beginning of the green interval of the coordinated phase. If there are two coordinated phases such as two and six, then the new reference is to be the beginning of the coordinated phase green of the second phase.

6. Step 6

Upon successful testing, integrate the traffic signals into the central system software under Ethernet communications.

As each Ethernet circuit is completed and lit, test intersection communications as per the requirements of “Testing and Acceptance” section of the Project Special Provisions.

Ensure controller cabinet change-outs adhere to all requirements listed in Subsections 1.3(A) “General” and 1.3(H) “Utility Services” as well as in the “Temporary Traffic Control” section of these Project Special Provisions.

Prior to the end of any work day, ensure that communications between the Ethernet edge switches and the Ethernet core switch in TMC, are reestablished, if they were interrupted, and are working correctly.

7. Step 7

Conduct system testing, acceptance and burn in period.

E. Communications Migration – Stage 2

The Stage 2 migration to the cable plant in the new Ethernet communications network will occur in five major steps. Maintain communications for the existing closed-loop signal systems and CCTV systems from the TMC and the City Transportation Department.

The five major steps for the Stage 2 migration are:

Step 1: Fairview Road (Liberty Street to Swannanoa River Road), Swannanoa River Road (between Fairview Road and Tunnel Road), Tunnel Road (Swannanoa River Road to College Street), College Street, S. Charlotte Street, Biltmore Avenue/Hendersonville Road, I-40, Sweeten Creek Road (north of I-40), Crayton Street, Liberty Street and back to Fairview Road.

Step 2: Local streets (S. Tunnel Road, Swannanoa River Road, Fairview Road, Charlotte Highway, Meadow Road, McDowell Street, Victoria Road, Southside Drive, Hospital Drive, Sweeten Creek Road between I-40 and Blue Ridge Parkway, and Porters Cove Road) connecting to the above cables in Stage 2, Step 1 and Stage 2, Step 2.

Step 3: Local streets (N. Charlotte Street, Orange Street, and Merrimon Avenue) connecting to the above cables in Stage 2, Step 1 and Stage 2, Step 2.

Step 4: Local streets (Chestnut Street, Broadway, Weaverville Road, and Woodfin Street) connecting to the above cables in Stage 2, Step 1 and Stage 2, Step 2.

Step 5: Migrate the local controllers and cameras to the new Ethernet communications system.

1. Step 1

Construct the 96-strand fiber-optic cable along Fairview Road, Tunnel Road, College Street, S. Charlotte Street, I-40, Sweeten Creek Road, Crayton Road, and back to Fairview Road.

Utilize the new building entrance conduits at the TMC and the City Transportation Department and pull in the proposed fiber cables.

Construct the 60-strand fiber-optic cable along Biltmore Avenue and Hendersonville Road.

2. Step 2

Construct the fiber-optic cable along the non-redundant routes for Rings 1, 2, 3, 15, 16 and parts of 4 and 19. Install and integrate the 900 MHz radios to bridge the Blue Ridge Parkway along Tunnel Road.

3. Step 3

Construct the 24-strand cable along N. Charlotte Street, Orange Street, and Merrimon Avenue for Rings 19, 20, and 21.

4. Step 4

Construct the 24-strand cable along Chestnut Street, Broadway, Weaverville Road, and Woodfin Street for Rings 20 and 21. Install and integrate the 900 MHz radios Woodfin Street.

U-4715B

ITS-45

Buncombe County

5. Step 5

Migrate the communications to the TMC and the City Transportation Department over to the new Ethernet communications system. This completes the migration of Rings 1, 2, 3, part of 15, 16, 19, 20, 21 and part of 4.

F. Communications Migration – Stage 3

The Stage 3 migration to the cable plant in the new fiber-optic Ethernet communications network will occur in six major steps. Maintain communications for the existing closed-loop signal systems and CCTV systems from the TMC and the City Transportation Department.

The **six major steps** for the Stage 3 migration are (listed in order):

- Step 1:** Construct the trunk fiber-optic communications ring along Hendersonville Road from south of I-40 to Long Shoals Road, Long Shoals Road, Clayton Road, Brevard Road (north of Clayton Road), Haywood Road, Craven Street, Patton Avenue, Clingman Avenue, Hilliard Avenue, and Biltmore Avenue.
- Step 2:** At the intersection of Biltmore Avenue and S. Charlotte Street, splice the trunk cable constructed in this Stage to that constructed in Stage 2.
- Step 3:** Construct the 24-strand fiber-optic communications cable along Hendersonville Road south of Long Shoals Road, Airport Road, Sweeten Creek Road, Brevard Road (south of Clayton Road), and Smokey Park Highway.
- Step 4:** Construct three 900 MHz radio systems.
- Step 5:** Local streets (Sand Hill Road, Monte Vista Road, Leicester Highway, Louisiana Avenue, State Street, Riverside Drive and portions of Patton Avenue west of the French Broad River) connecting to the above cables.
- Step 6:** Migrate the local controllers and cameras to the new Ethernet communications system.

1. Step 1

Construct the 60-strand fiber-optic cable along Hendersonville from south of I-40 to Long Shoals Road, Long Shoals Road, Clayton Road, Brevard Road (north of Clayton Road), Haywood Road, Craven Street, Patton Avenue, Clingman Avenue, Hilliard Avenue, and Biltmore Avenue.

Construct the 60-strand fiber-optic cable along Biltmore Avenue and Hendersonville Road.

2. Step 2

At the intersection of Biltmore Avenue and S. Charlotte Street, splice the trunk cable constructed in this Stage to that constructed in Stage 2. This completes the construction of the trunk cables.

◆ **Revision No. 1, April 10, 2017 – This document supersedes version originally issued and sealed by J. Todd Brooks, NCPE No. 017586 on 12/28/2016.**

U-4715B

ITS-46

Buncombe County

3. Step 3

Construct the 24-strand cable along Hendersonville Road south of Long Shoals Road, Airport Road, Sweeten Creek Road, Brevard Road (south of Clayton Road), and Smokey Park Highway.

4. Step 4

Construct three 900 MHz radio systems on Pensacola Avenue, Amboy Road, and Biltmore Avenue between Alston Street and Hilliard Avenue.

5. Step 5

Construct the 24-strand cable along the local streets (Sand Hill Road, Monte Vista Road, Leicester Highway, Louisiana Avenue, State Street, Riverside Drive and portions of Patton Avenue) connecting to the above cables.

6. Step 6

Migrate the communications to the TMC and the City Transportation Department over to the new Ethernet communications system. This completes the migration of Rings 5, 6, 7, 8, 9, 10, 11, 12, 13, 14, 18, and the remainder of 15.

G. Communications Migration – Stage 4

The Stage 4 migration to the cable plant in the new Ethernet communications network will occur in four major steps. Maintain communications for the existing closed-loop signal systems and CCTV systems from the TMC and the City Transportation Department.

The **four major steps** for the Stage 4 migration are (listed in order):

Step 1: Construct the wireless Ring 17 (west side of the CBD).

Step 2: Construct the wireless portion of Ring 19 (east side of the CBD).

Step 3: Replace the wireless CCTV system at the interchange of I-240/240/26.

Step 4: Migrate the local controllers and cameras to the new Ethernet communications system.

1. Step 1

Construct the wireless Ring 17 (west side of the CBD). Coordinate this work with Step 2 of this Stage to minimize the downtime of the coordinated signal systems along the downtown streets.

2. Step 2

Construct the wireless portion of Ring 19 (east side of the CBD).

3. Step 3

Construct the wireless CCTV hub at I-26 and Pond Road. Replace the wireless CCTV system at the interchange of I-240/240/26. Coordinate with the Engineer to disconnect the cellular modem at the existing hub cabinet.

◆ **Revision No. 1, April 10, 2017 – This document supersedes version originally issued and sealed by J. Todd Brooks, NCPE No. 017586 on 12/28/2016.**

4. Step 4

Migrate the communications to the TMC and the City Transportation Department over to the new Ethernet communications system. This completes the migration of Rings 17 and 19.

H. TMC Migration – Stage 4

The block diagrams for the new signal system shown on the Plans depict the existing system equipment to be retained and the new equipment to be installed. The proposed sequence is described below.

1. Step 1

The Department will remove or relocate their non-essential equipment, furniture and stored materials in the server room to facilitate the temporary operations. Relocate and maintain the operation of the existing CCTV and signal systems to facilitate the new system communications and equipment.

2. Step 2

The Department will construct new electrical outlets, relocate NCDOT LAN jacks, relocate a door between the server and control rooms and replace the main door to the control room of the TMC as shown in the Plans.

3. Step 3

Maintain the operation of the existing CCTV monitoring system and Translink[®] signal system. Install the new communications racks and cable trays in the server room.

4. Step 4

Coordinate the installation of trunk cables into the TMC with the field infrastructure. Construct the directionally drilled conduits across the parking lot of the maintenance yard, risers, junction boxes and conduit entry into the building.

5. Step 5

Install Ethernet core switch, server(s), monitors, workstations, and all necessary equipment at the TMC and the monitor, workstation and Ethernet edge switch in the City Transportation Department in City Hall. Do not relocate the video server at this stage. Install the network management software. Configure the central software applications.

6. Step 6

Setup a test facility to configure local equipment. The test facility shall utilize the same models of equipment to test the network configuration as is being installed on the project. Configure the Ethernet core switch for the permanent IP addresses, VLANS, and other configuration data before its installation.

Begin building the device database. Convert the signal timing data and build the system and intersection graphics.

7. Step 7

Move the traffic signals from the existing communications cables to the new Ethernet over single-mode fiber-optic cables by connecting to the Ethernet switches. Move the CCTV cameras from the existing communications cables to the new Ethernet over single-mode fiber-optic cables.

◆ **Revision No. 1, April 10, 2017 – This document supersedes version originally issued and sealed by J. Todd Brooks, NCPE No. 017586 on 12/28/2016.**

U-4715B

ITS-48

Buncombe County

1.5. MEASUREMENT AND PAYMENT

There will be no direct payment for work covered in this section. Payment at the contract unit prices for the various items in the contract will be full compensation for all work covered by this section. Include the incidental costs for furnishing and/or installing materials and equipment expressly required under the contract for successful completion of the contract, but whose measurement and payment is not specifically stated under any of the contract pay items, into the unit cost(s) for the various items in the contract.

2. TEMPORARY TRAFFIC CONTROL

2.1. DESCRIPTION

Furnish, install, maintain, relocate, and remove temporary traffic control devices in accordance with these Project Special Provisions, the Transportation Management Plan, the MUTCD, and Roadway Standard Drawings to maintain and control vehicular and pedestrian traffic in a safe and efficient manner during signal system construction. All temporary traffic control devices furnished by the Contractor shall remain the property of the Contractor, unless otherwise specified in the contract.

2.2. GENERAL REQUIREMENTS

A. Maintenance of Traffic

The Contractor will be required to maintain traffic, both vehicular and pedestrian, within the limits of the project, including roadways that cross or intersect the project, unless otherwise provided for in the contract or approved by the Engineer. The Contractor shall conduct his work in a safe manner that will create a minimum amount of inconvenience to traffic, both vehicular and pedestrian.

Maintain vehicular and pedestrian traffic through work zones in accordance with these Project Special Provisions, the MUTCD, and *Roadway Standard Drawings*, 23 CFR 630 Subparts J and K and the Transportation Management Plan (TMP).

Mark all hazards with signs, barricades, drums or other warning devices until the hazard is eliminated.

B. Temporary Lane Closures

1. General

Operate all equipment and personnel within the designated work area during lane closures. Do not impede or stop traffic for the purpose of performing construction related work on the traffic side of the lane closure, except when called for in the Transportation Management Plan.

Install lane closures with the traffic flow, beginning with devices on the upstream side of traffic. Remove lane closures against the traffic flow, beginning with devices on the downstream side of traffic.

Vehicles used to install or remove lane closures shall have flashing or rotating beacons.

2. Intersections

When construction proceeds through an intersection, provide flagger(s) and all other necessary Traffic Control as required by the Plans to direct the traffic through the intersection. When an intersection is signalized, have authorized personnel place the signal in flash mode prior to beginning work in the intersection.

When it is necessary to close a lane of traffic for construction on the departure (downstream) side of an intersection, implement the lane closure on the approach (upstream) side of the intersection. Close the appropriate lane of dual turn lanes that would otherwise turn into the lane that is closed on the departure side of the intersection.

◆ **Revision No. 1, April 10, 2017 – This document supersedes version originally issued and sealed by J. Todd Brooks, NCPE No. 017586 on 12/28/2016.**

U-4715B**ITS-50****Buncombe County****C. Traffic Stoppage**

Limit the stoppage of traffic to times specified in the Plans. Provide enough time between consecutive stoppages to allow the traffic queue to dissipate.

D. Traffic Control Supervision

Provide the service of at least one qualified work zone supervisor. The work zone supervisor shall have the overall responsibility for the proper implementation of the traffic management plans and ensure all employees working inside the NCDOT and City rights-of-way have received the proper training appropriate to the job decisions each individual is required to make.

The work zone supervisor is not required to be on site at all times but shall be available to address concerns of the Engineer. The name and contract information of the work zone supervisor shall be provided to the Engineer prior to or at the preconstruction conference.

Qualification of work zone supervisors shall be done by an NCDOT approved training agency or other approved training provider. For a complete listing of these, see the Work Zone Traffic Control's webpage: <https://connect.ncdot.gov/projects/WZTC/Pages/Training.aspx>

Coordinate with and cooperate with traffic control supervisors of adjacent or overlapping construction projects to insure safe and adequate traffic control is maintained throughout the projects at all times including periods of construction inactivity in accordance with Article 105-7 of the *Standard Specifications*.

E. Vehicular Access

Maintain continuous and safe vehicular access, including but not limited to, all residences, businesses, schools, police and fire stations, hydrants, other emergency services, hospitals and mailboxes. Conduct operations in such a manner as to limit the inconvenience to property owners.

F. Pedestrian Access

Maintain continuous and safe pedestrian access, including but not limited to, all residences, businesses, schools and mailboxes. Conduct operations in such a manner as to limit the inconvenience to pedestrians. Pay special attention to pedestrian areas used by visually-impaired pedestrians. Coordinate with local Orientation and Mobility Specialists to make appropriate provisions for visually impaired pedestrians when construction activities will disrupt pedestrian paths that they normally use.

Protect open excavations within or adjacent to areas subject to pedestrian traffic from pedestrian intrusion by surrounding the excavation/hazard with orange plastic mesh construction fencing (also referred to as safety fence, tree protection barricade, warning fence, etc.) or other method approved by the Engineer. Do not use tape, flagging, rope or plastic chain strung between barricades, cones or stakes.

Determine the extent of pedestrian needs through engineering judgment or by the traffic control supervisor responsible for the work zone. Inspect the work zone regularly so effective pedestrian traffic is maintained. When pedestrian movement through or around a work site is necessary, provide a separate usable footpath. If the previous pedestrian facility was accessible to pedestrians with disabilities, provide a footpath during temporary traffic control that is accessible. Do not have any abrupt changes in grade or terrain that could cause a tripping hazard

◆ **Revision No. 1, April 10, 2017 – This document supersedes version originally issued and sealed by J. Todd Brooks, NCPE No. 017586 on 12/28/2016.**

U-4715B**ITS-51****Buncombe County**

or could be a barrier to wheelchair use. Provide barriers and channelizing devices that are detectable to pedestrians who have visual disabilities. Provide temporary pedestrian facilities that are made of concrete, asphalt or other suitable material as approved by the Engineer at all locations where the existing sidewalks have been removed for construction operations.

Do not sever or move pedestrian facilities for non-construction activities such as parking for vehicles and equipment. Separate pedestrian movements from both work site activity and vehicular traffic.

G. Greenways

Comply with all requirements of the "Pedestrians" for all work that is adjacent to, encroaches upon or is within City of Asheville Greenways. Maintain and make provisions for bicycle ingress and egress and provide for safe passage of bicycles along greenways in manner similar to the requirement for pedestrians. At least two weeks prior to beginning any work that may affect or disrupt pedestrian and bicycle traffic along a City Greenway, coordinate with the City of Asheville Department of Transportation concerning any special requirements, any special events like bike races, and work day/hour limitations for the affected Greenway. Maps showing the location and routes of the City's Greenways may be found at the following Web address:

<http://www.ashevillenc.gov/Departments/Transportation/Greenways.aspx>

H. Alternate to Transportation Management Plan

If desired, submit an alternate TMP a minimum of 30 calendar days in advance of the anticipated implementation to allow for adequate review time. Do not implement alternate plans for traffic control until approved in writing and properly sealed. No adjustment in compensation or extension of the completion date(s) will be allowed due to the review time of the alternate. If an alternate TMP is implemented, the Contractor shall be responsible for any unanticipated changes to subsequent Steps.

I. Temporary Traffic Control Plan not fully Covered in the Contract

When the Transportation Management Plan does not cover a particular work function, notify the Engineer to allow for the development or modification of a sealed set of the Transportation Management Plans.

2.3. MATERIALS

A. Work Zone Traffic Control Devices

Refer to Division 10 of the *Standard Specifications*.

Use temporary traffic control devices that comply with 23 CFR 630 Subpart K. Provide a Type 7 material certifications in accordance with Article 106-3 of the *Standard Specifications* at least 72 hours before use for all used temporary traffic control devices.

Provide temporary traffic control devices that are listed on the NCDOT Approved Product List.

◆ **Revision No. 1, April 10, 2017 – This document supersedes version originally issued and sealed by J. Todd Brooks, NCPE No. 017586 on 12/28/2016.**

U-4715B

ITS-52

Buncombe County

B. Work Zone SignsRefer to Division 10 of the *Standard Specifications*:

| Item | Section |
|-------------------------|----------------|
| Barricade Mounted Signs | 1089-3 |
| Work Zone Signs | 1089-1 |
| Work Zone Sign Supports | 1089-2 |

Portable work zone signs shall be roll up or approved composite substrates. Use portable work zone signs only with portable work zone sign stands specifically designed for one another.

Provide portable work zone sign stands, portable signs and sheeting that meet NCHRP 350 for Category II traffic control devices and are listed on the NCDOT Approved Products List.

Provide portable work zone signs and stands that are crash tested together as a system by the manufacturer. Poor performance of portable work zone signs or portable work zone sign stands at any site, whether or not related to a specific contract, will be grounds for non-acceptance of a product on any project under contract.

C. Flashing Arrow BoardsRefer to Division 10 of the *Standard Specifications*:

| Item | Section |
|-----------------------|----------------|
| Flashing Arrow Boards | 1089-6 |

Use arrow boards that are on the NCDOT Approved Product List.

Poor performance of arrow boards at any site, whether or not related to a specific contract, will be grounds for non-acceptance of a product on any project under contract.

D. Portable Changeable Message SignsRefer to Division 10 of the *Standard Specifications*:

| Item | Section |
|-----------------------------------|----------------|
| Portable Changeable Message Signs | 1089-7 |

Use portable changeable message signs that are on the NCDOT Approved Products List.

Poor performance of portable changeable message signs at any site, whether or not related to a specific contract, will be grounds for non-acceptance of a product on any project under contract.

E. DrumsRefer to Division 10 of the *Standard Specifications*:

| Item | Section |
|-------------|----------------|
| Drums | 1089-5 |

Provide drums that are on the NCDOT Approved Products List.

◆ **Revision No. 1, April 10, 2017** – *This document supersedes version originally issued and sealed by J. Todd Brooks, NCPE No. 017586 on 12/28/2016.*

U-4715B

ITS-53

Buncombe County

F. ConesRefer to Division 10 of the *Standard Specifications*:

| Item | Section |
|-------------|----------------|
| Cones | 1089-4 |

Provide cones that are on the NCDOT Approved Products List.

G. BarricadesRefer to Division 10 of the *Standard Specifications*:

| Item | Section |
|-------------|----------------|
| Barricades | 1089-3 |

Provide barricades that meet NCHRP 350 for Category II traffic control devices and are on the NCDOT Approved Products List.

H. FlaggersRefer to Division 10 of the *Standard Specifications*:

| Item | Section |
|-------------|----------------|
| Flaggers | 1089-10 |

I. Truck Mounted AttenuatorsRefer to Division 10 of the *Standard Specifications*:

| Item | Section |
|----------------------------------|----------------|
| Truck Mounted Impact Attenuators | 1089-9 |

Use TMAs that meet NCHRP 350 Test Level II or III for work zone traffic control devices and are on the NCDOT Approved Products List.

Historical performance of the TMA will help determine the future use of the material by the Department, even if the TMA has been approved. Poor performance of TMA at any site, whether or not related to a specific contract, will be grounds for non-acceptance of a product on any project under contract.

J. Skinny DrumsRefer to Division 10 of the *Standard Specifications*:

| Item | Section |
|--------------|----------------|
| Skinny Drums | 1089-5 |

Provide skinny drums that are on the NCDOT Approved Products List.

◆ **Revision No. 1, April 10, 2017** – *This document supersedes version originally issued and sealed by J. Todd Brooks, NCPE No. 017586 on 12/28/2016.*

2.4. CONSTRUCTION METHODS

A. Work Zone Traffic Control Devices

Ensure all traffic control devices inspected and approved before using them on the project. Install temporary traffic control devices before construction operations begin and during the proper phase of construction. Maintain and relocate temporary traffic control devices during the time they are in use. Keep these devices in place as long as they are needed and immediately remove thereafter. When operations are performed in stages, install only those devices that apply to the present conditions.

B. Work Zone Signs

1. Work Zone Signs (Barricade Mounted)

Mount approved composite or roll-up signs to barricade rails so that the signs do not cover more than 50% of the top two rails or 33% of the total area of the three rails. Mount signs at least 1 foot from the ground to the bottom of the sign.

2. Work Zone Signs (Portable)

Install the portable work zone sign and sign stand to stand plumb within 10° left and right, within 20° front and back and be capable of standing erect in windy conditions.

Install roll-up or approved composite signs at least 1 foot from the bottom of the sign to the edge of pavement elevation on two-lane two-way roadways and at least 5 feet from the bottom of the sign to the edge of pavement elevation on multi-lane roadways.

Clean the sign face prior to use.

When not in use for periods longer than 30 minutes, lay the portable work zone sign flat on the ground and collapse the sign stand and lay it flat on the ground.

C. Flashing Arrow Boards

Use arrow boards that have the capability to display mode selections.

Do not use straight-line caution or chevron displays.

Mount flashing arrow boards on trucks, trailers, or other mobile units.

Expedite repairs due to failure, malfunction or damage to an arrow board. Furnish another arrow board approved by the Engineer during the repair time. Repair or replace arrow boards immediately; otherwise, suspend all construction activities requiring the use of the sign until the sign is restored to operation.

Perform all maintenance operations recommended by the manufacturer of the sign.

D. Portable Changeable Message Signs

Mount all portable changeable message signs on a trailer or truck so as to support the message board in a level position and in accordance with the Plans. Align and sight the portable changeable message sign to provide optimal driver visibility. Messages on a portable changeable message sign shall consist of no more than 2 phases, and a phase shall consist of no more than 3 lines of text. Each phase shall be capable of being understood by itself, regardless of the order in which it is read. Messages shall be centered and uppercase within each line of the legend. If more than one portable changeable message sign is simultaneously legible to road users, then

◆ **Revision No. 1, April 10, 2017 – This document supersedes version originally issued and sealed by J. Todd Brooks, NCPE No. 017586 on 12/28/2016.**

only one of the signs shall display a sequential message at any given time. As guidance, the display time for each phase shall be at least 2 seconds, and the sum of the display times for both of the phases shall be no more than 8 seconds. Sign operator will adjust the display rate so the 2 phase message can be understood by the motorist approaching the sign at the posted speed limit. Relocate the units for the various stages of construction as shown in the Plans or as needed to adequately inform the motorists.

Provide an experienced operator for the portable changeable message sign during periods of operation to ensure that the messages displayed on the sign panel are in accordance with the Plans and in accordance with message content guidelines. Ensure that the message sign is illuminated properly to meet the existing light conditions, and that all adjustments for operation of the sign are made as needed to properly guide motorists.

Expedite repairs due to failure, malfunction, or damage to a portable changeable message sign. Furnish another portable changeable message during the repair time. Repair and/or replace portable changeable message sign immediately; otherwise, suspend all construction activities requiring the use of the sign until the sign is restored to operation.

Perform all maintenance operations recommended by the manufacturer of the sign. Include the periodic cleaning of the sign face and associated solar panels in maintenance operations.

E. Drums

Use the same type of reflective sheeting on all drums installed at any one time during the life of the project. Spacing of these devices is equal in feet to the speed limit in the taper and twice the speed limit in the tangent sections

Use a ballasting method in accordance with the manufacturer's specification. When using tire ballasting method, use approved manufacturer's tires and place the tires flush with the ground.

Immediately replace any drum, ballast or reflective sheeting that are torn, crushed, discolored or otherwise damaged.

F. Cones

Use reflective adhesive sheeting on all cones used between dusk and dawn. Use the same type of reflective sheeting on all cone collars installed at any one time during the life of the project. Do not use cones in the upstream taper of lane or shoulder closures for multilane roadways and use for no longer than 3 consecutive days.

Use ballasting methods in accordance with manufacturer's specification. Cones may be used on all facilities for daytime and nighttime work with speed limits at or below 55 mph. If used at night, the cones shall have adhesive reflective sheeting and shall meet the height requirements in the *Roadway Standard Drawings*.

Cones may be used instead of drums, where allowed in the TMP plans or by the Engineer, on facilities with speed limits above 55 mph, if both the work is performed during daylight conditions and the devices are removed after each work period. Drums shall be used in the tapers.

The maximum spacing for cones on multi-lane roadways is equal in feet to the posted speed limit.

◆ **Revision No. 1, April 10, 2017 – This document supersedes version originally issued and sealed by J. Todd Brooks, NCPE No. 017586 on 12/28/2016.**

U-4715B**ITS-56****Buncombe County**

Immediately replace any cone that is torn, crushed, discolored or otherwise damaged.

G. Barricades

At the end of the workday, properly close the road where construction equipment accesses a road closure through Type III barricades.

Use sandbags or other approved ballasting methods to prevent overturning of barricades by the wind. If needed, place sandbags or other acceptable ballasting on the feet of the frame. Do not ballast barricades with objects such as rocks or chunks of concrete.

Do not anchor barricades to any pavement surfaces unless such anchoring method has passed the crash test requirement of NCHRP 350 for work zone category II devices.

Point the striped diagonals on the barricade rails in the direction of traffic flow.

H. Flaggers

Provide the service of properly equipped and qualified flaggers (see *Roadway Standard Drawings* No. 1150.01) at locations and times for such period as necessary for the control and protection of vehicular and pedestrian traffic. Anyone who controls traffic is required to be qualified. Qualification consists of each flagger receiving proper training in the set-up and techniques of safely and competently performing a flagging operation. Qualification of flaggers is to be done by an NCDOT approved training agency or other approved training provider. For a complete listing of these, see the Work Zone Traffic Control's webpage.

Prior to beginning work on the project, a Qualification Statement that all flaggers used on the project have been properly trained through an NCDOT approved training resource shall be provided to the Engineer.

Use flagging methods that comply with the guidelines in the MUTCD.

I. Truck Mounted Attenuator

Before use, furnish the Engineer detailed brochures, specifications, and other manufacturer's data that completely describes the performance criteria, installation, and instructions for the TMA.

Use only TMAs that meet the crash test requirements of *Standard Specifications* Article 1089-9(A).

Do not park TMAs against rigid objects (i.e. bridge piers or portable concrete barrier) except as a temporary safety measure and in no case for longer than 72 hours. Install the TMA on a truck that is fully operational, in good running order, and in accordance with the manufacturer's specifications.

Use the appropriate lighting and delineation on the truck and TMAs as shown in the contract.

Repair or replace within 24 hours any attenuator that becomes crushed or otherwise damaged so that it will perform its intended purpose. Suspend all construction activities until the attenuator is repaired or replaced. Provide safe control of traffic until the attenuator has been repaired by using approved methods.

◆ **Revision No. 1, April 10, 2017 – This document supersedes version originally issued and sealed by J. Todd Brooks, NCPE No. 017586 on 12/28/2016.**

J. Skinny Drums

Use the same type of reflective sheeting (Type III High Intensity Prismatic or greater) on all skinny drums installed at any one time during the life of the project. Use ballasting methods in accordance with the manufacturer's specification.

Immediately replace any skinny drum, ballast or reflective sheeting that are torn, crushed, discolored or otherwise damaged.

Skinny drums may be used instead of cones on all facilities with speed limits of 55 mph and below. Spacing of these devices is equal in feet to the speed limit in the taper and twice the speed limit or every other skip in the tangent sections.

Skinny drums may be used instead of cones and drums where allowed in the TMP or by the Engineer on facilities with speed limits above 55 mph, if all the following apply:

- 1) The work is performed during daylight conditions,
- 2) The devices are removed after each work period and
- 3) Drums are used in the tapers.

Do not use skinny drums on control-of-access facilities with speed limits above 55 mph that either involve night work or allow devices to remain in place overnight.

Do not use skinny drums for tapers on multilane or control-of-access roadways with speed limits above 55 mph.

Do not intermix with drums or cones unless directed by the Engineer or the TMP.

K. Law Enforcement

Use uniformed law enforcement officers and marked law enforcement vehicles equipped with blue lights mounted on top of the vehicle and law enforcement vehicle emblems to direct or control traffic as required by the Plans or by the Engineer.

Use a law enforcement officer(s) when an existing traffic signal must be taken out of operation in order to remove and replace the existing cabinet and controller. Use a law enforcement officer(s) when a traffic signal must be deactivated while constructing a conduit entrance into an existing cabinet foundation (subject to the Engineer's prior approval), while overlaying an existing cabinet foundation with a new preformed foundation and while removing and replacing an existing foundation with a new preformed foundation in the same location.

L. Pedestrian Safety

Install measures for separating pedestrian traffic from the work area and from adjacent vehicular traffic where pedestrian paths are evident or sidewalks are present. Use protective barricades, warning and guidance devices and signs to provide a safe, well-defined passageway for pedestrians. When a sidewalk must be closed temporarily to perform construction work, refer to Chapter 6D, "Pedestrian and Worker Safety," and Typical Applications 28 and 29 (TA-28 and TA-29) of the 2009 Edition of the *Manual on Uniform Traffic Control Devices* (MUTCD 2009) for appropriate pedestrian traffic control measures. The MUTCD 2009 is available online at the following web address: <http://mutcd.fhwa.dot.gov>

◆ **Revision No. 1, April 10, 2017 – This document supersedes version originally issued and sealed by J. Todd Brooks, NCPE No. 017586 on 12/28/2016.**

2.5. MAINTENANCE AND INSPECTION

A. Work Zone Traffic Control Devices

Submit a proposed traffic control device maintenance schedule and checklist for approval prior to construction. Perform continuous maintenance and scheduled inspections of traffic control devices. Review and maintain all traffic handling measures to ensure that adequate provisions are in place for the safety of the public and workers.

Maintenance activities include cleaning, repair or replacement of temporary traffic control devices that are damaged, torn, crushed, discolored, displaced or deteriorated beyond effectiveness.

If there are traffic control devices in use, perform inspection on a daily basis.

If the name and telephone number of the agency, Contractor or supplier is shown on the non-retroreflective surface of all channelizing devices, use letters and numbers that are a non-reflective color and not over 2 inches in height.

2.6. FAILURE TO MAINTAIN TRAFFIC CONTROL

Failure to maintain temporary traffic control measures and traffic control devices in accordance with this Project Special Provision may result in formal notification of noncompliance. Implement remedial action immediately for imminent danger situations as directed. Implement remedial action within 48 hours after notification of a safety issue that is not an imminent danger situation. See Articles 107-21 and 108-7 of the *Standard Specifications*.

Failure to comply may result in having the work performed with available forces and equipment. In cases of willful disregard for the safety of the public, the Engineer may proceed immediately to implement the measures necessary to provide the appropriate level of traffic control to ensure that the safety of all concerned parties is maintained.

2.7. MEASUREMENT AND PAYMENT

Nominal dimensions will be used to compute sign panel areas.

Work zone signs (barricade mounted) will be measured and paid for as the actual number of square feet satisfactorily installed on barricades and accepted by the Engineer. Payment will be made for the initial installation only. Relocation of signs will be considered incidental to the measurement of the quantity of signs.

Work zone signs (portable) will be measured and paid for as the actual number of square feet satisfactorily installed and accepted by the Engineer. Payment will be made for the initial installation only. Relocation of signs will be considered incidental to the measurement of the quantity of signs.

No direct payment will be made for portable work zone sign stands. All portable work zone sign stands will be incidental to the work of providing work zone signs.

Flashing arrow board will be measured and paid for as the maximum number of boards that have been satisfactorily placed and accepted by the Engineer in use at any one time during the life of the project as required by the contract. Relocation, repair, replacement and maintenance of arrow boards is considered incidental to the work of this section of the Project Special Provisions.

◆ **Revision No. 1, April 10, 2017 – This document supersedes version originally issued and sealed by J. Todd Brooks, NCPE No. 017586 on 12/28/2016.**

U-4715B

ITS-59

Buncombe County

Portable changeable message sign will be measured and paid for as the maximum number of portable changeable message signs acceptably placed and in operation, at any one time during the life of the project. Payment for *portable changeable message sign* will be made on the following schedule:

- 70% of the unit bid upon placing the unit in service.
- 20% of the unit bid when the project is 50% complete.
- 10% of the unit bid when the project is 100% complete.

Relocation, replacement, repair and maintenance of portable changeable message signs is considered incidental to the work of this section of the Project Special Provisions.

Drums will be measured and paid for as the maximum number of drums acceptably placed and in use at any one time during the life of the project. Relocation, repair, replacement and maintenance of cones will be incidental to the work of this section of the Project Special Provisions.

Cones will be measured and paid for as the maximum number of cones acceptably placed and in use at any one time during the life of the project. Relocation, repair, replacement and maintenance of cones will be incidental to the work of this section of the Project Special Provisions.

Barricades (Type III) will be measured and paid for as the maximum number of linear feet of barricades acceptably placed and in use at any one time during the life of the project. Measurement will be made of the total length of each barricade along one rail. Relocation, repair, replacement and maintenance of barricades will be incidental to the work of this section of the Project Special Provisions.

Flagger (hour) will be measured and paid for as the actual number of hours that each flagger is satisfactorily provided and accepted by the Engineer during the life of the project. Flagging conducted for the convenience of the Contractor's operations is not compensated. The Department will pay for flaggers, including those used at Y-lines that are used in conjunction with a lane closure. Flaggers used for operations not involving a lane closure will be incidental to that operation and no payment will be made. Flaggers used for hauling operations, where the only need for a lane closure is due to the hauling operation, will be incidental to that operation and no payment will be made. Any flagger used for less than one hour will be incidental to that operation.

TMA will be measured and paid for as the maximum number of TMAs acceptably placed and in use at any one time during the life of the project for all operations other than moving and mobile operations. TMAs will be incidental to all moving and mobile operations. In the case of emergency situations, TMAs will not be paid for when payment has already been made for a stationary unit. Relocation of TMAs will be incidental to the measurement of the quantities of TMAs and no separate payment will be made.

Skinny drum will be measured and paid for as the actual number of skinny drums satisfactorily placed, accepted by the Engineer and in use at any one time during the life of the project. Relocation, repair, replacement and maintenance of skinny drums is considered incidental to the work of this section of the Project Special Provisions.

◆ **Revision No. 1, April 10, 2017 – This document supersedes version originally issued and sealed by J. Todd Brooks, NCPE No. 017586 on 12/28/2016.**

U-4715B**ITS-60****Buncombe County**

Law enforcement will be measured and paid for as the actual number of hours that each law enforcement officer is provided during the life of the project as approved by the Engineer and subject to the following conditions:

- Measurement and payment will not exceed 3 hours per police officer provided to direct traffic at a given signalized intersection during the removal and replacement of a controller cabinet.
- Measurement and payment will not exceed 1 hour per police officer provided to direct traffic at a given signalized intersection while constructing a new conduit entrance into an existing cabinet foundation, overlaying an existing cabinet foundation with a new preformed foundation or replacing an existing foundation with a new preformed foundation in the same location.

There will be no direct payment for marked law enforcement vehicles as they are considered incidental to the pay item.

No measurement will be made of orange plastic mesh construction fencing or other approved methods of protecting open excavations/hazards from pedestrian intrusion as such measures will be considered incidental to the excavation work. No measurement will be made of temporary pedestrian footpaths required to maintain pedestrian movement around removed sections of sidewalk as such measures will be considered incidental to the excavation work and the replacement of the removed section of sidewalk.

If the Contractor fails to maintain acceptable traffic control measures or temporary traffic control devices and the Engineer implements measures necessary to provide the appropriate level of traffic control, the actual cost of performing said work will be deducted from the monies due the Contractor on the contract.

Payment will be made under:

| Pay Item | Pay Unit |
|--------------------------------------|-----------------|
| Work Zones Signs (Barricade Mounted) | Square Foot |
| Work Zones Signs (Portable) | Square Foot |
| Flashing Arrow Board | Each |
| Portable Changeable Message Sign | Each |
| Drums | Each |
| Cones | Each |
| Barricades (Type III) | Linear Foot |
| Flagger | Hour |
| TMA | Each |
| Skinny Drum | Each |
| Law Enforcement | Hour |

◆ **Revision No. 1, April 10, 2017 – This document supersedes version originally issued and sealed by J. Todd Brooks, NCPE No. 017586 on 12/28/2016.**

3. PAVEMENT MARKINGS

3.1. DESCRIPTION

Furnish and install pavement markings in accordance with the traffic signal plans. Remove existing pavement markings in accordance with the traffic signal plans.

3.2. MATERIALS

A. General

Refer to and fully comply with Section 1087 of the *Standard Specifications*.

B. Material Qualification

Use pavement markings which are on the Department's Approved Products List or are traffic qualified by the Signing and Delineation Unit.

C. Historical Performance

Historical performance of the pavement marking material will be used in determining future use of the material by the Department, even if material has been traffic qualified. Poor past or poor current performance of pavement marking material at any site, whether or not related to a specific contract may be grounds for non-acceptance of a product on any project under contract.

3.3. CONSTRUCTION METHODS

A. General

Refer to and fully comply with Section 1205 of the *Standard Specifications*.

Do not use handliners or any other non-truck mounted pavement marking machine to install pavement markings for long line applications of any one line longer than 1000 feet.

B. Testing Procedures

All pavement marking materials and placement will be tested by the Department. Install pavement markings in order to meet the retroreflectivity requirements as measured by a Department approved 30 m mobile or handheld retroreflectometer.

C. Application Equipment

(1) General for all Application Equipment

Use pavement marking application equipment such that all parts that come in contact with pavement marking material are constructed for easy accessibility during cleaning and maintenance.

Keep the marking guns of the application device in full view of the operators at all times. Use applicators that are mobile and maneuverable to the extent that straight lines can be followed and all standard curves can be made in true arcs.

(2) Glass Bead/Element Dispensing Equipment

Apply drop-on beads/elements to the surface of pavement long line markings using an automatic high pressurized bead dispenser or a pressurized mechanical feed, attached to the marking equipment. Hand liner type equipment is exempt from this

◆ **Revision No. 1, April 10, 2017 – This document supersedes version originally issued and sealed by J. Todd Brooks, NCPE No. 017586 on 12/28/2016.**

requirement. Locate the bead/element applicator at the proper distance behind the application of pavement marking material to provide the proper amount of retroreflectivity. Equip the bead applicator with an automatic cut-off control synchronized with the cut-off control of the marking material.

Spread the beads/elements uniformly over the entire surface of the pavement marking material such that they are partially embedded in the pavement marking. A 60% bead embedment depth provides optimum retroreflectivity.

D. Weather Limitations and Seasonal Limitations

Do not place pavement markings when moisture tests conducted on the pavement show signs of moisture presence on the pavement, or it is anticipated that damage causing moisture may occur during the installation and drying periods.

E. Time Limitations for Replacement

| TIME LIMIT FOR REPLACEMENT | | |
|--|--|---|
| Facility Type | Marking Type | Replacement Deadline |
| Full-control-of-access multi-lane roadway (4 or more total lanes) and ramps, including Interstates | All markings | By the end of each workday's operation if the lane is opened to traffic |
| Multi-lane roadways (3 or more lanes) and ramps | Center Line, Lane Line, Railroad symbols, Stop bars and school symbols | By the end of each workday's operation if the lane is opened to traffic (temporary paint may be used) |
| | Edge Lines, gore lines and all other symbols | By the end of the 3rd calendar after obliteration |
| Two-lane, two-way roadways | All centerline markings, railroad, Stop bars and school symbols | By the end of the 5th calendar day after obliteration |
| | Edge Lines and all other symbols | By the end of the 15th calendar day after obliteration |

A multilane facility is defined as any roadway having more than two lanes to include a two-lane / two-way roadway with a center two-way left turn lane.

F. Premarking/Interim/Temporary Markings

Premarking (or layout markings) are small paint spots used by striping contractors to establish locations of pavement markings. Premark each installation of the final pavement marking materials before application on new pavement and when required to replace existing pavement marking, except when existing markings are visible. Get the premarking inspected and approved by the Engineer before placing the pavement marking materials.

Interim paint is a thin layer of pavement marking paint applied at the striping contractor's option to maintain traffic, instead of durable pavement markings. Apply interim paint to comply with time limitations for placement if final pavement markings cannot be placed. Interim

◆ **Revision No. 1, April 10, 2017 – This document supersedes version originally issued and sealed by J. Todd Brooks, NCPE No. 017586 on 12/28/2016.**

U-4715B

ITS-63

Buncombe County

markings shall be no more than 1/4" less than the specified line width of the existing markings. Place temporary paint markings for detours, lane shifts, milled surfaces and lifts of asphalt other than the final pavement surface.

Review and record the existing pavement markings before resurfacing and reestablish the new pavement markings using the record of existing markings in conjunction with the *Roadway Standard Drawings*, unless otherwise directed. Submit the record of existing pavement markings 7 calendar days before the obliteration of any pavement markings.

G. Surface Preparation and Curing Compound Removal

Prepare the pavement to accept pavement markings to insure maximum possible adhesion. Clean, seal and remove curing compound as necessary to insure that the markings adhere to the pavement. Obtain approval for all surface preparation methods before implementing.

Pavements shall be free of grease, oil, mud, dust, dirt, grass, loose gravel and other deleterious material, prior to applying pavement markings.

Prepare the pavement surface, including removal of curing compound, a minimum of 2" wider than the pavement markings to be placed, such that, an additional 1" of prepared area is on all sides of the pavement markings after they are applied.

Remove all curing compound and surface laitance on Portland cement concrete pavements where long-life pavement markings will be placed. Perform curing compound removal by high-pressure water blasting methods or grinding methods. Ensure that the surface is free of all residue, laitance and debris before applying the pavement marking. When surface preparation and curing compound removal operations are completed, blow the pavement surface clean by compressed air immediately before installing the pavement markings.

If required, apply a primer sealer to pavement surfaces before applying pavement marking material as recommended by the manufacturer. Apply primer sealer in a continuous film at least 2" wider than the pavement markings in such a way as to not cause any noticeable change in the appearance of the pavement markings.

Conduct all pavement surface preparation including curing compound removal in such a manner that the pavement or joint material is not damaged or left in a condition that will mislead or misdirect the motorist. Repair any damage caused to the pavement, or joint materials caused by surface preparation or the removal of curing compound by acceptable methods and at no additional cost to the Department.

Where pavement surface preparation results in obscuring existing pavement markings of a lane occupied by traffic, immediately remove the residue, including dust, by approved methods.

H. Application of Pavement Markings

(1) General for all types of Pavement Markings

Install pavement marking material that has a uniform thickness, a smooth surfaced cross section throughout its entire length, width and length not less than the dimensions specified in the traffic signal plans and that does not exceed the dimension by more than 1/2".

◆ **Revision No. 1, April 10, 2017 – This document supersedes version originally issued and sealed by J. Todd Brooks, NCPE No. 017586 on 12/28/2016.**

U-4715B

ITS-64

Buncombe County

Do not apply pavement marking materials over a longitudinal joint. See *Roadway Standard Drawing* No. 1205.01, Sheet 2 of 2 for details.

Install pavement marking lines that are straight or have uniform curvature and conform with the tangents, curves, and transitions as specified in the traffic signal plans.

Produce finished lines that have well defined edges and are free of horizontal fluctuations. Do not exceed 1/2" in lateral deviation from the proposed location alignment at any point. Any greater deviations may be cause for requiring the material to be removed and replaced at no additional cost.

Apply all longitudinal pavement marking lines 8" or less in width with one pass of the pavement marking equipment. Pavement marking lines greater than 8" in width and pavement marking symbols may be applied with multiple passes of the pavement marking equipment

Install all pavement marking lines, characters, and symbols that require multiple passes of the application equipment such that there are no gaps separating the application passes.

Install characters and symbols so that they conform to the sizes and shapes shown in the traffic signal plans.

Protect the pavement markings until they are track free. Repair any markings tracked by a vehicle by acceptable methods.

Remove all pavement marking materials spilled on the road surface by acceptable methods.

Use yellow, white, and black pavement markings, without drop-on glass beads that visually match the color chips that correspond to the Federal Test Standard Number 595a for the following colors. Use markings that when subjected to accelerated weathering as described in U.S. Federal Specification No. (TT-P-115F) are within the tolerance limits of the color chips listed below:

White: Color 17886
 Yellow: Color 13538
 Black: Color 37038

(2) Glass Bead/Element Application

“Drop-on” is the method where glass beads are dispensed by a pressurized mechanical feed or high pressure means onto the pavement marking as it is applied to the pavement. Drop-on bead dispensing for symbols stop bars and characters may be accomplished by gravitational methods.

I. Pavement Markings Observation Period

This pavement markings observation period shall be a separate entity than the signal system observation period defined in these Project Special Provisions.

Maintain responsibility for the pavement markings for a 12-month observation period beginning upon the satisfactory completion and acceptance by the Engineer of all pavement

◆ **Revision No. 1, April 10, 2017 – This document supersedes version originally issued and sealed by J. Todd Brooks, NCPE No. 017586 on 12/28/2016.**

U-4715B**ITS-65****Buncombe County**

marking work required in the traffic signal plans. Guarantee the markings under the payment and performance bond in accordance with Article 105-17 of the *Standard Specifications*.

During the 12-month pavement marking (PM) observation period, provide pavement marking material that shows no signs of failure due to blistering, chipping, bleeding, discoloration, smearing or spreading under heat or poor adhesion to the pavement materials. Pavement markings that bonded during application and were approved, but debond due to snowplowing will be considered a failed marking. Replace, at no additional expense to the Department, any pavement markings that do not perform satisfactorily under traffic during the 12-month PM observation period.

J. Removal of Pavement Markings

This work includes the removal of all types of pavement marking lines, symbols, and characters including removal for long life marking preparation. This work does not include removal of removable tape pavement markings.

Remove pavement marking lines, characters, and symbols by acceptable methods to the Engineer that will not materially or structurally damage the surface or the texture of the pavement. Leave the pavement surface in a condition that will not mislead or misdirect the motorist.

Where existing pavement markings are to be removed and replaced by other pavement markings, do not begin removal until adequate provisions have been made to complete the installation of the replacement markings. Remove pavement markings such that the surface is in proper condition for adequate bonding of the new markings. Promptly remove any material deposited on the pavement as a result of removing pavement markings as the work progresses by acceptable methods. Provide the equipment necessary to control dust and the accumulation of debris resulting from the removal process. The removal equipment shall provide dust control and the capture of the removed material shall be done utilizing a separate vacuum equipped vehicle or other approved system. Perform the recovery process within the same operation as the removal. Do not let traffic use the lane where the removal is taking place until the recovery system is finished. Should the recovery system fail, cease removal operations until the recovery system is properly operating. The Contractor is responsible for all cleanup and proper disposal of all removed debris from the project site.

When using a grinding method for pavement removal, the equipment shall have multiple heads working in tandem to provide adequate preparation of the surface to accept the new marking material.

Do not apply polyurea pavement markings over existing pavement marking materials. Polyurea may be installed over existing polyurea only on asphalt as long as the existing polyurea is bonded. Application over all other existing pavement marking materials will require the at least 95% of the existing pavement marking material to be removed. However, if one 15 mil application of paint was placed on asphalt pavement less than 6 months old, do not remove the existing paint pavement markings.

Do not apply thermoplastic pavement markings over existing pavement marking materials. Thermoplastic may be installed over existing thermoplastic on asphalt. Application over existing pavement marking materials other than thermoplastic will require the existing pavement marking material to be removed so that a minimum of 85% of the existing pavement marking surface is

◆ **Revision No. 1, April 10, 2017 – This document supersedes version originally issued and sealed by J. Todd Brooks, NCPE No. 017586 on 12/28/2016.**

U-4715B**ITS-66****Buncombe County**

removed. Before applying thermoplastic pavement markings over the existing thermoplastic pavement markings, remove at least 25% of the oxidized existing thermoplastic. However, if one 15 mil application of paint was placed on asphalt less than 6 months old, do not remove the existing paint pavement markings.

Use black color #37038 in paint or tape, as determined by Contractor, to cover any remaining conflicting pavement marking after removal from asphalt pavement surfaces. Do not use black paint or tape on concrete pavement surfaces. The black paint will not have a defined shape or edges with a width not exceeding double of the existing lines.

K. Pavement Marking Installer Qualifications

Ensure at least one member of every pavement marking crew certified through the NCDOT Pavement Marking Technician Certification Process. Keep the certification current throughout the life of the project. A certified crewmember shall be present anytime this work is being performed. The certified crewmember is not required to be the same person throughout the life of the contract.

3.4. THERMOPLASTIC (ALKYD/MALEIC)

A. Application Equipment

(1) General

Use equipment to install hot thermoplastic pavement marking material that includes the following features: Use application equipment constructed to assure continuous uniformity in the thickness and width of the thermoplastic pavement marking. Use application equipment that provides multiple width settings ranging from 4" to 12" and multiple thickness settings to achieve the pavement marking thickness ranging from 0.090" to 0.120". Special thickness equipment may be required for in lane or shoulder transverse rumble strip pavement markings.

Do not use spray thermoplastic unless approved by the Signing and Delineation Unit.

(2) Premelting Kettle:

Use equipment to install hot thermoplastic pavement marking material that includes an oil-jacketed or air-jacketed premelt kettle for uniform heating and melting of the thermoplastic material. Use a kettle that is equipped with an automatic thermostat control device to provide positive temperature control and continuous mixing and agitation of the thermoplastic material. Do not premelt thermoplastic material in handliner type equipment.

(3) Applicator Storage Kettle

Equip long line pavement marking vehicles with an automatic thermostat control device to maintain the thermoplastic material at the application temperature and provide continuous mixing and agitation of the thermoplastic material during installation. Construct the equipment so that all mixing and conveying parts, up to and including the application apparatus, maintains the thermoplastic pavement marking material at the specified installation temperature and which has a capacity of a minimum of 1500 lbs. of molten thermoplastic pavement marking material. Hand transfer is not allowed.

◆ **Revision No. 1, April 10, 2017 – This document supersedes version originally issued and sealed by J. Todd Brooks, NCPE No. 017586 on 12/28/2016.**

U-4715B

ITS-67

Buncombe County

Hand Liner type application vehicles may contain the premelting and applicator storage functions in the same kettle. Agitation and mixing can be done manually. Drag box type and bucket type application is not allowed.

Use premelting and applicator storage kettles that meet the requirements of the National Board of Fire Underwriters, the National Fire Protection Association, and State and local authorities.

B. Weather Limitations and Seasonal Limitations

Do not apply thermoplastic pavement markings on existing or new pavements unless the ambient air temperature and the temperature of the pavement is 50°F or higher.

Do not apply thermoplastic pavement markings between November 15 and the following April 30.

Exception to the above: When traffic is maintained on a portion of roadway and thermoplastic pavement marking will not be placed within 30 calendar days due to seasonal limitations, place pavement marking paint and beads in accordance with Subarticle 1205-8(C) of the *Standard Specifications*.

C. Application

Use only thermoplastic markings that are of the hot, machine applied type. Apply alkyd/maleic thermoplastic pavement markings by extrusion methods only. Extrusion may be accomplished using either conventional extrusion equipment or ribbon gun extrusion devices.

The stem portion of straight arrows shall be applied in a single pass and the stem portion of turn arrows is to be applied in no more than 2 passes of the application equipment. Arrowheads may be applied by multiple passes of the application equipment, not to exceed 3 passes.

Apply drop-on Beads uniformly to the surface of the molten thermoplastic material so that the beads are partially embedded and at a rate to immediately obtain the minimum reflectance values. Produce in place markings with the minimum retroreflective values shown in the table below, as obtained with a Department approved 30 m mobile or handheld retroreflectometer. Retroreflective measurements will be taken within 30 days after final placement of the pavement marking.

| REFLECTOMETER REQUIREMENTS FOR THERMOPLASTIC | | |
|---|--------------|----------------------------|
| Item | Color | Reflectivity |
| Standard Glass Beads | White | 375 mcd/lux/m ² |
| | Yellow | 250 mcd/lux/m ² |

Ensure that the marking is uniformly retroreflective upon cooling and has the ability to resist deformation caused by traffic throughout its entire length.

A thin layer of interim pavement marking paint at the proper width may be placed before installing the thermoplastic markings. If this option is chosen, when not specified in the Plans or by the Engineer, direct payment for the paint will not be made. Cover any such thin layer of pavement marking paint with thermoplastic pavement marking within 30 calendar days of placement. Apply the thin layer of pavement marking paint and beads at the rate necessary to

◆ **Revision No. 1, April 10, 2017 – This document supersedes version originally issued and sealed by J. Todd Brooks, NCPE No. 017586 on 12/28/2016.**

U-4715B

ITS-68

Buncombe County

produce a dry film thickness of 5 to 8 mils. Apply drop-on glass beads at a rate of 1 to 3 lbs/ gal of paint.

Provide drainage openings at intervals of 250 ft in edge lines placed on the inside of curves and in edge lines on the low side of tangents. Provide openings that are no more than 12" and at least 6" in length.

Produce a cross sectional thickness of the thermoplastic markings above the surface of the pavement in accordance with the table below.

| THICKNESS REQUIREMENT | |
|-----------------------|---|
| Thickness | Location |
| 240 mils | In-lane and shoulder-transverse pavement markings (rumble strips) may be placed in 2 passes. |
| 120 mils | Center lines, skip lines, transverse bands, mini-skip lines, characters, and crosswalk lines. |
| 90 mils | Edge lines, gore lines, diagonals, yield line symbols and arrow symbols. |

D. Thermoplastic Marking Observation Period

In addition to the requirements of "Pavement Markings Observation Period" subsection above, maintain responsibility for minimum retroreflective values for a 30-day period beginning upon the Engineer's acceptance of all markings on the Project. Guarantee retroreflective values of the markings during the 30-day period under the payment and performance bond in accordance with Article 105-17 of the *Standard Specifications*.

3.5. MAINTENANCE

Replace pavement markings that prematurely deteriorate, fail to adhere to the pavement, lack reflectorization, or are otherwise unsatisfactory, during the life of the project or during the 12-month pavement markings observation period as determined by the Engineer.

Upon notification from the Engineer, winterize the project by placing an initial or additional application of paint pavement marking lines in accordance with Article 1205-8 of the *Standard Specifications*.

3.6. MEASUREMENT AND PAYMENT

_____ *pavement marking lines* will be measured and paid as the actual number of linear feet of pavement marking lines satisfactorily placed and accepted by the Engineer. The quantity of solid lines will be the summation of the linear feet of solid line measured end-to-end of the line. The quantity of skip or broken lines will be the summation of the linear feet derived by multiplying the nominal length of a line by the number of markings satisfactorily placed.

Removal of pavement marking lines will be measured and paid as the actual number of linear feet of pavement marking lines satisfactorily removed and accepted by the Engineer. The quantity of solid lines will be the summation of the linear feet of solid line measured end-to-end of the line. The quantity of skip or broken lines will be the summation of the linear feet derived by multiplying the nominal length of a line by the number of marking lines satisfactorily removed. No payment will be made for the removal of removable pavement marking tape.

◆ **Revision No. 1, April 10, 2017 – This document supersedes version originally issued and sealed by J. Todd Brooks, NCPE No. 017586 on 12/28/2016.**

U-4715B**ITS-69****Buncombe County**

Payment at the contract unit price for the various items in the contract will be full compensation for all the items covered by this section. No direct payment will be made for: the work involved in applying the lines, including surface preparation; reapplication of molten pavement marking crossed by a vehicle; removal of all pavement marking materials spilled on the roadway surface; and repair of markings tracked by a vehicle.

The Contractor may choose to use heated-in-place thermoplastic symbols, characters and transverse lines instead of molten thermoplastics pavement markings at no additional cost to the Department.

Replacement of pavement markings that prematurely deteriorated, failed to adhere to the pavement, lacked reflectorization or were otherwise unsatisfactory during the life of the project or during the 12-month pavement markings observation period as determined by the Engineer will be at no cost to the Department.

Payment will be made under:

| Pay Item | Pay Unit |
|--|-----------------|
| Thermoplastic Pavement Marking Lines (8", 120 mils) | Linear Foot |
| Thermoplastic Pavement Marking Lines (24", 120 mils) | Linear Foot |
| Removal of Pavement Marking Lines (24") | Linear Foot |

◆ **Revision No. 1, April 10, 2017 – This document supersedes version originally issued and sealed by J. Todd Brooks, NCPE No. 017586 on 12/28/2016.**

U-4715B

ITS-70

Buncombe County

4. SIGNAL HEADS

4.1. DESCRIPTION

Furnish, install vehicle LED signal heads, visors, interconnecting brackets, wire entrance fittings, mounting assemblies, signal cable, lashing wire, grounding systems, and all necessary hardware.

4.2. MATERIALS

A. General

Furnish material, equipment and hardware under this section that is pre-approved on the ITS and Signals QPL.

Fabricate vehicle signal head housings and end caps from die-cast aluminum. Fabricate 12-inch and 16-inch pedestrian signal head housings and end caps from die-cast aluminum. Fabricate 9-inch pedestrian signal head housings, end caps, and visors from virgin polycarbonate material. Provide visor mounting screws, door latches, and hinge pins fabricated from stainless steel. Provide interior screws, fasteners, and metal parts fabricated from stainless steel or corrosion resistant material.

Fabricate tunnel and traditional visors from sheet aluminum.

Fabricate tunnel and traditional visors for vehicle signal heads from ultraviolet and heat-stabilized virgin polycarbonate material. Fabricate tunnel and traditional visors for pedestrian signal heads from sheet aluminum.

Paint all surfaces inside and outside of signal housings and doors. Paint outside surfaces of tunnel and traditional visors, messenger cable mounting assemblies, pole and pedestal mounting assemblies, and pedestrian pushbutton housings. Have electrostatically-applied, fused-polyester paint in highway yellow (Federal Standard 595C, Color Chip Number 13538) a minimum of 2.5 to 3.5 mils thick. Do not apply paint to the latching hardware or rigid vehicle signal head mounting brackets for mast arm attachments, messenger cable hanger components or balance adjuster components.

Paint the signal housings and visors black (Federal Standard 595C, Color Chip Number 17038) when the existing pedestrian and vehicle signals at the intersection where the new signals will be installed are painted black.

Paint the signal housings and visors dark olive green (Federal Standard 595C, Color Chip Number 14056 or City of Asheville approved dark olive green color) when:

- The vehicle signal will be mounted on metal poles or mast arms that currently have a either a black or dark green finish.
- The existing pedestrian and vehicle signals at the intersection where the new signals will be installed are painted dark green.

For signals at all other locations, paint the signal housings highway yellow (Federal Standard 595C, Color Chip Number 13538).

◆ **Revision No. 1, April 10, 2017 – This document supersedes version originally issued and sealed by J. Todd Brooks, NCPE No. 017586 on 12/28/2016.**

U-4715B**ITS-71****Buncombe County**

Have the interior surfaces of tunnel and traditional visors painted an alkyd urea black synthetic baking enamel with a minimum gloss reflectance and meeting the requirements of MIL-E-10169, "Enamel Heat Resisting, Instrument Black."

For pole mounting, provide side of pole mounting assemblies with framework and all other hardware necessary to make complete, watertight connections of the signal heads to the poles and pedestals. Fabricate the mounting assemblies and frames from aluminum with all necessary hardware, screws, washers, etc. to be stainless steel. Provide mounting fittings that match the positive locking device on the signal head with the serrations integrally cast into the brackets. Provide upper and lower pole plates that have a 1¼-inch vertical conduit entrance hubs with the hubs capped on the lower plate and 1½-inch horizontal hubs. Ensure that the assemblies provide rigid attachments to poles and pedestals so as to allow no twisting or swaying of the signal heads. Ensure that all raceways are free of sharp edges and protrusions, and can accommodate a minimum of ten Number 14 AWG conductors.

For pedestal mounting, provide a post-top slipfitter mounting assembly that matches the positive locking device on the signal head with serrations integrally cast into the slipfitter. Provide stainless steel hardware, screws, washers, etc. Provide a minimum of six 3/8 X 3/4-inch long square head bolts for attachment to pedestal. Provide a center post for multi-way slipfitters. Furnish post-top slipfitter mounting assemblies that are either the same color as the housing of the pedestrian or vehicle signal head that will be attached to them (e.g., furnish black assemblies for black signal heads, dark green assemblies for dark green signal heads and yellow assemblies for yellow signal heads) or which have a natural aluminum finish. Comply with the painting requirements for signal heads listed above.

For light emitting diode (LED) traffic signal modules, provide the following requirements for inclusion on the Department's Qualified Products List (QPL) for traffic signal equipment.

1. Sample submittal,
2. Third-party independent laboratory testing results for each submitted module with evidence of testing and conformance with all of the Design Qualification Testing specified in Section 6.4 of each of the following Institute of Transportation Engineers (ITE) specifications:
 - Vehicle Traffic Control Signal Heads – Light Emitting Diode (LED) Circular Signal Supplement
 - Vehicle Traffic Control Signal Heads – Light Emitting Diode (LED) Vehicle Arrow Traffic Signal Supplement
 - Pedestrian Traffic Control Signal Indications – Light Emitting Diode (LED) Pedestrian Traffic Signal Modules.

(Note: The Department currently recognizes two approved independent testing laboratories. They are Intertek ETL Semko and Light Metrics, Incorporated with Garwood Laboratories. Independent laboratory tests from other laboratories may be considered as part of the QPL submittal at the discretion of the Department.)

3. Evidence of conformance with the requirements of these specifications,
4. A manufacturer's warranty statement in accordance with the required warranty, and
5. Submittal of manufacturer's design and production documentation for the model, including but not limited to, electrical schematics, electronic component values,

◆ **Revision No. 1, April 10, 2017 – This document supersedes version originally issued and sealed by J. Todd Brooks, NCPE No. 017586 on 12/28/2016.**

proprietary part numbers, bill of materials, and production electrical and photometric test parameters,

6. Evidence of approval of the product to bear the Intertek ETL Verified product label for LED traffic signal modules.

In addition to meeting the performance requirements for the minimum period of 60 months, provide a written warranty against defects in materials and workmanship for the modules for a period of 60 months after installation of the modules. During the warranty period, the manufacturer must provide replacement modules within 45 days of receipt of modules that have failed at no cost to the State or City. Repaired or refurbished modules may not be used to fulfill the manufacturer's warranty obligations. Provide manufacturer's warranty documentation to the Department during evaluation of product for inclusion on the ITS and Signals QPL.

B. Vehicle Signal Heads

Comply with the ITE standard "Vehicle Traffic Control Signal Heads." Provide housings with provisions for attaching backplates.

Provide visors that are 8 inches in length for 8-inch vehicle signal head sections. Provide visors that are 10 inches in length for 12-inch vehicle signal heads.

Provide a termination block with one empty terminal for field wiring for each indication plus one empty terminal for the neutral conductor. Have all signal sections wired to the termination block. Provide barriers between the terminals that have terminal screws with a minimum Number 8 thread size and that will accommodate and secure spade lugs sized for a Number 10 terminal screw.

Mount termination blocks in the yellow signal head sections on all in-line vehicle signal heads. Mount the termination block in the red section on five-section vehicle signal heads.

Furnish vehicle signal head interconnecting brackets. Provide one-piece aluminum brackets less than 4.5 inches in height and with no threaded pipe connections. Provide hand holes on the bottom of the brackets to aid in installing wires to the signal heads. Lower brackets that carry no wires and are used only for connecting the bottom signal sections together may be flat in construction.

For messenger cable mounting, provide messenger cable hangers, wire outlet bodies, balance adjusters, bottom caps, wire entrance fitting brackets, and all other hardware necessary to make complete, watertight connections of the vehicle signal heads to the messenger cable. Fabricate mounting assemblies from malleable iron and provide serrated rings made of aluminum. Provide messenger cable hangers and balance adjusters that are galvanized before being painted. Fabricate balance adjuster eyebolt and eyebolt nut from stainless steel or galvanized malleable iron. Provide messenger cable hangers with U-bolt clamps. Fabricate washers, screws, bolts, clevis pins, cotter pins, nuts, and U-bolt clamps from stainless steel.

For mast arm mounting, provide rigid vehicle signal head mounting brackets and all other hardware necessary to make complete, watertight connections of the vehicle signal heads to the mast arms and to provide a means for vertically adjusting the vehicle signal heads to proper alignment. Fabricate the mounting assemblies from malleable iron or aluminum, and provide serrated rings made of aluminum. Provide stainless steel cable attachment assemblies to secure the brackets to the mast arms. Ensure all fastening hardware and fasteners are fabricated from stainless steel.

◆ **Revision No. 1, April 10, 2017 – This document supersedes version originally issued and sealed by J. Todd Brooks, NCPE No. 017586 on 12/28/2016.**

U-4715B

ITS-73

Buncombe County

Provide LED vehicular traffic signal modules (hereafter referred to as modules) that consist of an assembly that uses LEDs as the light source in lieu of an incandescent lamp for use in traffic signal sections. Use LEDs that are aluminum indium gallium phosphorus (AlInGaP) technology for red and yellow indications and indium gallium nitride (InGaN) for green indications. Install the ultra bright type LEDs that are rated for 100,000 hours of continuous operation from -40°F to +165°F. Design modules to have a minimum useful life of 60 months and to meet all parameters of this specification during this period of useful life.

For the modules, provide spade terminals crimped to the lead wires and sized for a #10 screw connection to the existing terminal block in a standard signal head. Do not provide other types of crimped terminals with a spade adapter.

Ensure the power supply is integral to the module assembly. On the back of the module, permanently mark the date of manufacture (month & year) or some other method of identifying date of manufacture.

Tint the red, yellow and green lenses to correspond with the wavelength (chromaticity) of the LED. Transparent tinting films are unacceptable. Provide a lens that is integral to the unit with a smooth outer surface.

1. LED Circular Signal Modules:

Provide modules in the following configurations: 12-inch circular sections, and 8-inch circular sections. All makes and models of LED modules purchased for use on this project shall appear on the current NCDOT ITS & Signals QPL.

Provide the manufacturer's model number and the product number (assigned by the Department) for each module that appears on the 2012 or most recent ITS & Signals QPL. In addition, provide manufacturer's certification in accordance with Article 106-3 of the *Standard Specifications*, that each module meets or exceeds the ITE "Vehicle Traffic Control Signal Heads – Light Emitting Diode (LED) Circular Signal Supplement" dated June 27, 2005 (hereafter referred to as VTCSH Circular Supplement) and other requirements stated in this specification.

Provide modules that meet the following requirements when tested under the procedures outlined in the VTCSH Circular Supplement:

| Module Type | Max. Wattage at 165° F | Nominal Wattage at 77° F |
|------------------------|------------------------|--------------------------|
| 12-inch red circular | 17 | 11 |
| 8-inch red circular | 13 | 8 |
| 12-inch green circular | 15 | 15 |
| 8-inch green circular | 12 | 12 |

For yellow circular signal modules, provide modules tested under the procedures outlined in the VTCSH Circular Supplement to insure power required at 77° F is 22 Watts or less for the 12-inch circular module and 13 Watts or less for the 8-inch circular module.

Note: Use a wattmeter having an accuracy of ±1% to measure the nominal wattage and maximum wattage of a circular traffic signal module. Power may also be derived from voltage, current and power factor measurements.

◆ **Revision No. 1, April 10, 2017 – This document supersedes version originally issued and sealed by J. Todd Brooks, NCPE No. 017586 on 12/28/2016.**

2. LED Arrow Signal Modules

Provide 12-inch omnidirectional arrow signal modules. All makes and models of LED modules purchased for use on this project shall appear on the current NCDOT ITS & Signals QPL.

Provide the manufacturer's model number and the product number (assigned by the Department) for each module that appears on the 2012 or most recent ITS & Signals QPL. In addition, provide manufacturer's certification in accordance with Article 106-3 of the *Standard Specifications*, that each module meets or exceeds the requirements for 12-inch omnidirectional modules specified in the ITE "Vehicle Traffic Control Signal Heads – Light Emitting Diode (LED) Vehicle Arrow Traffic Signal Supplement" dated July 1, 2007 (hereafter referred to as VTCSH Arrow Supplement) and other requirements stated in this specification.

Provide modules that meet the following requirements when tested under the procedures outlined in the VTCSH Arrow Supplement:

| Module Type | Max. Wattage at 165° F | Nominal Wattage at 77° F |
|------------------------|------------------------|--------------------------|
| 12-inch red circular | 12 | 9 |
| 12-inch green circular | 11 | 11 |

For yellow arrow signal modules, provide modules tested under the procedures outlined in the VTCSH Arrow Supplement to insure power required at 77° F is 12 Watts or less.

Note: Use a wattmeter having an accuracy of $\pm 1\%$ to measure the nominal wattage and maximum wattage of an arrow traffic signal module. Power may also be derived from voltage, current and power factor measurements.

C. LED U-Turn Arrow Signal Modules:

Provide modules in the following configurations: 12-inch left u-turn arrow signal modules and 12-inch right u-turn arrow signal modules.

Modules are not required to be listed on the ITS and Signals Qualified Products List. Provide manufacturer's certification in accordance with Article 106-3 of the *Standard Specifications*, that each module meets or exceeds the ITE "Vehicle Traffic Control Signal Heads – Light Emitting Diode (LED) Circular Signal Supplement" dated June 27, 2005 (hereafter referred to as VTCSH Circular Supplement) and other requirements stated in this specification.

Provide modules that have minimum maintained luminous intensity values that are not less than 16% of the values calculated using the method described in section 4.1 of the VTCSH Circular Supplement.

Provide modules that meet the following requirements when tested under the procedures outlined in the VTCSH Circular Supplement:

| Module Type | Max. Wattage at 165° F | Nominal Wattage at 77° F |
|----------------------------|------------------------|--------------------------|
| 12-inch red u-turn arrow | 17 | 11 |
| 12-inch green u-turn arrow | 15 | 15 |

For yellow u-turn arrow signal modules, provide modules tested under the procedures outlined in the VTCSH Circular Supplement to ensure power required at 77° F is 22 Watts or less.

◆ **Revision No. 1, April 10, 2017 – This document supersedes version originally issued and sealed by J. Todd Brooks, NCPE No. 017586 on 12/28/2016.**

U-4715B**ITS-75****Buncombe County**

Note: Use a wattmeter having an accuracy of $\pm 1\%$ to measure the nominal wattage and maximum wattage of a circular traffic signal module. Power may also be derived from voltage, current and power factor measurements.

D. Pedestrian Signal Heads:

Provide pedestrian signal heads with international symbols that meet the MUTCD. Do not provide letter indications.

Comply with the ITE standard for “Pedestrian Traffic Control Signal Indications” and the following sections of the ITE standard for “Vehicle Traffic Control Signal Heads” in effect on the date of advertisement:

- Section 3.00 - “Physical and Mechanical Requirements”
- Section 4.01 - “Housing, Door, and Visor: General”
- Section 4.04 - “Housing, Door, and Visor: Materials and Fabrication”
- Section 7.00 - “Exterior Finish”

Provide a double-row termination block with three empty terminals and number 10 screws for field wiring. Provide barriers between the terminals that accommodate a spade lug sized for number 10 terminal screws. Mount the termination block in the hand section. Wire all signal sections to the terminal block.

Where required by the plans, provide 16-inch pedestrian signal heads with traditional three-sided, rectangular visors, 6 inches long. Where required by the plans, provide 12-inch pedestrian signal heads with traditional three-sided, rectangular visors, 8 inches long.

Provide 2-inch diameter pedestrian push-buttons with weather-tight housings fabricated from die-cast aluminum and threading in compliance with the NEC for rigid metal conduit. Provide a weep hole in the housing bottom and ensure that the unit is vandal resistant.

Provide push-button housings that are suitable for mounting on flat or curved surfaces and that will accept 1/2-inch conduit installed in the top. Provide units that have a heavy duty push-button assembly with a sturdy, momentary, normally-open switch. Have contacts that are electrically insulated from the housing and push-button. Ensure that the push-buttons are rated for a minimum of 5 mA at 24 volts DC and 250 mA at 12 volts AC.

Provide standard R10-3 signs with mounting hardware that comply with the MUTCD in effect on the date of advertisement. Provide R10-3E signs for countdown pedestrian heads and R10-3B for non-countdown pedestrian heads.

Design the LED pedestrian traffic signal modules (hereafter referred to as modules) for installation into standard pedestrian traffic signal sections that do not contain the incandescent signal section reflector, lens, eggcrate visor, gasket, or socket. Provide modules that consist of an assembly that uses LEDs as the light source in lieu of an incandescent lamp. Use LEDs that are of the latest aluminum indium gallium phosphorus (AlInGaP) technology for the Portland Orange hand and countdown displays. Use LEDs that are of the latest indium gallium nitride (InGaN) technology for the Lunar White walking man displays. Install the ultra-bright type LEDs that are rated for 100,000 hours of continuous operation from -40°F to $+165^{\circ}\text{F}$. Design modules to have a minimum useful life of 60 months and to meet all parameters of this specification during this period of useful life.

◆ **Revision No. 1, April 10, 2017 – This document supersedes version originally issued and sealed by J. Todd Brooks, NCPE No. 017586 on 12/28/2016.**

U-4715B**ITS-76****Buncombe County**

Design all modules to operate using a standard 3 - wire field installation. Provide spade terminals crimped to the lead wires and sized for a #10 screw connection to the existing terminal block in a standard pedestrian signal housing. Do not provide other types of crimped terminals with a spade adapter.

Ensure the power supply is integral to the module assembly. On the back of the module, permanently mark the date of manufacture (month & year) or some other method of identifying date of manufacture.

Provide modules in the following configuration: 16-inch displays which have the solid hand/walking man overlay on the left and the countdown on the right, and 12-inch displays which have the solid hand/walking man module as an overlay. All makes and models of LED modules purchased for use on the State Highway System shall appear on the current NCDOT Traffic Signal QPL.

Provide the manufacturer's model number and the product number (assigned by the Department) for each module that appears on the 2012 or most recent Qualified Products List. In addition, provide manufacturer's certification in accordance with Article 106-3 of the *Standard Specifications*, that each module meets or exceeds the ITE "Pedestrian Traffic Control Signal Indicators - Light Emitting Diode (LED) Signal Modules" dated August 04, 2010 (hereafter referred to as PTCSI Pedestrian Standard) and other requirements stated in this specification.

Provide modules that meet the following requirements when tested under the procedures outlined in the PTCSI Pedestrian Standard:

| Module Type | Max. Wattage at 165° F | Nominal Wattage at 77° F |
|------------------------|-------------------------------|---------------------------------|
| Hand Indication | 16 | 13 |
| Walking Man Indication | 12 | 9 |
| Countdown Indication | 16 | 13 |

Note: Use a wattmeter having an accuracy of $\pm 1\%$ to measure the nominal wattage and maximum wattage of a circular traffic signal module. Power may also be derived from voltage, current and power factor measurements.

Provide module lens that is hard coated or otherwise made to comply with the material exposure and weathering effects requirements of the Society of Automotive Engineers (SAE) J576. Ensure all exposed components of the module are suitable for prolonged exposure to the environment, without appreciable degradation that would interfere with function or appearance.

Ensure the countdown display continuously monitors the traffic controller to automatically learn the pedestrian phase time and update for subsequent changes to the pedestrian phase time.

Ensure the countdown display begins normal operation upon the completion of the preemption sequence and no more than one pedestrian clearance cycle.

E. Signal Cable

Furnish 16-4 and 16-7 signal cable that complies with IMSA specification 20-1 except provide the following conductor insulation colors:

- For 16-4 cable: white, yellow, red, and green;

◆ **Revision No. 1, April 10, 2017 – This document supersedes version originally issued and sealed by J. Todd Brooks, NCPE No. 017586 on 12/28/2016.**

U-4715B

ITS-77

Buncombe County

- For 16-7 cable: white, yellow, red, green, yellow with black stripe tracer, red with black stripe tracer, and green with black stripe tracer. Apply continuous stripe tracer on conductor insulation with a longitudinal or spiral pattern.

Provide a ripcord to allow the cable jacket to be opened without using a cutter. IMSA specification 19-1 will not be acceptable. Provide a cable jacket labeled with the IMSA specification number and provide conductors constructed of stranded copper.

4.3. CONSTRUCTION METHODS

A. General

Bag new vehicle signal heads with burlap bags or bags made of non-ripping material specifically designed for covering signal heads until signal heads are placed in operation. Do not use trash bags of any type.

When new signal heads are placed into operation, immediately bag and remove signals heads that are not to be reused.

Adjust each signal head vertically and horizontally so that light output will be of maximum effectiveness for traffic and pedestrians. Do not tilt signal heads forward.

B. Vehicle Signal Heads

Install vehicle signal heads such that the top of the signal housing located over any portion of a highway that can be used by motor vehicles is no more than 25.6 ft above the pavement.

Install vehicle signal heads such that the maximum mounting height to the top of the signal housing is as shown in the graph below if the location is between 40 ft and 53 ft from the stop line.

**Maximum Mounting Height of Signal Heads
Located Between 40 Feet and 53 Feet from Stop Line**

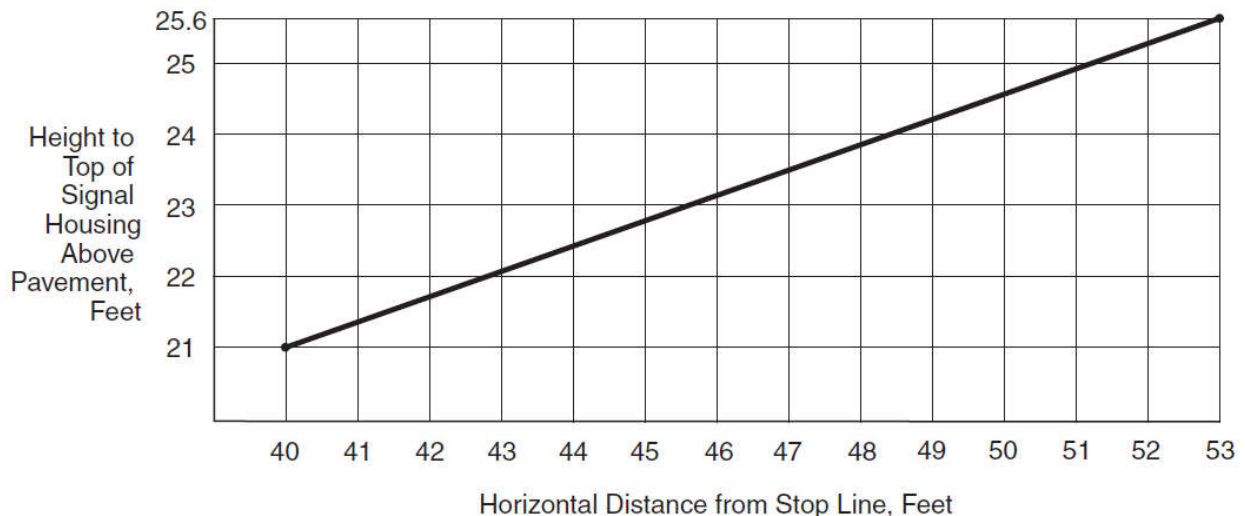

Graph of maximum mounting height of signal heads.

Install vehicle signal heads such that the bottom of the signal housing and any related attachments to the signal head located over any portion of a highway that can be used by motor

◆ **Revision No. 1, April 10, 2017 – This document supersedes version originally issued and sealed by J. Todd Brooks, NCPE No. 017586 on 12/28/2016.**

vehicles is at least 15 feet (preferably at least 16.5 feet) above the pavement directly below the signal head.

- 1) Install vehicle signal heads such that the bottom of the signal housing (including brackets) of a signal head that is vertically arranged and not located over a roadway is as follows:
 - (a) A minimum of 8 ft and a maximum of 19 ft above the sidewalk or, if there is no sidewalk, above the pavement grade at the center of the roadway.
 - (b) A minimum of 8 ft and a maximum of 19 ft above the median island grade of a center median island if located on the near side of the intersection.
- 2) Install vehicle signal heads such that the bottom of the signal housing (including brackets) of a signal head that is horizontally arranged and not located over a roadway is as follows:
 - (a) A minimum of 8 ft and a maximum of 22 ft above the sidewalk or, if there is no sidewalk, above the pavement grade at the center of the roadway.
 - (b) A minimum of 8 ft and a maximum of 22 ft above the median island grade of a center median island if located on the near side of the intersection.

Where vehicle signal heads are installed on messenger cable, install mounting hardware consisting of messenger cable hanger, balance adjuster, bottom cap, wire entrance fitting bracket, and insulating bushings.

Where vehicle signal heads are installed on mast arms, install mounting hardware consisting of rigid vehicle signal head mounting brackets.

Install signal cable in continuous lengths between signal controller cabinets and signal heads. Route signal cable to minimize the length of cable installed and the number of cables and conductors in each run. Pull 36 inches of additional signal cable into controller cabinets.

Wrap signal cable to messenger cable with at least 4 turns of wrapping tape spaced at intervals less than 15 inches or lash signal cable to messenger cable with one 360-degree spiral of lashing wire per 12 inches.

Make electrical connections inside each signal head, signal controller cabinet, and termination compartment in metal poles. Do not splice cable at any other point between signal heads and controller cabinet.

Coil sufficient signal cable beside each vehicle signal head to accommodate head shifts during various construction phases. For final signal head locations, coil 36 inches on each side of signal head if signal cable comes from both directions. If signal cable terminates at the signal head, coil 36 inches of signal cable on the same side as the cable run.

C. Pedestrian Signal Heads

Install signs with mounting hardware immediately above pedestrian pushbuttons.

Mount the pushbutton or pushbutton integrated accessible pedestrian signal (i.e., APS detector station) at a minimum height of 3.5 feet but no higher than 4.0 feet above the adjacent pedestrian travelway.

U-4715B**ITS-79****Buncombe County**

Connect each pushbutton with a separate run of lead-in cable between the pushbutton and the termination panel in the controller cabinet. Bond pushbutton housing and all metal components to cabinet ground using lead-in cable ground.

Mount pedestrian signal heads so that the bottom of the signal housing, including brackets, is not less than 7 feet or more than 10 feet above sidewalk level. Position and adjust the heads to provide maximum visibility at the beginning of the controlled crosswalk. Ensure pedestrian signal heads and vehicular signal heads mounted on the same support are physically separated from each other.

4.4. MEASUREMENT AND PAYMENT

Vehicle signal head (_____) and *pedestrian signal head* (_____) will be measured and paid for as the actual number of signal heads of each type, size, and number of sections furnished, installed, and accepted.

No measurement will be made of visors, wire entrance fittings, interconnecting brackets, mounting assemblies, painting of signal heads and visors, pedestrian pushbuttons, and pedestrian signal signs as these will be considered incidental to furnishing and installing vehicle and pedestrian signal heads.

½” risers with weatherheads for pedestrian pushbuttons will be measured and paid in accordance with the “Riser Assemblies” section of these Project Special Provision. Where the Plans call for installing a new pedestrian pushbutton with a new ½” riser with weatherhead, no measurement will be made of the pedestrian pushbutton as it will be considered incidental to furnishing and installing the ½” riser with weatherhead.

Signal cable will be measured and paid for as actual linear feet of signal cable furnished, installed, and accepted. Measurement will be point to point with no allowance for sag. Twenty-five feet will be allowed for vertical segments up or down poles.

No measurement will be made for drip loops, coiled sections, aluminum wrapping tape or lashing wire as these will be considered incidental to furnishing and installing signal cable.

Pushbutton integrated pedestrian signals will be measured and paid in accordance with the “Pushbutton Integrated Pedestrian Signal (APS)” section of these Project Special Provisions.

Payment will be made under:

| Pay Item | Pay Unit |
|---|-----------------|
| Vehicle Signal Head (12”, 3 Section) | Each |
| Vehicle Signal Head (12”, 4 Section) | Each |
| Vehicle Signal Head (12”, 5 Section) | Each |
| Pedestrian Signal Head (16”, 1 Section w/Countdown) | Each |
| Signal Cable | Linear Foot |

◆ **Revision No. 1, April 10, 2017 – This document supersedes version originally issued and sealed by J. Todd Brooks, NCPE No. 017586 on 12/28/2016.**

5. PUSHBUTTON INTEGRATED ACCESSIBLE PEDESTRIAN SIGNAL (APS)

5.1. DESCRIPTION

Furnish and install pushbutton integrated accessible pedestrian signals that include pedestrian pushbutton, pushbutton locator tone, raised tactile arrow, audio and vibro-tactile walk indications, automatic volume adjustment, pedestrian information sign, and all necessary hardware. Furnish the R10-3e sign with appropriate arrow direction for the pedestrian information sign.

5.2. MATERIALS

Furnish material, equipment, and hardware under this section that is pre-approved on the ITS and Signals QPL.

Provide the accessible pedestrian signals with a 2-inch diameter pedestrian push button that contains a tactile arrow whose direction can be easily adjusted in the field. Ensure each push button actuates a sturdy, momentary, normally-open switch with a minimum rating of 20 million actuations. Include on the button, a raised tactile arrow having a high visual contrast with the remainder of the button face. Ensure the housing is weather-tight and fabricated from aluminum. Ensure the housing is suitable for mounting on wood and metal poles. Paint surfaces of the pedestrian push button housing in highway yellow, unless otherwise specified, with an electrostatically-applied, fused-polyester paint method. Ensure the thickness of the paint is a minimum of 2.5 mils. Provide the pedestrian information sign that is integral to the housing.

Ensure the accessible pedestrian signals can provide tones, sounds, and speech messages that are synchronized at an intersection. Provide a means for adjusting the base sound level for the tones, sounds, and speech messages. Ensure the tones, sounds, and speech messages will adjust automatically to the ambient noise level up to a maximum of 100 dBA. Provide the custom speech messages in both English and Spanish languages. Ensure you can program the accessible pedestrian signal by a means not readily accessible by unauthorized persons.

Ensure each pushbutton provides a standard locator tone that is deactivated when the traffic signal is operating in the flash mode. Provide a user-programmable audible beaconing feature that is initiated by an extended push button press of one second or more. Ensure the audible beaconing feature increases the volume of the pushbutton locator tone during the pedestrian change interval of the called pedestrian phase and operates in one of the following ways:

- A. The louder audible walk indication and louder locator tone comes from the far end of the crosswalk, as pedestrians cross the street,
- B. The louder locator tone comes from both ends of the crosswalk, or
- C. The louder locator tone comes from an additional speaker that is aimed at the center of the crosswalk and that is mounted on a pedestrian signal head.

Provide confirmation of the pushbutton activation by an LED pilot light. Ensure the pilot light remains illuminated until the pedestrian's green or WALKING PERSON (symbolizing WALK) signal indication is displayed. Ensure each press of the pushbutton initiates a "wait" speech message during all intervals except the Walk interval.

◆ **Revision No. 1, April 10, 2017 – This document supersedes version originally issued and sealed by J. Todd Brooks, NCPE No. 017586 on 12/28/2016.**

U-4715B

ITS-81

Buncombe County

Ensure you can select a percussive tone and custom speech message to sound during the “Walk” interval. Provide a pushbutton that vibrates during the “Walk” interval. Ensure the “Walk” indications have the same duration as the illuminated pedestrian signals except when the signal is programmed to rest in the walk interval. Ensure the “Walk” indications are deactivated when the traffic control signal is operating in a flashing mode. When audible “Walk” indications are selected as a percussive tone, ensure the tone repeats at 8 to 10 ticks per second and consists of multiple frequencies with a dominant component at 880 Hz.

Ensure the accessible pedestrian signals are weatherproof and suitable for operation in wet locations. Ensure proper operation over a temperature range of -30°F (-34°C) to 165°F (+74°C). Ensure all circuit boards have a moisture resistant coating. Ensure the equipment interfaces and operates properly in a Type-170E cabinet.

5.3. CONSTRUCTION METHODS

Construct the integrated pushbutton accessible pedestrian signals (APS) as shown in the Plans as soon as possible upon receipt of notice to proceed.

Comply with the requirements of Section 1705 of the *Standard Specifications*. Install in accordance with the manufacturer’s recommendations.

Mount push button integrated accessible pedestrian signals in a tamperproof manner on wood and metal poles, signal pedestals, or pushbutton posts as indicated in the signal plans.

Install each pushbutton so that the tactile arrow is pointed in the direction of travel and is aligned parallel to the direction of travel on the associated crosswalk.

Ensure pushbuttons are separated by a distance of at least 10 feet such that they clearly indicate which crosswalk has the WALK indication. Where there are constraints on a particular corner that make it impractical to provide the 10 feet of separation between the two pushbuttons, the pushbuttons may be placed closer together or on the same pole, with approval by the Engineer. If two pushbuttons are placed on the same pole or with less than 10 feet separation, provide a speech walk message for the WALK indication and a speech pushbutton information message.

Adjust the intensity of the pushbutton locator tones so they are audible 6 feet to 12 feet from the pushbutton, or to the building line, whichever is less. Ensure the pushbutton locator tones are no more than 5 dBA louder than ambient sound. Configure audible “Walk” indication to be audible at the nearest end of the associated crosswalk.

If speech messages are used, have each recorded custom speech message approved by the Engineer in advance.

5.4. MEASUREMENT AND PAYMENT

APS detector stations will be measured and paid as the actual number of pushbutton integrated accessible pedestrian signal detector stations furnished, installed, and accepted.

Central control unit for APS detector stations will be measured and paid as the actual number of central control units for APS detector stations furnished, installed, and accepted.

No measurement will be made of cables or hardware, as these will be considered incidental to furnishing and installing pushbutton integrated accessible pedestrian signals.

◆ **Revision No. 1, April 10, 2017 – This document supersedes version originally issued and sealed by J. Todd Brooks, NCPE No. 017586 on 12/28/2016.**

U-4715B

ITS-82

Buncombe County

Payment will be made under:

Pay Item

Pay Unit

APS Detector Stations

Each

Central Control Unit for APS Detector Stations

Each

6. MESSENGER CABLE

6.1. DESCRIPTION

Furnish and install messenger cable (span wire) with cable clamps, machine bolts, eyebolts, 3-bolt clamps, J-hooks, eye nuts, split-bolt connectors, metal pole clamps, stainless steel bands, and all necessary hardware.

Furnish and install pole grounding systems consisting of #6 AWG solid bare copper wire, messenger bonding clamps, hot-dipped galvanized wire staples, ground rods, and exothermic welding.

6.2. MATERIALS

A. General

Material, equipment, and hardware furnished under this section shall be pre-approved on the ITS & Signals QPL.

B. Messenger Cable

Comply with ASTM A475 for extra high strength grade wire strand, Class A zinc coating. Fabricate messenger cable from seven steel wires twisted into a single concentric strand.

C. Pole Line Hardware

Provide universal grade strandvises used for extra high strength steel messenger cable.

Provide other pole line hardware constructed of hot-dipped galvanized steel conforming to ASTM A153.

Provide machine bolts, eyebolts, and thimble eye bolts with minimum tensile strength of 12,400 lbs. Provide hot-dipped galvanized nuts, 3" x 3" curved square washers, and thimbleyelets.

Provide suspension clamp fabricated from hot-dipped galvanized steel with minimum length of 5 3/4". Ensure clamp has a groove rated for the messenger cable size it is intended to secure. Provide J-hook fabricated from 3/8" thick hot-dipped galvanized steel flat or oval stock with sufficient hook radius to cradle 11/16" diameter cable. Provide two 1/2" diameter hot-dipped galvanized bolts and nuts to tighten the clamp around the messenger cable. Provide one 5/8" diameter hot-dipped galvanized bolt of sufficient length to attach J-hook and clamp to the wood pole with a 3" x 3" curved square washer and double nuts.

Provide 3-bolt clamp fabricated from hot-dipped galvanized steel with minimum length of 5-3/4". Ensure clamp has 2 parallel grooves rated for the messenger cable size it is intended to secure. Provide three 5/8" diameter hot-dipped galvanized bolts and nuts to tighten the clamp around the messenger cable.

Provide parallel groove clamp consisting of high strength, high conductivity non-copper bearing aluminum alloy clamp halves with interlocking fingers to prevent mismatch. Ensure clamp halves have molded grooves to secure #8-1/0 AWG stranded copper wires. Provide clamps with grooves prefilled with antioxidant joint compound. Provide 3/8" hex head, square shank, galvanized steel bolt with galvanized steel lock washer and nut.

◆ **Revision No. 1, April 10, 2017 – This document supersedes version originally issued and sealed by J. Todd Brooks, NCPE No. 017586 on 12/28/2016.**

Provide 1/2" and 3/4" wide, .030" thick Type 316 stainless steel straps with Type 316 stainless steel buckles.

Provide either 0.05" x 0.30" aluminum wrapping tape or 0.06" diameter Type 316 stainless steel lashing wire for lashing cables to messenger cable. Ensure aluminum wrapping tape is 1350 alloy, O-temper, with 12,800 psi tensile strength. Use 0.045" diameter Type 316 stainless steel lashing wire to lash fiber-optic communications cable to messenger cable.

Provide hot-dipped galvanized steel clamp with groove sized for 1/4" to 3/8" messenger cable for securing lashing wire(s) to messenger cables at ends of each spiraled run. Ensure clamp hardware is hot-dipped galvanized steel.

Provide galvanized metal pole clamps and stainless steel banding hardware for attaching pole line hardware (e.g., strandvises, three-bolt clamps, etc.) to metal signal poles.

Refer to the following article 1091-2, "Wire", of the *Standard Specifications*.

D. Grounding Electrodes

Provide grounding electrodes (i.e., ground rods) as indicated in these Project Special Provisions and on the Plans. Provide 5/8" diameter, 10-foot long, copper-clad steel ground rods with 10 mil thick copper cladding.

6.3. CONSTRUCTION METHODS

A. General

Install guy assemblies before installing messenger cable.

Use 3/8-inch messenger cable for spans supporting vehicle signal heads, and/or signs.

Use 1/4-inch messenger cable for spans supporting only cables unless otherwise specified.

For messenger cable crossing over railroad tracks, provide a minimum of 27 feet of vertical clearance, unless otherwise specified.

For permanent installations, install messenger cable in continuous lengths with no splices except where an insulator is required. With prior approval, existing messenger for temporary installations may be extended instead of installing new messenger cable.

Tension messenger cable to eliminate appreciable sag and to match sag of surrounding utilities. Otherwise, allow 3% to 4% sag of the span length between poles.

For mid-run spans using wood poles, attach messenger cable to the pole with a 3-bolt cable clamp with J-hook consisting of 5/8" diameter machine bolts, J-hooks, washers and square nuts to attach messenger cable to wood poles. Provide machine bolts that are 3" longer than the pole diameter. For mid-run spans using metal or other Department-approved poles, attach messenger cable to the pole with a 3-bolt clamp with J-hook secured to the metal pole via a pole band clamp. Refer to *Metal Pole Standard Drawing Sheet M6* found on the Department's website.

When terminating spans at wood poles, connect messenger cable to a dead-end strandvise attached to the pole via a 5/8" diameter shoulder eye bolt or 5/8" diameter shoulder angle bolt with 5/8" eye nut as shown in *Roadway Standard Drawing No. 1720.01*. When terminating spans at metal or other Department-approved poles, connect messenger cable to a dead-end strandvise attached to the pole via a pole attachment clamp. Refer to *Metal Pole Standard Drawing Sheet*

◆ **Revision No. 1, April 10, 2017 – This document supersedes version originally issued and sealed by J. Todd Brooks, NCPE No. 017586 on 12/28/2016.**

U-4715B**ITS-85****Buncombe County**

M6 as shown in the previous paragraph. Do not install more than one messenger cable and strandwise assembly to a single metal or other Department-approved pole attachment clamp. During installation, ensure that messenger cable is centered and directly aligned at the pole clamp's attachment point such that the cable does not exert forces on the sides of the clamp's attachment point.

Do not drill holes in metal poles to attach messenger cable. Do not attach messenger cable to metal poles that are owned by anyone other than the City or the Department without prior approval of the Engineer and the pole owner. Where such attachments are approved, use attachment methods and hardware approved by the pole owner.

Maintain electrical continuity at all splices.

On joint use poles at signal and ITS equipment installations (i.e., Controller Cabinets, CCTV Cabinets, etc.), do not use existing utility company grounds. Install a new, separate grounding system for the signal and ITS equipment.

B. Messenger Cable for Signal Heads or Loop Lead-In Cable

For messenger cable attached to joint use poles, install a new pole grounding system that complies these Project Special Provisions. If a pole ground exists on a joint use pole, bond new pole grounding system to existing pole ground using number 6 AWG minimum solid bare copper grounding wire terminated with split bolt connectors or parallel groove clamps at each end. If existing poles do not have a pole grounding system, install a new pole grounding system that complies with the requirement of the "Wood Poles" section of the *Standard Specifications*, except use hot-dipped galvanized 1.5" wire staples to secure ground wire to pole, spacing the staples along the pole as follows:

- 4 inches apart from ground level to 8 feet above ground level;
- 24 inches apart from 8 feet above ground level to point adjacent to uppermost span.

C. Messenger Cable for Communications Cable

For messenger cable attached to joint use poles, bond messenger cable to existing pole ground at each end and at 1300-foot intervals. Install bond using #6 AWG minimum solid bare copper grounding wire terminated with split bolt connectors or parallel groove clamp at each end. If existing poles do not have a pole grounding system, install a new pole grounding system that complies with the requirement of the "Wood Poles" section of the *Standard Specifications*, except use hot-dipped galvanized 1.5" wire staples to secure ground wire to pole, spacing the staples along the pole as follows:

- 4 inches apart from ground level to 8 feet above ground level;
- 24 inches apart from 8 feet above ground level to point adjacent to uppermost span.

D. Messenger Cable for Multiple Cables

On multiple messenger cable arrangements, connect all messenger cable ends with #6 AWG minimum solid bare copper wire and bond with split bolt connectors or parallel groove clamp and terminate to pole ground.

◆ **Revision No. 1, April 10, 2017 – This document supersedes version originally issued and sealed by J. Todd Brooks, NCPE No. 017586 on 12/28/2016.**

U-4715B

ITS-86

Buncombe County

6.4. MEASUREMENT AND PAYMENT

Messenger cable (_____) will be measured and paid for as actual horizontal linear feet of messenger cable furnished, installed, and accepted. Measurement will be point to point with no allowance for sag.

No measurement will be made of cable clamps, machine bolts, eye bolts, 3-bolt assemblies, J-hooks, eye nuts, split bolt connectors, metal pole clamps, and stainless steel banding hardware as these will be considered incidental to furnishing and installing messenger cable. Bonding to an existing pole grounding system will be considered incidental to furnishing and installing messenger cable.

Ground rods installed as part of pole grounding systems will be measured and paid for in accordance with the "Electrical Service" section of these Project Special Provisions. No measurement will be made for furnishing and installing #6 AWG solid bare copper wire, messenger bonding clamps, hot-dipped galvanized wire staples, and exothermic welding as part of pole grounding systems as such work will be considered incidental to furnishing and installing the wood poles, messenger cable and grounding electrodes.

Payment will be made under:

| Pay Item | Pay Unit |
|------------------------|-----------------|
| Messenger Cable (1/4") | Linear Foot |
| Messenger Cable (3/8") | Linear Foot |

◆ **Revision No. 1, April 10, 2017 – This document supersedes version originally issued and sealed by J. Todd Brooks, NCPE No. 017586 on 12/28/2016.**

7. UNDERGROUND CONDUIT

7.1. DESCRIPTION

Furnish and install conduit for underground installation with tracer wire, miscellaneous fittings, all necessary hardware, marker tape, backfill, graded stone, paving materials, and seeding and mulching.

7.2. MATERIALS

A. General

Except for HDPE conduit, furnish material, equipment, and hardware under this section that is pre-approved on the ITS and Signals QPL.

Refer to the following articles of the *Standard Specifications*:

Backfill 1018-2

Graded Stone 545-2 and 545-3

B. Conduit Bodies, Boxes and Fittings

Use conduit bodies, boxes, and fittings that meet UL Standard 514A or 514B for electrical and communications installations.

C. Conduit Types

(1) Rigid Metallic Conduit

Provide rigid hot dipped galvanized steel conduit that meets UL Standard 6 with rigid full weight sherardized or galvanized threaded fittings.

(2) PVC Conduit

Provide non-metallic conduit and duct including associated couplings, approved for below ground use with or without concrete encasement in accordance with UL Standard 651A. Provide Schedule 40 conduit unless otherwise specified.

(3) Solid Wall HDPE Conduit

Use HDPE conduit that conforms to UL Standard 651B. Provide conduit meeting the requirements of the table below with minimum wall thickness ratios corresponding to EPEC-40 (Schedule 40), EPEC-80 (Schedule 80) or EPEC-B (SDR 13.5) as listed in UL Standard 651B, Table 5.1, 5.2 and 5.3.

Provide HDPE conduit with an outer diameter to minimum wall thickness ratio that complies with ASTM D 3035, Standard Dimension Ratio (SDR) 13.5.

U-4715B

ITS-88

Buncombe County

| HDPE CONDUIT SIZE | |
|--------------------|-------------------|
| Conduit Trade Size | Furnish |
| 1" | EPEC-40 |
| 1-1/4" | EPEC-40 |
| 1-1/2" | EPEC-B (SDR 13.5) |
| 2" | EPEC-B (SDR 13.5) |
| 2-1/2" | EPEC-B (SDR 13.5) |
| 3" | EPEC-B (SDR 13.5) |
| 4" | EPEC-B (SDR 13.5) |
| 5" | EPEC-80 |
| 6" | EPEC-80 |

Ensure the PE resin compounds used in manufacturing the conduit meet or exceed the cell classification PE 334420C (black with 2% minimum carbon black) or PE 334420E (colored conduit with UV inhibitors) in ASTM D3350 and the table below.

| RESIN PROPERTIES | | |
|--|--|---------------------------------------|
| Property | Requirement | Test Method |
| Density | 0.940 - 0.947g/cm ³ | ASTM D1505 ASTM D792 ASTM D4883 |
| Melt Index (condition 190/2.16 is acceptable) | < 0.4 grams/10 minutes | ASTM D1238 |
| Flexural Modulus | 80,000 psi, min. | ASTM D790 |
| Tensile Strength | Tensile Strength 3,000 psi, min. | ASTM D638 |
| Elongation | Elongation 400%, min. | ASTM D638 |
| Slow Crack Growth Resistance | An ESCR as per condition B, 10% IGEPAL requirement of F50>24 hrs is allowable | ASTM D1693 |
| Hydrostatic Design Basis | "0" for Non-Pressure Rated Pipe | ASTM D2837 |
| UV Resistance (Outdoor Conduit Only) | Stabilize with at least 2% by weight carbon black or colored with UV Inhibitor | ASTM D4218 |

◆ **Revision No. 1, April 10, 2017 – This document supersedes version originally issued and sealed by J. Todd Brooks, NCPE No. 017586 on 12/28/2016.**

U-4715B

ITS-89**Buncombe County**

Furnish conduits in the colors for the applications shown in the table below. For conduits manufactured with stripes, ensure the stripes are uniformly located around the conduit with 120 degrees of separation. Do not use “Solid Yellow” or “Black with Yellow Stripes” conduit.

| CONDUIT COLORS | | |
|--|------------------------------|---------------------------|
| Conduit Contents | Preferred Solid Color | Alternate |
| Signal Cable | Black | None |
| Loop Lead-in Cable | White | Black with White Stripes |
| Communications Cable (Copper, Fiber-Optic, Coaxial) | Orange | Black with Orange Stripes |
| Electrical Power Cable | Red | Black with Red Stripes |

Ensure the HDPE conduit is resistant to benzene, calcium 1 chloride, ethyl alcohol, fuel oil, gasoline, lubricating oil, potassium chloride, sodium chloride, sodium nitrate and transformer oil and is protected against degradation due to oxidation and general corrosion.

Furnish factory lubricated, low friction, conduit with a coefficient of friction of 0.10 or less in accordance with Telcordia GR-356. Ensure the supplied conduit is identified and certified as meeting, UL Standard 651B. Ensure the conduit is marked at least with the following information on 10 ft or less intervals:

- 1) Material: HDPE
- 2) Trade Size: i.e., 2"
- 3) Conduit Type: SDR 13.5 or EPEC-B
- 4) Manufacturer's name or trademark
- 5) Manufacturer's identity code to identify manufacturing date, facility, etc.
- 6) UL symbol or UL listing number

Furnish coilable conduit that is supplied on reels in continuous lengths for transportation and storage outside. Ensure that the process of installing the coilable conduit on the reel does not alter the properties or performance of the conduit for its intended purpose.

D. Conduit Plugs, Pull Line, and Tracer Wire

Furnish conduit plugs that provide a watertight barrier when installed in conduit. Furnish conduit plugs sized in accordance with conduit. Ensure conduit plug provides a means to secure a pull line to the end of the plug. Provide removable and reusable duct plugs. Conduit plugs are not required to be listed electrical devices.

For all spared conduits, furnish 3/4", pre-lubricated, woven polyester tape, pull line with minimum rated tensile strength of 2,500 lb. Pull lines are not required to be listed electrical devices.

◆ **Revision No. 1, April 10, 2017 – This document supersedes version originally issued and sealed by J. Todd Brooks, NCPE No. 017586 on 12/28/2016.**

U-4715B**ITS-90****Buncombe County**

Provide green insulated number 14 AWG, THWN, stranded copper wire to serve as tracer wire.

Furnish non-detectable underground marker tape with the wording “WARNING – Fiber-Optic Cable” in all trenches containing one or more conduits that will house fiber-optic communications cable.

E. Mechanical Couplings for HDPE Conduit

Provide mechanical couplings that are both watertight and airtight for joining two segments of HDPE conduit of like diameter. Provide couplings designed to accommodate pneumatic methods of cable installation. Provide couplings suitable for burial underground and which meet the following requirements:

- The coupling shall not fail by leakage when subjected to sustained internal pressure testing as noted in ASTM F 2176.
- The coupling shall not fail by leakage when subjected to sustained external pressure testing as noted in ASTM F 2176.
- The coupling assemblies tested shall be able to comply with the tensile loading requirements as specified in ASTM F 2176.
- As specified in ASTM F 2176, the coupling shall not fail when conditioned at low temperature conditions of 10° F and tested by an impact with a force of 20 ft-lb using Type “B” as described in Test Method ASTM D 2444.

F. Duct and Conduit Sealer

Use duct and conduit sealer or mastic which is a putty-like compound and:

- Is permanently non-hardening, non-oxidizing, and non-corrosive to metals, rubber, plastic, lacquer and paints;
- Is readily workable for thumbing into openings and forming into seals around wires inside conduits and openings around conduits;
- Has a service temperature range of minus 30°F to 200°F;
- Is clean, non-poisonous and non-injurious to human skin;
- Seals against water, dust and air and shall adhere to wood, glass, plastics, metal, rubber and painted surfaces; and
- Is non-conductive.

7.3. CONSTRUCTION METHODS

A. General

Except where the Plans call for a specific installation method or where the Engineer directs otherwise, underground conduit may be installed by either trenching, directional drilling or plowing at the option of the Contractor but will be measured and paid for as “underground conduit,” regardless of installation method (see “Measurement and Payment” subsection).

Refer to Section 1 of these Project Special Provisions for additional requirements concerning work within and adjacent to historic districts.

Ensure conduit is free of moisture and debris before pulling cables.

◆ **Revision No. 1, April 10, 2017 – This document supersedes version originally issued and sealed by J. Todd Brooks, NCPE No. 017586 on 12/28/2016.**

Where cable is not immediately installed or conduit is for future use (spare), seal the ends of the conduit with a conduit plug immediately following installation of the conduit. Secure a pull line to the conduit plug in such a manner that it will not interfere with installation of the conduit plug and provides a watertight seal.

Extend ends of conduit 2” to 4” above concrete surfaces and 4” above crushed stone bases. For metallic conduit, install metallic bushings and bond conduits.

All conduits installed in a common trench or bore must be the same size and all conduits in a continuous longitudinal run must be the same size. Do not intermix different size conduits in the same run.

Install a minimum of two conduits (i.e., at least one for fiber-optic cable plus one dedicated spare) for all underground routes unless the Plans show otherwise. Exceptions on plans may include short runs to CCTV cameras, short PVC runs to controller cabinets from main trunk line, or installations under railroad tracks.

Install junction boxes in underground conduit runs as shown on the Plans. Do not exceed 150 feet between junction boxes in any underground conduit route that conveys traffic signal or lead-in cable and 1,000 feet between junction boxes in any underground conduit route that conveys communications cable without the prior approval the Engineer.

Comply with the “Blue Ridge Parkway Vegetation Management Guidelines for Right-of-Ways” when installing underground conduits and junction boxes in the vicinity of the Blue Ridge Parkway along US 74A (Charlotte Highway) and NC 191 (Brevard Road).

1. Conduit Entering Junction Boxes

Terminate conduits installed for communications cables (fiber-optics, Ethernet and coaxial) in oversized or special-sized junction boxes as shown on the Plans. Do not install other conduits in these junction boxes unless otherwise specified.

Terminate conduits installed for signal wiring, including loop lead-in cable, in standard size junction boxes unless otherwise specified.

For all conduits entering junction boxes, seal spare conduits with approved conduit plugs. Seal conduits containing fiber-optic communications cable, Ethernet cable, signal cable and lead-in cable with duct and conduit sealer.

2. Tracer Wire

Install tracer wire in all conduits containing fiber-optic cable, unless otherwise indicated on the Plans or the Engineer directs otherwise. Pull tracer wire simultaneously in continuous length with the fiber-optic cable. Where multiple pulls of fiber-optic cable are required and conduit is placed in the same trench, only one tracer wire is required. Where multiple pulls of fiber-optic cable are required and conduits may separate into individual trenches, install a tracer wire in each conduit run. Splice tracer wire only in cabinets and junction boxes using waterproof butt splice connectors. Coil and store 10 feet of spare tracer wire in junction boxes. Label all tracer wires entering an equipment cabinet. For a given tracer wire run between two controller cabinets, bond the tracer wire to the equipment ground inside the controller cabinet at one end of run only; do not bond both ends of the tracer wire in a continuous run to cabinet grounds at each end of the run. Establish a consistent convention for which end the tracer wire will be bonded along a give

U-4715B

ITS-92

Buncombe County

roadway or corridor. For example, bond the end of the tracer wire closest/to (in the direction of) the downtown Asheville.

3. Ground Surface Restoration

Upon completion of conduit installation and backfilling of all trenches and other excavations, restore the disturbed ground to its original condition as determined and approved by the Engineer. For paved areas, replace removed or damaged pavement with in kind materials, matching the elevation, color, texture/finish and general appearance of the surrounding pavement. Refer to Section 1 of these Project Special Provisions for additional requirements concerning sidewalks and curbs in historic districts. For unpaved areas, backfill excavations with removed material, tamp the backfilled material and rake smooth the top 1½ inches. Finish unpaved areas flush with surrounding natural ground and to match the original contour of the ground. Seed with same type of grass as surrounding area and mulch the newly seeded area. If unpaved area was not grassed, replace the original ground cover in kind as directed by the Engineer.

Complete repairs to and restoration of all ground (paved and unpaved) disturbed by construction within five consecutive calendar days following initial removal. If the Contractor fails to repair and restore the ground in accordance with these Project Special Provisions within the time frame specified, the Department reserves the right to make the necessary repairs, and all expenses incurred by the Department in making the repairs and restoring the ground will be deducted from payment due the Contractor, plus **\$500 liquidated damages per occasion, per day, or any portion** thereof, until corrected.

4. Plan of Record Drawings

Upon completion of the conduit system for communications, furnish the Engineer with a plan of record drawing detailing both the horizontal and vertical (i.e. depth) locations of the conduit system.

B. Trenching

1. General

Install PVC, HDPE, or rigid metallic conduit for all underground runs as specified in the Plans. Install rigid metallic conduit for all trenched underground runs located inside railroad right-of-way, unless otherwise specified. Clean existing underground conduit to be incorporated into a new system by drawing a mandrel through the conduit followed by a swab. Clear obstructions or blockages in an existing underground conduit designated for reuse by using compressed air, water jetting, rod and mandrel or other method as approved by the Engineer. Once obstruction/blockage has been cleared, perform aforementioned cleaning procedure to clean out any remaining materials which may cause cable abrasions. Bond all metallic conduit.

If more than one conduit is required between the same points, install conduit in one common trench.

Install non-detectable marker tape longitudinally in the trench 6 to 12 inches below the unpaved ground surface or below the underside of the paved surface.

Install longitudinal runs of conduit a minimum of 1 foot from back of curb or 6 feet from edge of pavement in the absence of curb. If ditches are present, install conduit a minimum of 4 feet from the bottom of the ditch line.

◆ **Revision No. 1, April 10, 2017 – This document supersedes version originally issued and sealed by J. Todd Brooks, NCPE No. 017586 on 12/28/2016.**

U-4715B

ITS-93

Buncombe County

Maintain a minimum trench depth of 30" (or 12" in areas blocked by rock or impenetrable obstructions) below finished grade or 6" below roadway sub-base, whichever is deeper. Upon completion, restore surface to like-original condition within five consecutive calendar days of occurrence of damage. Remove all rock and debris from backfill material. Remove excess material from site and compact area according to Article 300-7 of the *Standard Specifications*. Backfill with excavated material and compact to 95% of original density.

Backfill trench at locations along the trench path where non-movable objects, such as rocks and boulders, cannot be avoided. The purpose of the backfill is to provide a gradual change in elevation of the trench, so that excessive bending and stress will not be transferred to conduits once underground conduit system is installed.

After installation of conduits and upon completion of tamping and backfilling, perform a mandrel test on each conduit to ensure no conduit has been damaged. Furnish a non-metallic mandrel having a diameter of approximately 50% of the inside diameter of the conduit in which it is to be pulled through. If damage has occurred, replace the entire length of conduit. Ensure pull line is re-installed.

Use HDPE conduit in trenched areas unless otherwise specified in the Plans. Use 2-inch PVC or rigid galvanized conduit between junction boxes adjacent to the controller cabinet and the 2-inch conduit stub-outs from the cabinet foundation.

Comply with the *NCDOT Policies and Procedures for Accommodating Utilities on Highway Rights-of-Way* in effect on the date of advertisement.

2. Unpaved Trenching

Install conduit in unpaved areas. Rake smooth the top 1-1/2 inches and seed with same type of grass as surrounding area. Finish unpaved areas flush with the surrounding natural ground. Restore damaged grassed areas. Seed and mulch, using methods and material approved by the Engineer, within five consecutive calendar days following initial damage to grassed areas, unless the Engineer approves otherwise due to weather and soil conditions. If the Contractor fails to repair the grassed areas in accordance with these Project Special Provisions within the time frame specified, the Department reserves the right to make the necessary repairs, and all expenses incurred by the Department in making the repairs and restoring the grassed area will be deducted from payment due the Contractor, plus **\$500 liquidated damages per occasion, per day, or any portion thereof**, until corrected.

Adapt operations to variations in weather or soil conditions as necessary for the successful establishment and growth of the grasses. When the Engineer determines that weather and soil conditions are unfavorable, including but not limited to extremely wet or frozen soil, do not distribute any limestone or fertilizer and do not sow any seed. During seasons of the year when temperatures are not conducive to germination and growth of the type of grass seed to be planted, seed and mulch the disturbed areas with temporary seeding that will germinate and grow under the prevailing temperatures until such time that permanent seeding can be established, as approved and directed by the Engineer.

As directed by the Engineer, apply additional seed or completely reseed areas which have been previously seeded and mulched but which have been damaged, have failed to successfully establish a stand of vegetation or have an unsatisfactory cover of vegetation. Perform supplemental and repair seeding promptly at all locations and times as directed by the Engineer.

◆ **Revision No. 1, April 10, 2017 – This document supersedes version originally issued and sealed by J. Todd Brooks, NCPE No. 017586 on 12/28/2016.**

U-4715B

ITS-94

Buncombe County

3. Paved Trenching

On concrete surfaces, replace the entire joint of concrete and match the original concrete as to color and finish unless otherwise specified. On all other surfaces, neatly cut and replace the width of trench with like material. Refer to Section 1 of these Project Special Provisions for additional requirements concerning sidewalks and curbs in historic districts. Place graded stone material to temporarily maintain pedestrian traffic where repairs cannot be performed immediately.

Finish paved areas with materials matching damaged areas. For conduit installed under roadways, cut neatly and replace the width of paved area damaged by trenching. For conduit installed under sidewalks and walkways, remove entire section of slab from joint to joint and replace. Place graded stone material to temporarily maintain traffic where repairs cannot be performed immediately. Comply with Article 545-4 of the *Standard Specifications*.

Complete repairs to all paved areas removed for construction within five consecutive calendar days following initial removal. If the Contractor fails to repair the paved area in accordance with these Project Special Provisions within the time frame specified, the Department reserves the right to make the necessary repairs, and all expenses incurred by the Department in making the repairs and restoring the paved area will be deducted from payment due the Contractor, plus **\$500 liquidated damages per occasion, per day, or any portion thereof**, until corrected.

C. Plowing (HDPE Conduit Only)

Direct plow HDPE ducts simultaneously using chute plow method. Direct plow ducts at a minimum depth so the top of the highest duct is 30 inches deep unless otherwise approved.

Provide sufficient personnel to feed chute, operate prime mover and equipment carrying reels (if separate equipment is used), observe chute feeding, observe plowing, and observe reel payout. Use chute with adequate dimensions to allow for passage of duct without damage. During plow operation, continuously check chute opening and path to be sure there are no obstructions and monitor payout reels to be sure reels are turning at a steady rate.

D. Directional Drilling

1. Pre-Approvals and Minimum Depth Requirements

Obtain approval before beginning drilling operations.

At all points where HDPE conduit will traverse under roadways, driveways, sidewalks, or Controlled Access Areas including entrance/exit ramps, maintain a minimum depth of 4 feet or 8 times the back reamer's diameter, whichever is deeper. For an installation that runs parallel to a controlled access area or entrance/exit ramps maintain a minimum depth of 30 inches below finished grade. Maintain a minimum clearance of 30 inches below finished grade when crossing ditch lines.

◆ **Revision No. 1, April 10, 2017 – This document supersedes version originally issued and sealed by J. Todd Brooks, NCPE No. 017586 on 12/28/2016.**

U-4715B

ITS-95

Buncombe County

For the following structures, the minimum clearance requirements are:

| MINIMUM CLEARANCE REQUIREMENTS FOR STRUCTURES | |
|--|---|
| Man-made Structure | Minimum Clearance Requirement |
| Bridge foundation | 5' horizontal & 4' vertical (clearances greater than minimum horizontal should continue to use the 4V:5H ratio, i.e., 10' horizontal should be no deeper than 8') |
| Drainage pipes 60" or less | 1' above or below [while maintaining a minimum depth of 30" below grade] |
| Drainage pipes greater than 60" | 1' above or 4' below [while maintaining a minimum depth of 30" below grade] |
| Box Culverts | 1' above or 4' below [while maintaining a minimum depth of 30" below grade] |
| Slope protection | 2' below |
| Slope protection foundation footing | 5' below |

At points where HDPE conduit will traverse under the East Fork Deep River, maintain a minimum depth of 10 feet from top of conduit to bottom of river bed at all points along the bore. In addition, maintain a depth of at least 10 feet below the surface of the river banks.

Guarantee the drill rig operator and digital walkover locating system operator are factory-trained to operate the make and model of equipment provided and have a minimum of one-year experience operating the make and model of drill rig. Submit documentation of the operators' training and experience for review at least two weeks before start of directional drilling operations.

Provide a means of collecting and containing drilling fluid/slurry that returns to the surface such as a slurry pit. Provide measures to prevent drilling fluids from entering drainage ditches, storm sewer systems or bodies of water (streams, rivers, ponds and lakes). Prevent drilling fluid/slurry from accumulating on or flowing onto pedestrian walkways, driveways, and streets. Disposal on public or railroad right-of-way or railroad drainage ditches/facilities is prohibited. Immediately remove all drilling fluids/slurry that are accidentally spilled.

Provide all drilling equipment, tooling, personnel and techniques necessary to complete the installation of the underground conduit through directional drilling for all soil conditions encountered, all drilling depths specified and all drilling lengths specified in these Project Special Provisions and as shown in the Plans.

2. Directional Drill Operations

Provide grounding for the drill rig in accordance with the manufacturer's recommendations. Place excavated material near the top of the working pit and dispose of properly. Backfill pits and trenches to facilitate drilling operations immediately after drilling is completed.

No geotechnical investigations have been performed at the sites of proposed directional drill operations for this project. Prior to performing the directional drilling operation, field investigate the site of the proposed directional drill conduit, including but not limited to walking the bore

◆ **Revision No. 1, April 10, 2017 – This document supersedes version originally issued and sealed by J. Todd Brooks, NCPE No. 017586 on 12/28/2016.**

U-4715B**ITS-96****Buncombe County**

path and talking to adjacent property owners, to ascertain the soil conditions that may be encountered and to review the site's topography. Ensure that the equipment, tooling, personnel expertise and techniques used at each site are sufficient to complete the directional drill operation successfully, regardless of soil conditions encountered. At all times, have alternate drill heads available in case the soil conditions do not match expected conditions.

Use drill head suitable for type of material being drilled and sized no more than 2 inches larger than the outer diameter of the conduit. Pressure grout with an approved bentonite/polymer slurry mixture to fill all voids. Do not jet alone or wet bore with water.

During drilling operation, locate drill head every 10 feet along drill path and before traversing underground utilities or structures. Use digital walkover locating system to track drill head during directional drilling operation. Ensure locating system is capable of determining pitch, roll, heading, depth, and horizontal position of the drill head at any point.

Once drill head has reached final location, remove head, and install back reamer of appropriate size (no more than 2 inches larger than outer diameter of conduits to simultaneously facilitate back reaming of drill hole and installation of conduit. Use back reamer that is sized larger than actual conduits to ensure conduits are not adversely subjected to deviations caused by the original drill operation and are as straight as practical in their final position.

The intent of these Project Special Provisions is to limit the diameter of the actual drill shaft/hole so that it is no more than 2 inches larger than the conduit outer diameter.

Once installation of conduit has started, continue installation without interruption so as to prevent conduit from becoming firmly set. Apply bentonite/polymer slurry mixture during conduit installation.

Upon completion of conduit installation, perform a mandrel test on conduit system to ensure conduit has not been damaged. Furnish non-metallic mandrel with a diameter of approximately 50% of the inside diameter of the conduit in which it is to be pulled through. If damage has occurred, replace the entire length of conduit and ensure that pull line is re-installed.

3. Drilling Fluids

Use lubrication for subsequent removal of material and immediate installation of the conduit. The use of water and other fluids in connection with directional drilling operations will be permitted only to the extent necessary to lubricate cuttings. Do not jet alone or wet bore with water. Use drilling fluid/slurry consisting of at least 10% high-grade bentonite/polymer slurry to consolidate excavated material and seal drill hole walls.

Transport waste drilling fluid/slurry from site and dispose of in a method that complies with local, state and federal laws and regulations. Disposal on public or railroad right-of-ways or within public or railroad drainage ditches/facilities is prohibited. Disposal in streams, rivers, ponds, lakes and wetlands is also prohibited.

E. Maximum Length of Directional Drill

The length of a directional drill shall not exceed 1,000 feet measured horizontally along the route of the directionally drilled conduit(s), unless otherwise approved by the Engineer. For routes longer than 1,000 feet, begin a successive directional drill where the first directional drill reaches 1,000 feet and install an oversized heavy-duty junction box where the two directional

◆ **Revision No. 1, April 10, 2017 – This document supersedes version originally issued and sealed by J. Todd Brooks, NCPE No. 017586 on 12/28/2016.**

U-4715B

ITS-97

Buncombe County

drilled conduit runs meet. The spacing of junction boxes in a directionally drilled route shall not exceed 1,000 feet.

F. Splicing and Coupling of HDPE Conduit

Install a continuous HDPE conduit free from splices or couplings between junction boxes whenever possible. However, splicing or coupling of HDPE conduit may be permitted, subject to the prior approval of the Engineer, to complete an underground HDPE conduit run when the end of an HDPE reel is reached. However, splicing in the middle of a directional drill operation is prohibited.

Join the HDPE conduit ends by installing mechanical couplings in accordance with the manufacturer's instructions or by splicing the conduits using either a butt-fusion welder or an electro-fusion welder. Submit the proposed method of coupling or splicing the conduits to the Engineer for review and approval prior to joining any HDPE conduits.

Otherwise, install an oversized junction box where the ends of the HDPE conduits meet in lieu of joining the ends through splicing and coupling. Install an oversized junction box where the number of conduits in the underground run changes and where a directionally drilled conduit meets a trenched conduit. For example, install an oversized junction box where two directionally drilled conduits meet a single run of trenched conduit.

7.4. MEASUREMENT AND PAYMENT

Tracer wire will be measured along the horizontal linear feet of tracer wire furnished, installed, and accepted. Measurement will be along the approximate centerline of the conduit system. Payment will be made in linear feet. No payment will be made for excess tracer wire in junction boxes and/or cabinets.

Underground conduit (qty)(size) will be measured in horizontal linear feet of underground conduit installation of each type furnished, installed, and accepted, without regard to the installation method. Measurement will be along the approximate centerline of the conduit system. Payment will be in linear feet.

No measurement will be made of 1" underground conduit that conveys electrical service wire between a service riser and a disconnect/meter and between a disconnect and an equipment cabinet as such work will be considered incidental to furnishing and installing a new electrical service, furnishing and installing and CCTV cabinet disconnect or modifying an existing electrical service. (See "Electrical Service" section of these Project Special Provisions).

Directional drill (qty)(size) will be measured in horizontal linear feet of directional drill for underground conduit installation furnished, installed, and accepted. Measurement will be along the approximate centerline of the conduit system. Payment will be made in linear feet. When directional drilling is used where the Plans call for "Underground Conduit", directional drilling will be measured and paid for as Underground Conduit. There will be no additional compensation for field-investigating site conditions nor for providing any specialized equipment, tooling, personnel or techniques necessary to complete the installation of the underground conduit through directional drilling for the soil conditions encountered, including but not limited to rock, or for deep or long bores. There will be no additional requirements for any special measures required to protect bodies of water such as rivers, streams, ponds and lakes when drilling beneath as required by local, state and federal rules and regulations.

◆ **Revision No. 1, April 10, 2017 – This document supersedes version originally issued and sealed by J. Todd Brooks, NCPE No. 017586 on 12/28/2016.**

U-4715B**ITS-98****Buncombe County**

No measurement will be made of vertical segments, non-metallic conduit, metallic conduit, conduit sealing material, pull lines, duct plugs, marker tape, and miscellaneous fittings, as these will be considered incidental to conduit installation.

No measurement will be made of clearing existing blockages and obstructions from existing conduits nor for cleaning existing conduits prior to installation of new communications cable inside the existing conduits as such work will be considered incidental to furnishing and installing the communications cable.

No measurement will be made of restoration of paved roadways/driveways and unpaved ground surfaces with like materials, including but not limited to backfill, graded stone, paved materials, seeding and mulching, as this work will be considered incidental to conduit installation. No measurement will be made of removing, stockpiling and resetting existing granite curb as such work will be considered incidental to conduit installation. The Department will make no payment for a given underground conduit run until all repairs to paved and unpaved surfaces damaged/disturbed during the installation of the underground conduit have been completed and accepted.

Repair and replacement of existing sidewalk will be measured and paid for in accordance with the "Equipment Cabinet Foundations" section of these Project Special Provisions.

No measurement will be made of horizontal segments between the base of a riser and an adjacent junction box or base-mounted cabinet foundation that are 10 feet or less in length measured from the center of the riser to the center of the junction box or from the center of the riser to the center of the vertical sweep through the cabinet foundation as these will be considered incidental to riser installation.

No measurement will be made of conduit segments between adjacent traffic signal system junction boxes that are 10 feet or less in length measured from center of junction box to center of junction box as these will be considered incidental to furnishing and installing the junction boxes.

Conduit will be paid for per linear foot based on quantity and size of conduits. As examples, an installation of a single 2" HDPE conduit would be paid as:

Directional Drill (1)(2") Linear Foot

No measurement or payment will be made for furnishing and installing and subsequently removing graded stone material for temporary maintenance of traffic where a portion of existing pavement has been removed as such work will be considered incidental to furnishing and installing underground conduit.

Payment will be made under:

| Pay Item | Pay Unit |
|-----------------------------|-----------------|
| Tracer Wire | Linear Foot |
| Underground Conduit (1)(2") | Linear Foot |
| Underground Conduit (2)(2") | Linear Foot |
| Directional Drill (1)(2") | Linear Foot |
| Directional Drill (2)(2") | Linear Foot |

◆ **Revision No. 1, April 10, 2017 – This document supersedes version originally issued and sealed by J. Todd Brooks, NCPE No. 017586 on 12/28/2016.**

8. JUNCTION BOXES

8.1. DESCRIPTION

Furnish and install junction boxes (pull boxes) with covers, washed stone, grounding systems, and all necessary hardware.

8.2. MATERIALS

A. General

Provide electrical junction boxes with covers of the type and size indicated by the contract or the Plans for the termination of conduits, for splicing loop wires to loop lead-in cables and for splicing and storing fiber-optic communications cable.

Except for special-sized junction boxes, material, equipment, and hardware furnished under this section shall be pre-approved on the ITS and Signals QPL.

Provide #67 washed stone aggregates in conformance with Sections 545 and 1005 of the *Standard Specifications*.

B. Polymer Concrete (PC) Junction Boxes

Provide polymer concrete (PC) boxes which are stackable, have bolted covers and have open bottoms. Ensure vertical extensions of 6" to 12" are available from the junction box manufacturer.

Use polymer concrete material made of an aggregate consisting of sand and gravel bound together with a polymer and reinforced with glass strands to fabricate box and cover components which are exposed to sunlight. Other thermosetting glass-reinforced materials may be used for components which are not normally exposed to sunlight.

Provide certification that the polymer concrete boxes and covers meet Tier 15 requirements of ANSI/SCTE 77. Provide certification that testing methods are compliant with ANSI/SCTE 77.

Provide junction box covers with the required logos on the cover as follows (see NCDOT *Roadway Standard Drawing* No. 1716.01 for additional details):

- For standard size junction boxes ♦ that contain traffic signal cable and loop lead-in cable ♦, provide covers with the standard *TRAFFIC SIGNAL* logo;
- ♦ For standard size junction boxes that house electrical service conductors, provide covers with the standard *ELECTRIC* logo; and ♦
- For oversized and special-sized junction boxes, provide covers with the following standard logo/imprint: *NCDOT* (line 1) *FIBER* (line 2) *OPTIC* (line 3).

Provide at least 2 size 3/8" diameter hex head stainless steel cover bolts to match inserts in the box. Provide pull slot(s) with stainless steel pin(s). Polymer concrete junction boxes are not required to be listed electrical devices.

♦ **Revision No. 1, April 10, 2017 – This document supersedes version originally issued and sealed by J. Todd Brooks, NCPE No. 017586 on 12/28/2016.**

C. Junction Box Sizes

Provide junction boxes and covers of the following sizes as called for in the Plans:

| Junction Box Size | Minimum Inside Dimensions |
|-------------------|---------------------------|
| Standard Size | 16"(l) x 10"(w) x 10"(d) |
| Oversized | 30"(l) x 15"(w) x 24"(d) |
| Special-Sized | 36"(l) x 24"(w) x 24"(d) |

8.3. CONSTRUCTION METHODS

A. General

Install junction boxes flush with finished grade. Backfill beneath and around the junction box using #67 washed stone as shown in NCDOT *Roadway Standard Drawing* No. 1716.01. Do not install sealant compound between junction boxes and covers.

Upon completion of junction box installation and backfilling of all excavations, restore the disturbed ground to its original condition as determined and approved by the Engineer. For paved areas, replace removed or damaged pavement with in kind materials, matching the elevation, color, texture/finish and general appearance of the surrounding pavement. Refer to Section 1 of these Project Special Provisions for additional requirements concerning sidewalks and curbs in historic districts. For unpaved areas, backfill excavations with removed material, tamp the backfilled material and rake smooth the top 1½ inches. Finish unpaved areas flush with surrounding natural ground and to match the original contour of the ground. Seed with same type of grass as surrounding area and mulch the newly seeded area. If unpaved area was not grassed, replace the original ground cover in kind as directed by the Engineer.

Complete restoration of all ground disturbed during junction box installation within five consecutive calendar days following initial removal and excavation. If the Contractor fails to repair and restore the disturbed ground in accordance with these Project Special Provisions within the time frame specified, the Department reserves the right to make the necessary repairs, and all expenses incurred by the Department in making the repairs and restoring the ground will be deducted from payment due the Contractor, plus **\$500 liquidated damage per occasion, per day, or any portion thereof**, until corrected.

Install standard size junction boxes as shown in the Plans and where underground splicing of electrical cables is necessary. Install standard size junction boxes within 3 feet of pole or pole foundation where transitioning from below ground to a riser assembly. Install standard size junction boxes within 5 ft of each end of each lateral run of conduit for electrical cables. When lateral runs for electrical cables are greater than 150 feet, install additional junction boxes to ensure distances between junction boxes does not exceed 150 feet.

Install oversized junction boxes as shown in the Plans in underground fiber-optic communications cable runs where the conduit run transitions from directionally drilled conduit to trenched conduit and where transitioning from below ground to a riser assembly. Install

◆ **Revision No. 1, April 10, 2017 – This document supersedes version originally issued and sealed by J. Todd Brooks, NCPE No. 017586 on 12/28/2016.**

U-4715B

ITS-101

Buncombe County

oversized junction boxes in underground fiber-optic communications cable runs at maximum intervals of 1,000 feet, or where shown in the Plans, whichever is less.

Install special-sized junction boxes at all underground splice enclosure locations in underground fiber-optic communications cable runs as shown in the Plans.

B. GPS Coordinates

Provide real world coordinates for all junction boxes and equipment cabinets installed or utilized under this project. Provide the coordinates in feet units using the North Carolina State Plane coordinate system (1983 North American Datum also known as NAD '83). Furnish coordinates that do not deviate more than 1.7 feet in the horizontal plane and 3.3 feet in the vertical plane. Global positioning system (GPS) equipment able to obtain the coordinate data within these tolerances may be used. Submit cut sheets on the GPS unit proposed to collect the data for approval by the Engineer.

Provide both digital copies and hard copies of all information regarding the location (including to but not limited to manufacturer, model number, City system ID number and NCDOT inventory number) in the Microsoft Excel spreadsheet using the format shown in example below. In addition to Excel format, provide a digital copy of the location information as an ESRI Shapefile (.SHP file format).

| City Sys ID# | NCDOT Inv # | Name | Location | Latitude | Longitude | Manufacturer | Model # |
|--------------|-------------|---------------------------------|--|----------|-----------|--------------|-------------------------------------|
| | 05-0134 | Equipment Cabinet | US 70 at Raynor Rd./ Auburn-Knightdale | -78.5500 | 35.6873 | McCain | Type-332 |
| | | Junction Box # 1 (Phase 2 Side) | US 70 at Raynor Rd./ Auburn-Knightdale | -78.5516 | 35.6879 | Quazite | PG1118BA12(Box) PG118HA00(Cover) |
| | | Junction Box # 2 (Phase 2 Side) | US 70 at Raynor Rd./ Auburn-Knightdale | -78.5506 | 35.6876 | Quazite | PG1118BA12(Box) PG118HA00(Cover) |
| | | Junction Box # 3 (Near Cabinet) | US 70 at Raynor Rd./ Auburn-Knightdale | -78.5501 | 35.6873 | Quazite | PG1118BA12(Box) PG118HA00(Cover) |
| | | Junction Box # 4 (Phase 6 Side) | US 70 at Raynor Rd./ Auburn-Knightdale | -78.5486 | 35.6873 | Quazite | PG1118BA12(Box) PG118HA00(Cover) |
| | | Junction Box # 5 (Phase 6 Side) | US 70 at Raynor Rd./ Auburn-Knightdale | -78.5493 | 35.6876 | Quazite | PG1118BA12(Box) PG118HA00(Cover) |
| | | Junction Box # 6 (Phase 4 Side) | US 70 at Raynor Rd./ Auburn-Knightdale | -78.5503 | 35.6879 | Quazite | PG1118BA12(Box) PG118HA00(Cover) |

8.4. MEASUREMENT AND PAYMENT

Junction box (_____) will be measured and paid in actual number of junction boxes of each size and type furnished, installed, and accepted.

No measurement will be made of covers for new junction boxes, washed stone, removal of existing junction boxes and grounding systems as these will be considered incidental to furnishing and installing junction boxes.

No measurement will be made of restoration of paved roadways/driveways and unpaved ground surfaces with like materials, including but not limited to backfill, washed stone, paved materials, seeding and mulching, as this work will be considered incidental to junction box installation. The Department will make no payment for a given junction box until all repairs to paved and unpaved surfaces damaged/disturbed during the installation of the junction box have been completed and accepted.

◆ **Revision No. 1, April 10, 2017 – This document supersedes version originally issued and sealed by J. Todd Brooks, NCPE No. 017586 on 12/28/2016.**

U-4715B

ITS-102

Buncombe County

Repair and replacement of existing sidewalk will be measured and paid for in accordance with the “Equipment Cabinet Foundations” section of these Project Special Provisions.

No measurement will be made of collecting and recording GPS coordinates for junction boxes and compiling this data in the prescribed Microsoft Excel spreadsheet as such work will be considered incidental to furnishing and installing junction boxes.

Payment will be made under:

| Pay Item | Pay Unit |
|---------------------------------------|-----------------|
| Junction Box (Standard Size) | Each |
| Junction Box (Over-Sized, Heavy Duty) | Each |
| Junction Box (Special-Sized) | Each |

9. BEAUCATCHER TUNNEL CONDUIT SYSTEM

9.1. DESCRIPTION

Furnish and install a new conduit system through Beaucatcher Tunnel to provide a raceway through the tunnel for installation of fiber-optic communications cable as shown in the Plans.

9.2. MATERIALS

A. Surface Mounted Junction Boxes

Provide surface-mounted metal junction boxes at locations shown in the Plans to facilitate the pulling of fiber-optic communications cable through the new conduit system and to store a coil of slack fiber-optic communications cable. Provide a junction box with the following features:

- NEMA Type 4X enclosure fabricated from galvanized or stainless steel (16 gauge or better) with a bright galvanized, natural mill finish stainless steel or gray polyester powder-coated exterior finish.
- Have seam-free front, sides and back.
- Have a solid galvanized or stainless steel front cover that is either hinged or removable, with the same exterior finish as the remainder of the enclosure, and that is secured to the enclosure by a stainless or plated steel screws. If cover is hinged, provide a stainless steel continuous hinge (16 gauge or better) with a stainless steel pin.
- Can accommodate up to two conduit entrances up to 2" in nominal diameter in both the top and the bottom of cabinet.
- Can accommodate a single conduit entrance on two opposite sides of the enclosure for attachment of a 1.25" RGS conduit.
- Sized to accommodate pulling of fiber-optic communications cable and storage of slack cable at no less than the manufacturer's specified minimum bend radius (loaded and unloaded) for the cable and having minimum dimensions of 16" (w) x 16" (h) x 6" (d).
- Have a minimum of four (4) mounting holes on the back of the enclosure, two along the top and two along the bottom, to enable enclosure to be attached to the surface of the tunnel using appropriate concrete anchors.

Furnish the junction box with all fasteners, anchors, brackets and mounting hardware required to mount the box securely to concave surface of the interior concrete wall of the tunnel wall.

B. Conduit, Conduit Bodies, Conduit Fasteners and Fittings

Furnish all conduit, conduit fittings, outlet bodies, conduit straps, conduit fasteners and any other hardware required to provide a conduit system to convey a fiber-optic communications cable through Beaucatcher Tunnel as shown in the Plans. Use rigid galvanized steel conduit materials that comply with the "Riser Assemblies" and "Underground Conduit" sections of these

◆ **Revision No. 1, April 10, 2017 – This document supersedes version originally issued and sealed by J. Todd Brooks, NCPE No. 017586 on 12/28/2016.**

U-4715B

ITS-104

Buncombe County

Project Special Provisions. Use conduit bodies and covers that are fabricated of hot dip galvanized iron or iron alloy.

C. Concrete Anchors

Furnish screw anchors or expansion anchors for securely attaching conduit straps, surface mounted pull boxes and mounting bracket to the concrete lining of Beaucatcher Tunnel. Provide anchors that are designed for outdoor installation in concrete, that are vibration resistant, that are fully-removable and that are appropriately size to secure conduit or junction box to the tunnel wall. Submit the manufacturer's literature/product specifications for the proposed anchors to the Engineer for review and approval prior to installation.

D. Concrete for Sidewalk Repair/Replacement

Furnish high early strength Portland cement concrete that complies with Article 1000-5 of the *Standard Specifications* for sidewalk repair and replacement.

9.3. CONSTRUCTION METHODS

A. General

Perform all work called for in the Plans to construct a new conduit system through Beaucatcher Tunnel and to route new fiber-optic communications cable through the new conduit system. Perform all work in accordance with NESC regulations and guidelines.

The Department has a project planned to convert the existing tunnel light fixtures to LED light fixtures. Work on this lighting system upgrade may overlap with construction of the proposed conduit system through the tunnel. Contact Desmond Jamerson, NCDOT Division 13 Traffic Services Supervisor, at (828) 298-0094 at least 30 days in advance of work to confirm work schedule and work restrictions and to coordinate work activities with the lighting system upgrade project. Coordinate and cooperate with the contractor performing the lighting system upgrades.

Provide temporary traffic control as shown in the Plans and in accordance with the "Temporary Traffic Control" section of these Project Special Provisions. Make reasonable efforts to schedule and perform the installation of the conduit system concurrent with the tunnel system lighting upgrades to combine temporary traffic control measures and thereby minimize disruptions to vehicular and pedestrian traffic flow and inconvenience to the traveling public.

Construct the conduit system so that it will not violate the fiber-optic cable manufacturer's recommended minimum bend radius during and after installation of the cable in the conduit system.

For vertical runs of conduit, bend the conduit to match the curvature of the tunnel wall so that conduit rests against (i.e., is in continuous contact with) the surface of the wall with no gaps between the conduit and the wall.

To reduce the number of new holes drilled into the tunnel wall, use one of the four screw anchors installed through the bottom flange of each existing light bracket to secure one end of the new conduit strap for the new 1.25" RGS conduit as shown in the Plans. Carefully remove one of the existing anchors, align the hole of the conduit strap over the vacant hole in the light bracket, then reinstall the screw anchor to secure both the conduit strap and the light bracket with same, shared anchor. If the existing screw anchor is damaged or not long enough to pass through

◆ **Revision No. 1, April 10, 2017 – This document supersedes version originally issued and sealed by J. Todd Brooks, NCPE No. 017586 on 12/28/2016.**

U-4715B**ITS-105****Buncombe County**

both the conduit strap and light bracket with sufficient embedment length in the wall to anchor securely, replace the existing screw anchor with an equivalent or better screw anchor of appropriate length. Do not remove more than existing screw anchor from each light bracket and do not remove the light bracket or disturb the light fixture. Secure the horizontal segments of conduit to the wall by installing a conduit strap at each light fixture and at least one conduit strap midway between each light fixture.

Install two surface-mounted junction boxes in-line with the conduit at locations shown in the Plans to facilitate pulling of the new communications cable and provide slack cable storage. Coil and store 10 LF of fiber-optic communications cable in each surface mounted junction box.

Hand-feed/pull the fiber-optic communications cable through new conduit system; do not use mechanical means to pull the cable through the new conduit system. Comply with the "Communications Cable" section of these Project Special Provisions when installing the communications cable.

Use high early strength Portland cement concrete for replacement and repair of all sidewalk inside the tunnel and on the approaches to the tunnel immediately following the installation of conduit and in-sidewalk junction boxes. Reopen sidewalk to pedestrian traffic within 24 hours of placement of high early strength concrete.

Do not leave ends of conduits sticking up in sidewalks at the end of the work period. Immediately install proposed junction boxes at ends of conduit runs and before reopening the sidewalk to pedestrians.

Ensure that the tops of junction boxes are even with the surface of the surrounding sidewalk and that junction box covers are installed before reopening the sidewalk to pedestrians.

9.4. MEASUREMENT AND PAYMENT

Surface-mounted junction box will be measured and paid as the actual number of surface-mounted junction boxes furnished, installed and accepted.

Wall-mounted conduit (size) will be measured in linear feet of wall-mounted conduit of each size furnished, installed, and accepted. Measurement will be along the approximate centerline of the conduit system, both vertically and horizontally, and will be made above-ground segments only. Payment will be in linear feet.

No separate measurement will be made for mounting hardware, nuts, bolts, washers, anchors, replacement screw anchors, brackets, connectors, conduit fittings and outlet bodies and conduit straps as these will be considered incidental to furnishing and installing surface-mounted pull boxes and wall-mounted conduit.

Concrete sidewalk will be measured and paid for in accordance with the "Equipment Cabinet Foundation" section of these Project Special Provisions. No additional payment will be made for use of high early concrete when required by the Plans, these Project Special Provisions and per the direction of the Engineer.

Temporary traffic control devices and measures required to maintain both vehicular pedestrian traffic on Tunnel Road/College Street while constructing the conduit system and installing the fiber-optic communications system will be measured and paid in accordance with the "Temporary Traffic Control" section of these Project Special Provisions.

◆ **Revision No. 1, April 10, 2017 – This document supersedes version originally issued and sealed by J. Todd Brooks, NCPE No. 017586 on 12/28/2016.**

U-4715B

ITS-106

Buncombe County

Fiber-optic communications cable, underground conduits and in-ground junction boxes will be measured and paid in accordance with the “Communications Cable”, “Underground Conduit” and “Junction Boxes” sections of these Project Special Provisions respectively.

Payment will be made under:

Pay Item

Pay Unit

Surface-Mounted Junction Box

Each

Wall-Mounted Conduit (1.25”)

Linear Foot

10. EXTENSION OF EXISTING FIELD WIRING AT CONTROLLER CABINETS

10.1. DESCRIPTION

Furnish and install terminal splice cabinets to splice and extend existing signal and loop lead-in cables (i.e., field wiring) to new controller cabinets. Furnish and install gel-filled splice connectors to splice and extend existing conductors inside new controller cabinets.

10.2. MATERIALS

A. Terminal Blocks

Provide terminal block (i.e., terminal strips) constructed of electrical grade thermoplastic or thermosetting plastic with the terminals recessed between molded barriers for splicing and extending existing field wiring. Provide terminal blocks with the number of terminals required in these provisions or with a sufficient number to accommodate splicing and extending of incoming existing field wiring conductors. Each terminal shall have two terminal screws that have a minimum outside diameter of 3/16 inches. A removable shorting bar shall be provided between the screws of each terminal. Both the screws and shorting bar shall be made of corrosion resistant nickel-plated brass. Provide separate terminal blocks for signal conductors and loop lead-in conductors.

B. Terminal Splice Cabinets

Provide NEMA Type 3 or Type 4 enclosures fabricated of sheet steel or sheet aluminum with continuous weld construction and with a drip shield top. The steel enclosures shall be stainless steel. Aluminum enclosures shall have a standard mill finish.

Provide an enclosure with a terminal block having at least 20 terminals with each terminal having two terminal screws. Mount the terminal block on the back wall of the enclosure in such a manner that no mounting screws, nuts, etc., protrude through the enclosure. Center the terminal block both horizontally and vertically on the back wall of the enclosure in line with the long dimension of the enclosure. Install additional terminal blocks as necessary.

Provide an enclosure of sufficient size to accommodate entrances for a minimum of four 2-inch galvanized rigid metal conduits in the bottom of the enclosure. The dimensions of the enclosure shall not be less than 16" wide x 20" high x 8" deep. The enclosure shall have a hinged front door which opens to the side and which is secured by a Corbin No. 2 lock and latch. A door handle is not required.

Provide conduit entrances in the bottom of the cabinet only which are of the size and number required for the specific location where cabinet will be installed. Conduit entrances in the top or sides of the cabinet are prohibited. Conduit entrances may be either pre-drilled or field-drilled, but shall not exceed the number required for the location. Extra or spare entrances, capped or otherwise, are not acceptable. Field-verify the required number, size and position of entrances prior to drilling.

Provide all necessary hardware and mounting brackets for attaching the terminal splice cabinet on the pole. Such hardware shall provide for mounting the cabinet to metal or wood signal poles using at least two stainless steel bands (straps) of the size recommended by the manufacturer, one near the top of cabinet and one near the bottom.

◆ **Revision No. 1, April 10, 2017 – This document supersedes version originally issued and sealed by J. Todd Brooks, NCPE No. 017586 on 12/28/2016.**

U-4715B**ITS-108****Buncombe County**

Furnish rigid galvanized conduit, fittings and conduit outlet bodies along with new pull boxes where required to replace existing short risers. Use conduits, fittings and conduit outlet bodies of same nominal size as the existing short risers being replaced. Furnish conduit fittings and outlet bodies as required to install existing risers into base of new terminal splice cabinet.

C. Gel-Filled Splice Connectors

Furnish gel-filled connectors of the appropriate wire gauge to butt splice and extend the existing conductors of signal cables and loop lead-in cables inside controller cabinets.

D. Signal Cable and Loop Lead-In Cable

Furnish new traffic signal cables and loop lead-in cables for extending existing cables from new terminal splice cabinet. Furnish equivalent size conductor signal cable. Furnish loop lead-in cable which complies with the "Lead-In Cable" section of these Project Special Provisions. Furnish new conductors and new cables that match the insulation color coding of the conductors in the existing cables to which they are being spliced.

10.3. CONSTRUCTION METHODS

A. General

Prior to splicing and extending existing conductors or rerouting existing conductors through new conduits and risers, place permanent labels on all incoming and outgoing conductors in the controller cabinet using a naming convention such as Phase 1 Green, Phase 2 Yellow, Loop 2A, etc., unless the conductors are already labeled. Where there are existing labels on the conductors, confirm that they are labeled correctly and replace any labels that are incorrect.

Place similar permanent labels on the ends of all new conductors used to extend the existing conductors.

Perform standard megger tests on loops after splicing and extending loop lead-ins. Upon approval of the Engineer, replace lead-in cables or loop and lead-in cable assemblies that do not pass standard megger tests.

Maintain the color coding of individual conductors through the splice. Splice and extend existing conductors using new conductors with the same insulation color. Do not splice together conductors with different color insulation.

B. Inside Controller Cabinets

Where a new controller cabinet is being mounted over existing conduit stubouts on an existing foundation or over existing riser bases at a pole-mounted location and the existing field wiring will not reach the terminal blocks provided inside the new cabinet, splice and extend the incoming and outgoing signal and loop lead-in conductors inside the controller cabinet using gel-filled butt splice connectors.

C. External to Controller Cabinets

Where new controller cabinets are being installed in a different location from the existing cabinet location and the Plans do not call for re-cabling of the intersection, install, as shown on the Plans, a terminal splice cabinet to splice and extend existing signal and loop lead-in conductors as required to reach the new controller cabinet through new risers and conduits.

◆ **Revision No. 1, April 10, 2017 – This document supersedes version originally issued and sealed by J. Todd Brooks, NCPE No. 017586 on 12/28/2016.**

Do not splice and extend conductors external to the controller cabinet where the existing field wiring is of sufficient length to reach the new cabinet in its new location. An example would be where the Plans call for the new cabinet to be placed on a new foundation located at the same or lesser distance from the adjacent signal pole as the existing base-mounted cabinet and foundation. At such locations, pull the existing cables out of the existing cabinet, risers and conduit and reroute them to the new cabinet via the new risers and conduits.

Use a terminal splice cabinet when an existing pole-mounted cabinet is being replaced with a new base-mounted cabinet and the Plans do not call for re-cabling the intersection. Use a terminal splice cabinet where an existing base-mounted cabinet is being replaced with a new base-base mounted cabinet on a new foundation in a new location and the existing cabling is not long enough to reach the base of the new cabinet and the Plans do not call for re-cabling the intersection.

Do not route electrical service wire through the terminal splice cabinet.

D. Terminal Splice Cabinets

Disconnect the conductors from the existing cabinet, remove the existing pole-mounted controller cabinet, but retain the existing risers, conduit outlet bodies and cables housed therein. Install the new terminal splice cabinet on the pole at same location as removed cabinet with bottom of splice cabinet at the same vertical height as the bottom of the removed cabinet. Install conduit entry holes into base of new cabinet and attach existing risers. Adjust existing conduits and modify/add conduit outlet bodies as necessary to attach to new cabinet. Splice the existing signal cables and loop lead-in cables to the new cables on the terminal splice block and extend new signal cables and new lead-in cables to new base mounted cabinet via two separate, new 2-inch rigid galvanized short risers and underground conduits as shown in the Plans. Use 16-14 AWG insulated solderless crimp terminals on the ends of conductors being spliced. Install the terminals with a ratcheting-type crimp tool. Bond the terminal splice cabinet to the equipment ground in the controller cabinet using a 14 AWG stranded THHN copper wire with green insulation. Do not put loop grounds and other grounds with neutral conductors.

At certain intersections with existing pole-mounted controller cabinets, existing lead-in cables or pedestrian signal cables are routed underground to existing pole-mounted cabinets and enter the bottom of existing cabinet via a short riser. A short riser is defined as a short section of vertical conduit between the bottom of a pole-mounted cabinet and the ground below that conveys cables between an underground conduit and the cabinet. Where these short risers are attached to the face of the pole, attach the short riser into a conduit entrance on the bottom of the new terminal splice cabinet and splice the existing cables to the new cables on the terminal block in the cabinet.

Where the existing short riser is “freestanding” (i.e., it is offset horizontally more than one inch from the face of the signal pole and is not secured to the face of the signal pole) or is damaged (i.e., crimped or severely bent), replace the existing short riser with a new short riser attached to the face of the pole as shown in the Plans. Feed the existing cables through the new conduit and short riser and into the new terminal splice cabinet. Splice the existing conductors to the new conductors on the terminal block.

U-4715B

ITS-110

Buncombe County

E. Terminal Splice Cabinet Where Existing Cabinet is Base-Mounted

Mount the terminal splice cabinet on the pole with the center of the cabinet 48 inches above the ground at the base of the pole. Install new risers to the terminal splice cabinet and short risers from the terminal splice cabinet to the underground conduits leading to the new controller cabinet foundation. Disconnect field wiring from existing base-mounted controller cabinet, carefully pull the cables out of the tops of the existing risers and reroute the existing cables through new risers to a terminal splice cabinet. Splice the existing signal cables and loop lead-in cables to the new cables on the terminal splice block and extend new signal cables and new lead-in cables to new base mounted cabinet via two separate, new 2-inch rigid galvanized short risers and underground conduits as shown in the Plans. Use 16-14 AWG insulated solderless crimp terminals on the ends of conductors being spliced. Install the terminals with a ratcheting-type crimp tool. Bond the terminal splice cabinet to the equipment ground in the controller cabinet using a 14 AWG stranded THHN copper wire. Do not put loop grounds and other grounds with neutral conductors.

Where a loop lead-in cable or pedestrian signal cable enters the existing cabinet foundation directly via an existing underground conduit instead of through a riser, take care to protect the existing cables and the conduit stubout so as not to damage them when removing the existing controller cabinet and its existing foundation. Pull the cables back out of the foundation stubouts from a junction box, handhole, or transformer base, if available, before removing the cabinet foundation. Upon removal of the cabinet foundation, install a junction box over the conduit stubouts and install new underground conduit(s) from the junction box to a stubout in the new cabinet foundation. Splice the loop lead-in cable to new lead-in cable in the junction box in accordance with *Roadway Standard Drawing No. 1725.01* and run the new lead-in cable from the junction box directly to the new controller cabinet via the new underground conduit. Do not splice and extend existing pedestrian signal cable. Remove the existing pedestrian signal cable and install new, continuous pedestrian signal cable from the pedestrian signal to the new controller cabinet via the existing and new underground conduits.

Where these short risers are attached to the face of the pole, attach the short riser into a conduit entrance on the bottom of the new terminal splice cabinet and splice the existing cables to the new cables on the terminal block in the cabinet.

10.4. MEASUREMENT AND PAYMENT

Terminal Splice Cabinet will be measured and paid for as the actual number of terminal splice cabinets, furnished, installed, and accepted.

No measurement will be made of new full-height risers attached to the bottom of terminal splice cabinet as these will be considered incidental to furnishing and installing terminal splice cabinets.

No measurement will be made of replacement of existing conduit bodies and fittings, and installation of new conduit bodies and fittings as these will be considered incidental to furnishing and installing terminal splice cabinets.

No measurement will be made of new short risers that replace of existing short risers as they will be considered incidental to furnishing and installing terminal splice cabinets.

◆ **Revision No. 1, April 10, 2017 – This document supersedes version originally issued and sealed by J. Todd Brooks, NCPE No. 017586 on 12/28/2016.**

U-4715B**ITS-111****Buncombe County**

When required to intercept existing underground conduit, new junction boxes will be paid for in accordance with the “Junction Boxes” section of these Project Special Provisions as approved by the Engineer.

No measurement will be made of additional signal cable/conductors and loop lead-ins, as the splicing of all existing signal conductors and loop lead-ins in the splice cabinet, extending them through new risers and conduits and connecting them to the new controller cabinet will be considered incidental to furnishing and installing terminal splice cabinets.

No measurement will be made of gel-filled splice connectors and additional signal and loop lead-in cable/conductors as the splicing and extending of conductors inside the controller cabinet will be considered incidental to furnishing and installing the new controller and cabinet.

No measurement will be made of testing of loops after splicing and extending lead-in cables as performing standard megger tests will be considered incidental to splicing and extending the lead-in cables.

Engineer-approved replacement of loops will be measured and paid as provided for under *Inductive Loop Sawcut* in accordance with the “Inductive Detection Loops” section of these Project Special Provisions. Engineer-approved replacement of loop lead-ins will be measured and paid as provided for under *Lead-In Cable* in accordance with the “Lead-In Cable” section of these Project Special Provisions.

Payment will be made under:

| Pay Item | Pay Unit |
|-------------------------|-----------------|
| Terminal Splice Cabinet | Each |

U-4715B

ITS-112

Buncombe County

11. WOOD POLES

11.1. DESCRIPTION

Furnish and install wood poles with grounding systems and all necessary hardware for the mounting of CCTV camera assemblies and wireless communications antennas and radios.

11.2. MATERIALS

A. General

Material, equipment, and hardware furnished under this section shall be pre-approved on the ITS and Signals QPL.

Furnish treated timber poles that meet the requirements of ANSI O5.1, except the timber shall be treated Southern Pine or treated Douglas Fir.

Treat poles in accordance with AWPA Standard U1, except require retention of preservative as below.

Give all poles a preservative treatment of either pentachlorophenol, or chromated copper arsenate. The same type of preservative shall be used throughout the entire length of the project.

Minimum retention for poles treated with pentachlorophenol will be 0.45 lb. by assay of dry chemical per cubic foot of wood. Minimum retention for poles treated with chromated copper arsenate will be 0.6 lb. by assay of dry chemical per cubic foot of wood.

Refer to the following sections of the *Standard Specifications*:

- 1091-6, "Grounding Electrodes"
- 1082, "Inspection Requirements"
- 1091-2, "Wire and Cable"
- 1082, "Structural Timber and Lumber"

B. Wood Poles for Antennas

Furnish Class 3 or better wood poles that have a minimum length of 40 feet for mounting wireless communications antennas and pole-mounted cabinets.

C. CCTV Wood Poles

Furnish Class 3 or better wood poles to mount CCTV cameras and cabinets that are of sufficient length to permit the CCTV camera to be mounted at the mounting height specified in the Plans. To provide for CCTV camera mounting heights of up to 35 feet above the ground at the base of the pole, furnish CCTV wood poles that are at least 50 feet in length. The Contractor is encouraged to visit the site of the proposed CCTV poles to confirm the length of pole required to attain the specified mounting prior to ordering the CCTV poles.

11.3. CONSTRUCTION METHODS

Install poles at locations shown on the Plans. Except where the Plans specify an exact location (i.e., show offsets and dimensions from known points), place the pole at an offset from the edge of travel way that is consistent with other fixed objects and utility poles along that side of the road, but in no case closer than 1.5 feet from the face of curb. Within intersection radii, install poles a minimum of 7 feet behind face of curb or 10 feet from the edge of travel way

◆ **Revision No. 1, April 10, 2017 – This document supersedes version originally issued and sealed by J. Todd Brooks, NCPE No. 017586 on 12/28/2016.**

where there is no curb. If the Plans do not specify an exact locations, the pole is not within the intersection radius and there are no other poles along the side of the road where the pole is to be installed, locate the pole as far as practical from the edge of the roadway, using the setback distances in the following table as a guide:

| Speed Limit | Desirable Minimum Setback Distance | |
|-------------|--|---|
| | from face of curb in curb & gutter section | from edge of travel way in shoulder section (no curb) |
| ≤ 25 mph | 8 feet | 10 feet |
| 30-35 mph | 10 feet | 12 feet |
| 40 mph | 12 feet | 16 feet |
| 45 mph | 16 feet | 18 feet |
| 50 mph | 20 feet | 22 feet |
| 55 mph | 22 feet | 24 feet |
| ≥ 60 mph | n/a | 30 feet |

Measure the setback distance from the face of curb or edge of travel lane to the face of the pole.

Field conditions and site specific constraints may require the pole to be located at setback distances less than those listed above, subject to the approval of the Engineer.

Mark final pole locations and receive approval from the Engineer before installing poles.

Ensure poles are of sufficient length to maintain the minimum required clearances above the roadway, obstructions, and affected railroad tracks

Drill or auger a hole for placement of pole and to allow for compacting. Set poles for signals and aerial cable routes at the manufacturer's recommended depth or at a depth equal to 10% of the pole length plus 2 feet, whichever is greater, but in no case less than of 5 feet deep. Set CCTV wood poles at a minimum depth of 10 feet. Ensure the pole is within 2 degrees of vertical when fully loaded.

Backfill hole with pole installed and tamp backfill in 6 inch lifts with a mechanical tamp until compacted density is at least 95% of original density.

Install the CCTV pole grounding system as shown in the Plans.

For all other new Department-owned or City-owned poles, install a grounding system consisting of #6 AWG solid bare copper wire that is exothermically welded to a single ground

◆ **Revision No. 1, April 10, 2017 – This document supersedes version originally issued and sealed by J. Todd Brooks, NCPE No. 017586 on 12/28/2016.**

U-4715B**ITS-114****Buncombe County**

rod installed at the base of the pole or to the electrical service grounding electrode system located within 10 feet of the pole. Install ground wire so as to minimize damage from vandalism and environmental exposures. Install ground wire up pole to a point adjacent to the uppermost span. Use hot-dipped galvanized 1.5” wire staples to secure ground wire to pole, spacing the staples along the ground as follows:

- 4 inches apart from ground level to 8 feet above ground level;
- 24 inches apart from 8 feet above ground level to point adjacent to uppermost span.

11.4. MEASUREMENT AND PAYMENT

Wood pole will be measured and paid for as the actual number of wood poles furnished, installed, and accepted.

CCTV wood pole will be measured and paid for as the actual number of CCTV wood poles of furnished, installed, and accepted regardless of length.

Ground rods installed as part of pole grounding systems will be measured and paid for in accordance with the “Electrical Service” section of these Project Special Provisions. No measurement will be made for furnishing and installing #6 AWG solid bare copper wire, messenger bonding clamps, hot-dipped galvanized wire staples, and exothermic welding as part of pole grounding systems as such work will be considered incidental to furnishing and installing the wood poles, messenger cable and grounding electrodes.

Payment will be made under:

| Pay Item | Pay Unit |
|-----------------|-----------------|
| Wood Pole | Each |
| CCTV Wood Pole | Each |

12. GUY ASSEMBLIES

12.1. DESCRIPTION

Furnish and install guy assemblies with all necessary hardware.

12.2. MATERIALS

Material, equipment, and hardware furnished under this section shall be pre-approved on the ITS and Signals QPL.

Furnish guy assemblies with anchor assemblies, guy cable, and guy cable guard.

Provide anchor assemblies with all miscellaneous hardware consisting of either expanding anchor with rod and triple-eye attachment, screw anchor with extension rod and triple-eye attachment, or expanding rock anchor with triple-eye attachment. Ensure anchor assembly size is adequate for site conditions. Provide rods constructed of hot-dipped galvanized steel sized according to the soil bearing conditions in the area. Provide triple-eye guy attachments constructed of hot-dipped galvanized steel. Anchor assemblies with double-strand eyes may be used in lieu of those with the triple-eye feature when only one guy cable is to be attached. Ensure anchor assemblies are 7 feet minimum in length.

For type of anchor assembly furnished, ensure the following:

1) Expanding Anchor

Provide steel construction with protective paint or heat shrink of 6 mil plastic to protect metal during shipping and storage.

2) Screw Anchor

Provide hot-dipped galvanized steel construction.

3) Expanding Rock Anchors

Provide malleable iron and rust-resisting paint construction.

Provide 3-bolt clamp to match messenger cable size.

Provide full round guy cable guards that are 8 feet in length and constructed of ultraviolet (UV) stabilized, high impact, bright yellow, high density polyethylene (HDPE).

Provide guy cables consisting of messenger cable of the same size as the largest sized messenger cable to be guyed. Comply with the "Messenger Cable" section of these Project Special Provisions.

Refer to the "Pole Line Hardware" subsection of the "Messenger Cable" section of these Project Special Provisions.

12.3. CONSTRUCTION METHODS

A. General

Comply with *Roadway Standard Drawing* (RSD) No. 1721.01 when constructing guy assemblies.

B. Guy Assemblies for Signal Heads or Loop Lead-in Cable

Install guy assemblies with guy cable, guy guards, anchors, three-bolt clamps and associated fittings. Use two-bolt attachment method where there is adequate room on the pole to comply

◆ **Revision No. 1, April 10, 2017 – This document supersedes version originally issued and sealed by J. Todd Brooks, NCPE No. 017586 on 12/28/2016.**

U-4715B

ITS-116

Buncombe County

with the NESC. Attach guy assembly and guy cable to two separate bolts with one bolt for span and one bolt for guy cable.

Where adequate spacing is not available and a violation of the NESC would occur with the two-bolt attachment method, use approved one-bolt attachment method for attaching messenger cable and guy assembly.

Bond guy assembly to existing pole ground and to the messenger cable using parallel groove clamp or equivalent. If existing City or NCDOT poles do not have a grounding system, install a grounding system in accordance with the "Wood Poles" section of the *Standard Specifications*.

Do not use guy anchors as grounding electrodes.

Do not attach to existing guy assemblies unless specifically approved by owner.

When proposed guy assembly replaces an existing guy assembly, remove the existing guy assembly, including guy anchor if not reused for the new guy assembly.

C. Guy Assemblies for Communications Cable

When installing messenger cable for supporting only communications cable, use approved one-bolt attachment method for attaching messenger cable and guy assembly.

Bond guy assembly to existing pole ground and to the messenger cable using parallel groove clamp or equivalent. If existing City or NCDOT poles do not have a grounding system, install a grounding system in accordance with the "Wood Poles" section of the *Standard Specifications*, except use hot-dipped galvanized 1.5" wire staples to secure ground wire to pole, spacing the staples along the pole as follows:

- 4 inches apart from ground level to 8 feet above ground level;
- 24 inches apart from 8 feet above ground level to point adjacent to uppermost span.

Do not use guy anchors as grounding electrodes. Do not attach to existing guy assemblies unless specifically approved by owner.

When proposed guy assembly replaces an existing guy assembly, remove the existing guy assembly, including guy anchor if not reused for the new guy assembly.

12.4. MEASUREMENT AND PAYMENT

Guy assembly will be measured and paid as the actual number of direct down guy (i.e., standard guy) assemblies furnished, installed, and accepted.

Guy assembly (____) will be measured and paid as the actual number of guy assemblies of each type (aerial or sidewalk) furnished, installed, and accepted.

No measurement will be made of guy cable, guy guards, anchors, clamps, grounding systems, strandvises, 2" galvanized pipe, pole plates, other fittings, or the removal of existing guy assemblies as these will be considered incidental to furnishing and installing guy assemblies.

U-4715B

ITS-117

Buncombe County

Payment will be made under:

| Pay Item | Pay Unit |
|-------------------------|-----------------|
| Guy Assembly | Each |
| Guy Assembly (Aerial) | Each |
| Guy Assembly (Sidewalk) | Each |

13. RISER ASSEMBLIES

13.1. DESCRIPTION

Furnish and install riser assemblies with clamp-on, aluminum weatherheads, heat shrink tubing, temporary pipe caps, PVC adapters, galvanized pole attachment fittings, stainless steel banding hardware, grounding and all necessary hardware.

13.2. MATERIALS

Furnish material, equipment, and hardware furnished under this section that is pre-approved on the ITS and Signals QPL.

Provide conduit for risers that is rigid hot dipped galvanized steel conduit that meets UL Standard 6 with rigid full weight sherardized or galvanized threaded fittings.

Refer to the following sections of the *Standard Specifications*:

- 1091-6, "Grounding Electrodes"
- 1091-2, "Wire and Cable"

In addition, refer to the "Pole Line Hardware" subsection of the "Messenger Cable" section of these Project Special Provisions.

Provide Schedule 40 PVC female adapter to connect an underground run of PVC conduit to the threaded end of a rigid metallic. Provide PVC female adapters that have the same nominal diameter as the underground conduit.. The interior surface of one end of the PVC female adapter shall be compatibly threaded to connect it to the threaded end of the rigid metallic riser without the aid of additional fittings, hardware or adhesives. The opposite end of the adapter shall be non-threaded to permit a slip fit, glued connection to the underground PVC conduit.

Furnish appropriately sized clamp-on aluminum weatherheads for electrical control and power cables.

Furnish heat shrink tubing for the installation of fiber-optic or coaxial cable in a new riser. Ensure the heat shrink tubing is made of modified polyolefin and includes a hot-melt adhesive. Provide tubing that has a length of at least 5" before heating. Ensure the heat shrink tubing will provide a watertight fit around individual cables and outer wall of the riser after heat is applied in accordance with the manufacturer's instructions.

Furnish heat shrink tubing retrofit kits for the installation of fiber-optic cable or coaxial cables to an existing riser with existing cables. Ensure the heat shrink material is made of modified polyolefin and is supplied in a flat sheet design. Ensure the kit contains an apparatus to secure both ends of the flat sheet together to form a tube shaped cylinder. Ensure the securing apparatus is flexible to the point that it will allow the heat shrink material to conform to the shape and dimensions of the riser and cables once heat is applied and will not separate during the heating process. Provide heat shrink tubing retrofit kits with a hot-melt adhesive. Provide the flat sheet heat shrink material that has a minimum length of 5" prior to heating. Ensure the heat shrink tubing retrofit kit provides a watertight fit around individual cables and outer wall of the riser after heat is applied in accordance with the manufacturer's instructions.

◆ **Revision No. 1, April 10, 2017 – This document supersedes version originally issued and sealed by J. Todd Brooks, NCPE No. 017586 on 12/28/2016.**

U-4715B**ITS-119****Buncombe County**

Furnish all new 1.25" and 2" risers that will house fiber-optic communications cable with temporary pipe caps to seal the top of the riser and prevent rain from falling into riser until fiber-optic cable can be installed in the riser and heat-shrink tubing applied to the top of the riser. Provide riser caps constructed from heat-stabilized vinyl that fit snugly over the end of the end of the riser and that will not be easily dislodged by wind following installation. Furnish caps designed to remain in place through physical contact friction and that do not use adhesives or screws to remain securely in place. Provide caps sized to fit over each diameter (i.e., 1.25" and 2") of rigid galvanized conduit used for fiber-optic communications cable risers on this project.

Where risers for fiber-optic communications cable, antenna cables and composite cables for CCTV will be attached to black or dark green metal poles in downtown Asheville and in Biltmore Village, provide rigid galvanized risers that are coated to match the color of the metal pole to which they will be attached. Provide riser assemblies with either a powder coated finish or have a Contractor-applied painted finish. Submit the manufacturer's literature and application instructions for the proposed powder coating or paint system to the Engineer for approval prior to application. For Contractor-applied paint finish, use a durable, exterior latex-acrylic paint system that is compatible with and designed to adhere permanently to a galvanized steel surface. Provide paint that dries to a satin finish. Prepare the galvanized steel surface to receive paint following the recommendations of the American Galvanizers Association (www.galvanizeit.org) as well as the paint manufacturer's instructions. Remove all surface contaminants by washing with a manufacturer recommended detergent or degreaser, then apply a wash primer (i.e., etch primer). Apply the paint following application of the wash primer. Apply the coating to all exterior surfaces of the enclosure indoors in a controlled environment in accordance with the paint manufacturer's instructions. Do not paint riser assemblies in the field or after installation. Only touch-up paint may be field-applied, as necessary and as approved by the Engineer, following installation.

13.3. CONSTRUCTION METHODS

Install risers with required weatherheads or heat shrink tubing on poles using pole attachment fittings and, on metal poles, stainless steel banding hardware. Maintain a 10" minimum and 18" maximum offset from signal messenger to the top riser for all risers. On utility-owned poles, maintain a 40" offset from the electrical utility's power conductors to top of riser and riser attachment fittings.

When installing risers that will house fiber-optic communications cable, immediately install a temporary pipe cap on the top of the riser to prevent rain from entering the riser until fiber-optic cable and heat-shrink tubing can be installed at a later time. Do not install risers if temporary caps cannot be installed at same time as risers. Do not install a communications cable riser and leave it uncapped/unsealed.

Use approved heat shrink tubing retrofit kits when installing new fiber-optic or coaxial cable into existing risers that contain existing fiber-optic or coaxial cables.

Install heat shrink tubing retrofit kits in existing risers as specified.

Use separate ½-inch riser with weatherhead for pedestrian pushbutton.

◆ **Revision No. 1, April 10, 2017 – This document supersedes version originally issued and sealed by J. Todd Brooks, NCPE No. 017586 on 12/28/2016.**

Use separate 1-inch riser with weatherhead for the following:

- Pedestrian signals;
- Electrical service;
- Composite cable routed to a CCTV camera from a CCTV cabinet; and
- CAT5 and 24V power cables routed between a CCTV cabinet and a nearby signal controller cabinet.

Use separate 2-inch risers with weatherheads for signal cables (bundled) and for lead-in cables. Install condulets on all risers for lead-in cable.

Use a separate riser with heat shrink tubing for fiber-optic communications cables and coaxial cable. For pole-mounted cabinets only, use 1.25-inch risers with heat shrink tubing for all new risers that will contain fiber-optic communications drop cables, unless the Plans call for use of a 2-inch riser with heat shrink tubing at a specific location. Connect 1.25-inch risers to the bottom of the pole-mounted cabinet using a pair of standard 90-degree elbows to form a 180-degree sweep up into the bottom of the cabinet. Standard 90-degree elbows for 1.25-inch conduit have a 7.25-inch radius and equal horizontal and vertical legs (i.e., offsets) that measure approximately 10.75 inches each. Smaller elbows are prohibited. Larger elbows may only be used if approved by the Engineer. Prior to installing fiber-optic cable in the 1.25-inch, drill a small “weep hole” on the underside of each elbow using a 3/16-inch drill bit to allow any water that may enter the riser to drain out of the riser. Clean any metal shavings and fragments from each hole and touch-up each newly drilled hole and its perimeter using a zinc-rich paint.

Use 1-inch and 2-inch risers with heat shrink tubing for coaxial cable for radio antennas as called for in the Plans.

For all other locations, use 2-inch risers with heat shrink tubing for fiber-optic communications cable. Install risers with heat shrink tubing so that cable can be installed without violating its minimum bending radius of the fiber-optic cable. Install fiber-optic cable so it does not share a riser with any other cable type.

Install heat shrink tubing in accordance with manufacturer's recommendations. Provide tubing a minimum of 5 inches in length with a minimum of 2.5 inches extended over cables and 2.5 inches extended over risers after heat has been applied. Use nylon filler rods with UV protection or equivalent and sealing spacer clips to separate cables where multiple cables enter a riser. Ensure sealing spacer clips have a heat activated sealing compound with the sealing compound fully encapsulating the space between cables. Ensure heat shrink tubing provides a watertight fit around individual cables and outer walls of risers. Do not use cut sections of cable or any other devices in lieu of filler rods. Use aluminum tape around cables to prevent damage from sealing chemicals. Use a heat source that will provide even heat distribution around tubing. Ensure no damage occurs to any cables. Do not use a heat source with an open flame.

Remove existing weatherheads, sealing bushings, heat shrink tubing and riser caps and install heat shrink tubing retrofit kits on existing risers according to the installation procedures above.

Transition from rigid galvanized steel risers to underground PVC conduits below ground using an approved rigid galvanized steel sweeping elbow with PVC female adapter, unless the Plans call for an above-ground transition. Apply Teflon thread tape to the threads of rigid galvanized steel sweeping elbow before screwing the PVC adapter onto the threaded end of the elbow. Connect the threaded female end of the PVC adapter to the threaded male end of the

◆ **Revision No. 1, April 10, 2017 – This document supersedes version originally issued and sealed by J. Todd Brooks, NCPE No. 017586 on 12/28/2016.**

U-4715B**ITS-121****Buncombe County**

rigid galvanized steel sweeping elbow without the use of additional fittings, hardware or adhesives. Connect the opposite, non-threaded end of the adapter to the underground PVC conduit using a slip fit, glued connection.

The Plans call for installation of a new 2" riser with heat-shrink tubing at some base-mounted cabinet locations in or near downtown Asheville where the existing cabinet foundation will be retained but there is no existing spare conduit stub-out to receive a new riser for fiber-optic cable and it is not feasible to modify the foundation to add a new conduit entrance. At such locations, install the new riser into the side of the cabinet base extender or base adapter in lieu of the existing cabinet foundation. Do not use this method except where designated in the Plans and without the prior approval of the Engineer. Use of this method is prohibited where the Plans call for installing a new conduit entrance into an existing foundation, where there is an existing spare conduit stub-out from the foundation to which the riser can be attached and where the Plans call for construction of a new cabinet foundation. Core drill a hole through the base adapter/extender on the side adjacent to the new riser and no larger in diameter than the inside diameter of the 2" RGS riser to be attached. Use a standard 90-degree elbow for 2-inch RGS conduit at the bottom of the riser or form a 90-degree bend with a minimum radius of 7 inches in the bottom of the riser, then connect the riser to the hole in the base extender/adapter using threaded rigid conduit nipple on the interior of the base extender/adapter and a sealing conduit locknut on the exterior. Provide rigid galvanized steel or malleable iron conduit nipples and sealing locknuts. To ensure a watertight seal of the at the entry point in the cabinet base adapter/extender, use sealing locknuts that are UL-listed as raintight and UL-listed as liquidtight and that are designed for use with NEMA Type 3R and Type 4 enclosures.

Bond all new risers, a minimum of 10 feet above grade, to the pole ground using a #6 AWG minimum solid bare copper wire and an approve pipe clamp, a split-bolt connector or parallel groove clamp. On pole-mounted cabinets where the risers are connected to the cabinet, bond risers in the cabinet using ground bushings with a #6 AWG minimum solid bare copper wire to cabinet ground bus.

If a pole ground exists on a joint-use pole, bond new riser to the existing pole ground using #6 AWG minimum solid bare copper wire terminated with split-bolt connectors or parallel groove clamp.

If the existing pole does not have a grounding system, install new grounding system in accordance with the "Wood Poles" section of the *Standard Specifications*, except use hot-dipped galvanized 1.5" wire staples to secure ground wire to pole, spacing the staples along the pole as follows:

- 4 inches apart from ground level to 8 feet above ground level;
- 24 inches apart from 8 feet above ground level to point adjacent to uppermost span.

13.4. MEASUREMENT AND PAYMENT

" Riser with _____ will be measured and paid as the actual number of risers of each type and size furnished, installed, and accepted.

No measurement will be made of weatherheads, heat shrink tubing, temporary pipe caps, bushings, conduit outlet bodies such as condulets, elbows, conduit fittings, PVC female adapters, conduit nipples, conduit locknuts and sealing locknuts, pole attachment fittings, weep hole-

◆ **Revision No. 1, April 10, 2017 – This document supersedes version originally issued and sealed by J. Todd Brooks, NCPE No. 017586 on 12/28/2016.**

U-4715B**ITS-122****Buncombe County**

drilling and zinc-rich touch-up paint as these will be considered incidental to furnishing and installing risers. No measurement will be made of temporarily removing from and subsequently reinstalling existing cables in a riser and cutting off and removing the above-ground portion of an existing PVC riser to replace it with a new rigid metal riser as such work will be considered incidental to installing the new riser. No measurement will be made of core-drilling a conduit entrance through a cabinet base adapter or cabinet base extender for attachment of a riser where required as such work will be considered incidental to furnishing and installing the new riser.

Ground rods (grounding electrodes) installed as part of pole grounding systems will be measured and paid for in accordance with the “Electrical Service” section of these Project Special Provisions. No measurement will be made for furnishing and installing #6 AWG solid bare copper wire, messenger bonding clamps, hot-dipped galvanized wire staples, and exothermic welding as part of pole grounding systems as such work will be considered incidental to furnishing and installing the wood poles, messenger cable, risers and grounding electrodes.

No measurement will be made for horizontal sections of underground conduit that connect the riser to stub-outs in an adjacent cabinet foundation or to an adjacent junction box and that measure 10 feet or less in horizontal length from the center of the riser to the center of junction box or from the center of the riser to the center of the vertical sweep through the controller cabinet foundation. Such conduit will be considered incidental to furnishing and installing the riser assembly.

No measurement will be made for vertical conduit segments (i.e., short risers) extending from an entrance in the bottom of a pole-mounted cabinet to ground level below the cabinet to tie directly onto an underground conduit as such conduits will be considered incidental to furnishing and installing the pole-mounted cabinet.

No measurement will be made of risers with weatherheads furnished and installed as part of new electrical services as they will be considered incidental to furnishing and installing new electrical services (see “Electrical Service” section of these Project Special Provisions).

No measurement will be made of painting or powder coating risers mounted on black and dark green metal poles in downtown Asheville and in Biltmore Village as such work will be considered incidental to furnishing and installing the risers.

Heat shrink tubing retrofit kit will be measured and paid for as the actual number of heat shrink tubing retrofit kits furnished, installed, and accepted.

No measurement will be made of removing existing weatherheads, sealing bushings, heat shrink tubing and riser caps from existing risers as such removals will be considered incidental to furnishing and installing heat shrink tubing retrofit kits.

Payment will be made under:

| Pay Item | Pay Unit |
|----------------------------------|-----------------|
| 1/2" Riser with Weatherhead | Each |
| 1" Riser with Weatherhead | Each |
| 2" Riser with Weatherhead | Each |
| 1" Riser with Heat Shrink Tubing | Each |

◆ **Revision No. 1, April 10, 2017 – This document supersedes version originally issued and sealed by J. Todd Brooks, NCPE No. 017586 on 12/28/2016.**

U-4715B

ITS-123

Buncombe County

Pay Item

Pay Unit

1.25" Riser with Heat Shrink Tubing

Each

2" Riser with Heat Shrink Tubing

Each

Heat Shrink Tubing Retrofit Kit

Each

◆ **Revision No. 1, April 10, 2017 – This document supersedes version originally issued and sealed by J. Todd Brooks, NCPE No. 017586 on 12/28/2016.**

14. INDUCTIVE DETECTION LOOPS

14.1. DESCRIPTION

Furnish and install inductive detection loops with loop slot sealant, loop wire, conduit with fittings, and all necessary hardware.

14.2. MATERIALS

Furnish material, equipment, and hardware furnished under this section that is pre-approved on the ITS and Signals QPL.

A. Loop Sealant

Provide the Engineer with a Type 3 material certifications and material safety data sheets (MSDS) for the sealant in accordance with Article 106-3 of the *Standard Specifications*.

Provide loop slot sealant that completely encapsulates loop wire when installed according to manufacturer's instructions. Provide loop sealant that does not generate temperatures greater than 220° F. Ensure sealant bonds with asphalt and concrete pavement saw slots so sealant and encapsulated loop wire do not come out of slot. Ensure sealant is self-leveling, but with sufficient viscosity to prevent exit from saw slot when installed along a 10% grade.

Provide sealant that protects loop wire by preventing the entrance of dirt, water, rocks, sticks, and other debris into saw slot, and is resistant to traffic, water, gasoline, chemical and chemical fumes, mild alkalis, oils, and mild acids. Ensure sealant will not be affected by water and sealant does not chemically interact with pavement and loop wire insulation.

Ensure loop sealant has sufficient flexibility to permit expected pavement expansion and contraction due to weather and to permit pavement movement due to traffic without cracking for a temperature range of -40 to 160° F.

Provide sealant with a usable life of at least ten minutes once mixed, when the ambient temperature is 75° F. Ensure sealant dries to tack-free state in less than 2 hours, and does not flow within or out of saw slot after exposed surface has become tack free. Tack free time will be determined by testing with a cotton ball until no sealant adheres to cotton ball and no cotton adheres to sealant.

Ensure two-part sealant cures within 48 hours to attain 95% of published properties for the cured material.

Ensure one part sealant cures within 30 days to attain 95% of published properties for the cured material.

B. Loop Wire

Provide loop wire composed of 19-strand conductor insulated by a cross-linked polyethylene compound. Ensure insulated conductors are completely encased in tubes of low density polyethylene compound. Print manufacturer's name, manufacture year, and any applicable part number on encasing tube at intervals of 2 feet or less.

Provide #14 AWG copper conductors fabricated from 19 strands that comply with ASTM B3 before insulating. Ensure stranded conductors use either concentric or bunch stranding, and

◆ **Revision No. 1, April 10, 2017 – This document supersedes version originally issued and sealed by J. Todd Brooks, NCPE No. 017586 on 12/28/2016.**

U-4715B**ITS-125****Buncombe County**

comply with circular mil area and physical requirements of ASTM B8 or ASTM B174 for bunch stranding.

Provide insulating compound that is cross-linked thermosetting black polyethylene in accordance with ASTM D 2655. Ensure insulation is applied concentrically about conductor. Provide insulation thickness not less than 0.026" at any point and minimum average thickness of 0.030" as measured by UL Standard 62.

Ensure insulation of finished conductor will withstand application of a 60 Hertz or 3,000 Hertz, 7,500 volt (RMS) essentially sinusoidal spark test potential as specified in UL Standard 83.

Provide insulated conductors that are factory-installed in protective encasing tube that complies with the following:

- Encasing tube fabricated of polyethylene compound conforming to ASTM D1248 for Type I, Class C, Grade E5.
- Minimum inside diameter of 0.150"
- Wall thickness of 0.040" ± 0.010"
- Outside diameter of 0.240" ± 0.010" Conduit

C. Conduit

Comply with the "Underground Conduit" section of these Project Special Provisions for PVC conduit.

14.3. CONSTRUCTION METHODS

All work performed in this section shall be done in the presence of the Engineer.

Notify Engineer one week before installing inductive detection loops.

Coordinate sawcutting and loop placement with pavement markings. For new construction or for resurfacing, install inductive detection loops before placing final layer of surface course. On unmarked pavement, pre-mark locations of stop lines and lane lines before locating inductive detection loops.

Before sawcutting, pre-mark inductive detection loop locations and receive approval. Sawcut pavement at approved pre-marked locations. Do not allow vehicles to travel over unsealed loop slots.

Install conduit with bushings from edge of pavement to junction box. Do not sawcut through curb. Do not sawcut or drill holes for conduit or wires through granite curb. See additional requirements for work in historic districts in Section 1 of these Project Special Provisions.

Remove all loose material and wash saw slots with a high-pressure method using an air and water mixture. Dry saw slots with compressed air. Clear saw slots of jagged edges and protrusions. Seat loop conductor at bottom of saw slot without damaging loop wire.

Before sealing loop conductors, test that impedance from the loop wire to ground is at least 100 megohms. For each location with inductive loops, submit a completed Inductive Detection Loop & Grounding Test Results form and place copy in controller cabinet. Ensure all loops are included on form. The form is located on the Department's website at <https://connect.ncdot.gov/resources/safety/Pages/ITS-and-Signals.aspx> .

◆ **Revision No. 1, April 10, 2017 – This document supersedes version originally issued and sealed by J. Todd Brooks, NCPE No. 017586 on 12/28/2016.**

U-4715B

ITS-126

Buncombe County

Embed loop conductors in saw slot with loop sealant. Seal saw slot and dispose of excess sealant in an environmentally safe manner.

Between where loop conductor pairs leave the saw cut in pavement and enter a junction box, twist loop conductor pairs a minimum of 5 turns per foot. Permanently label each twisted pair in the junction box with nylon cable tie using indelible ink. Indicate loop number and loop polarity on the tie.

14.4. MEASUREMENT AND PAYMENT

Inductive loop sawcut will be measured and paid as the actual linear feet of inductive loop sawcut furnished, installed, and accepted.

No measurement will be made of loop slot sealant, loop wire, conduit, and conduit fittings as these will be considered incidental to furnishing and installing inductive detection loops.

Payment will be made under:

| Pay Item | Pay Unit |
|-----------------------|-----------------|
| Inductive Loop Sawcut | Linear Foot |

U-4715B

ITS-127

Buncombe County

15. LEAD-IN CABLE

15.1. DESCRIPTION

Furnish and install lead-in cable with all necessary hardware to be used in conjunction with, but not limited to, inductive detection loops, pedestrian pushbutton assemblies or railroad circuitry.

15.2. MATERIALS

Furnish material, equipment, and hardware furnished under this section that is pre-approved on the ITS and Signals QPL.

Furnish lead-in cable with two conductors of #14 AWG fabricated from stranded tinned copper that complies with IMSA Specification 50-2 except as follows:

- Ensure conductor is twisted with a maximum lay of 2.0 inches, resulting in a minimum of 6 turns per foot.
- Provide a ripcord to allow cable jacket to be opened without using a cutter.

Provide length markings in a contrasting color showing sequential feet and within 1% of actual cable length. Ensure character height of the markings is approximately 0.10 inch.

Refer to the “Pole Line Hardware” subsection of the “Messenger Cable” section of these Project Special Provisions.

15.3. CONSTRUCTION METHODS

For underground runs, install lead-in cable in 2-inch non-metallic conduit. For aerial installation, wrap lead-in cable to messenger cable with at least four turns of wrapping tape spaced at intervals less than 15 inches or lash lead-in cable to messenger cable with one 360° spiral of lashing wire per 12 inches.

Where railroad preemption is required, install lead-in cable from signal controller cabinet to railroad company furnished and installed lockable junction box.

Except where the plans call for splicing and extending existing lead-in cable conductors inside a new controller cabinet or for using a terminal splice box to splice and extend existing lead-in cable to a new cabinet location, splicing of lead-in cable will be allowed only for runs in excess of 750 feet. Splice lead-in cable in terminal splice boxes, junction boxes, condulets on poles or controller cabinets.

Test each complete loop system from the controller cabinet by using a megger to verify that impedance from the loop system to the ground is at least 50 megohms. After successful completion of megger test, test loop system resistance using an electronic ohmmeter to verify loop system resistance is less than 0.00885 ohms per foot.

Where the Plans call for using existing upstream detection loops on an approach to a signalized intersection for both local intersection and system detection (i.e., shared local/system loops), field verify that each such loop is wired to a separate lead-in cable all the way back to the controller cabinet. If proposed shared loops are wired to a common lead-in cable, install new lead-in cables necessary to rewire each loop to a separate, unique lead-in cable, then splice each loop to its respective lead-in cable, as approved by the Engineer. Perform said field

◆ **Revision No. 1, April 10, 2017 – This document supersedes version originally issued and sealed by J. Todd Brooks, NCPE No. 017586 on 12/28/2016.**

U-4715B**ITS-128****Buncombe County**

investigations of proposed shared loops, and, as necessary, install new lead-in cables and resplice loop wires to lead-in cables to separate share system/local loops onto separate lead-in cables, regardless of whether or not Plans specifically call for installation of new lead-in cable at a given intersection. Notify the Engineer of findings from field investigations and obtain Engineer's approval prior to installing any new lead-in cables and rewiring proposed share local/system loops.

15.4. MEASUREMENT AND PAYMENT

Lead-in cable (____) will be measured and paid as the actual linear feet of lead-in cable furnished, installed, and accepted. Measurement will be made by calculating the difference in length markings located on outer jacket from start of run to end of run for each run. Terminate all cables before determining length of cable run.

If markings are not visible, measurement will be point to point with no allowance for sag. Twenty-five feet will be allowed for vertical segments up or down poles.

Payment will be made under:

| Pay Item | Pay Unit |
|----------------------|-----------------|
| Lead-in Cable (14-2) | Linear Foot |

◆ **Revision No. 1, April 10, 2017 – This document supersedes version originally issued and sealed by J. Todd Brooks, NCPE No. 017586 on 12/28/2016.**

16. MICROWAVE VEHICLE DETECTION SYSTEM - MULTIPLE DETECTION ZONES

16.1. DESCRIPTION

Design, furnish and install a microwave vehicle detection system with the manufacturer recommended cables and hardware in accordance to the Plans and these Project Special Provisions. Ensure the detection system provides multiple detection zones.

16.2. MATERIALS

Provide design drawings showing design details and microwave sensor locations for review and acceptance before installation. Provide mounting height and location requirements for microwave sensor units on the design based on a site survey. Design microwave vehicle detection system with all necessary hardware. Indicate all necessary poles, spans, mast arms, luminaire arms, cables, microwave sensor mounting assemblies and hardware to achieve the required detection zones where Department owned poles are not adequate to locate the microwave sensor units. Do not design for the installation of poles in medians.

Obtain the Engineer's approval before furnishing microwave vehicle detection system. The contractor is responsible for the final design of microwave vehicle detection system. Review and acceptance of the designs by the Department does not relieve the contractor from the responsibility to provide fully functional systems and to ensure that the required detection zones can be provided. With the exception of contractor-furnished poles, mast arms, and luminaire arms, furnish material, equipment, and hardware under this section that is pre-approved on the ITS and Signals QPL. Submit and obtain Engineer's approval of shop drawings for any poles, mast arms, and luminaire arms provided by the contractor prior to ordering from manufacturer.

Provide a detector for either side-fire or forward-fire configuration. Ensure the detector will detect vehicles in sunny, cloudy, rainy, snowy, and foggy weather conditions. Ensure the detector can operate from the voltage supplied by a NEMA TS-1/TS-2 or Type 332 or 336 traffic signal cabinet. Ensure the detector can provide detection calls to the traffic signal controller within a NEMA TS-1/TS-2 or Type 332 or 336 cabinet. Ensure the detection system provides a constant call in the event of a component failure or loss of power. Ensure the detector has an operating temperature range of -30 to 165 degrees F and operates within the frequency range of 10 to 25 GHz. Ensure the detector is provided with a water-tight housing offering NEMA 4X protection and operates properly in up to 95% relative humidity, non-condensing.

Provide each detector unit to allow the placement of at least 8 detection zones with a minimum of 8 detection channel outputs. When the microwave vehicle detection system requires an integrated card rack interface(s), provide only enough interface cards to implement the vehicle detection shown on the signal plans. Provide a means acceptable to the Engineer to configure traffic lanes and detection zones. Provide each channel output with a programmable means to delay the output call upon activation of a detection zone that is adjustable in one second increments (maximum) over the range of 0 to 25 seconds. Provide each channel output with a programmable means to extend the output call that is adjustable in one second increments (maximum) over the range of 0 to 25 seconds. Ensure both delay and extend timing can be set for the same channel output.

◆ **Revision No. 1, April 10, 2017 – This document supersedes version originally issued and sealed by J. Todd Brooks, NCPE No. 017586 on 12/28/2016.**

U-4715B**ITS-130****Buncombe County**

For advance detection system, ensure the detector senses vehicles in motion at a range of 50 to 400 feet from the detector unit for forward-fire configuration and a range of 50 to 200 feet from the detector unit for side-fire configuration with an accuracy of 95% for both configurations. Ensure the advance detection system provides each channel output call of at least 100 ms in duration.

For stop bar presence detection system, ensure the detector outputs a constant call while a vehicle is in the detection zone and removes the call after all vehicles exit the detection zone. Ensure the presence detector unit can cover a detection zone as shown on the plans and has an effective range of 10 to 120 feet from the detector unit.

For units without an integrated card rack interface, provide Form C output relay contacts rated a minimum of 3A, 24VDC.

If a laptop is used to adjust detector settings, ensure that software is licensed for use by the Department and by any other agency responsible for maintaining or operating the microwave detection system. Provide the Department with a license to duplicate and distribute the software as necessary for design and maintenance support.

After initial detector configuration and installation, ensure routine adjustments or calibration are not needed to maintain acceptable performance.

16.3. CONSTRUCTION METHODS

Install the microwave vehicle detection system in accordance with the manufacturer's recommendations.

Monitor and maintain each detector unit during construction to ensure microwave vehicle detection system is functioning properly and aimed for the detection zone shown in the plans. Refer to Subarticle 1700-3 (D) Maintenance and Repair of Materials of the *Standard Specifications* for failure to maintain the microwave detection system.

16.4. MEASUREMENT AND PAYMENT

MW Veh Det Sys – Multi Zone will be measured and paid as the actual number of microwave vehicle detection systems – multiple zones furnished, installed, and accepted.

No measurement will be made of cables or hardware, as these will be considered incidental to furnishing and installing microwave vehicle detection systems – multiple zones.

Payment will be made under:

| Pay Item | Pay Unit |
|-----------------------------|-----------------|
| MW Veh Det Sys – Multi Zone | Each |

◆ **Revision No. 1, April 10, 2017 – This document supersedes version originally issued and sealed by J. Todd Brooks, NCPE No. 017586 on 12/28/2016.**

17. FIBER-OPTIC CABLE

17.1. DESCRIPTION

Furnish and install single mode fiber-optic (SMFO) communications cable and drop cable assemblies, fiber-optic cable storage guides (snow shoes), communications cable identification markers, lashing wire, and all necessary hardware.

17.2. MATERIALS

A. General

Refer to the “Pole Line Hardware” subsection of the “Messenger Cable” section of these Project Special Provisions for lashing wire, wrapping tape and hardware used for installation of aerial fiber-optic cable.

B. SMFO Communications Cable

For all cables except for cables specified to plenum-rated, furnish single-mode fiber-optic communications cable that is pre-approved on the Department’s QPL. For plenum-rated cables, provide single-mode fiber-optic cables that comply with the “Plenum-rated SMFO Communications Cable” subsection below. Furnish fiber-optic cable that is all-dielectric and gel-free.

Furnish single-mode fiber-optic cable manufactured into a loose buffer tube design installed around a central strength member where the cable complies with RUS CFR 1755.900 and ICEA 640 requirements. Ensure the manufacturer is ISO 9001 and TL9000 registered and that the manufacturer’s cable is RUS listed. The operating temperature range of the cable shall be -40°F to +158°F.

Furnish individual fibers manufactured from silica and dopant materials with each fiber having a color coated finish that is compatible with local injection detection (LID) devices. Distinguish each fiber from others by color coding that meets EIA/TIA-598. Furnish single mode fiber that does not exceed attenuation ratings of 0.25 dB/km at 1550 nm and 0.35 dB/km at 1310 nm and complies with ITU G.652D and IEC 60793-2-50 Type B.1.3 industry standards for low water peak, single mode fiber. Provide fibers that are useable and with a surface, sufficiently free of imperfections and inclusions to meet optical, mechanical and environmental requirements.

Ensure the core central strength member is a dielectric glass reinforced rod and that the completed cable assembly has a maximum pulling rating of 600 lbf during installation (short term) and 180 lbf long term installed.

Construct buffer tubes (nominal size of 2.5 mm) manufactured from a polypropylene copolymer material to provide good kink resistance and allows the buffer tube to maintain flexibility in cold temperature over the expected lifetime of the cable. Except for drop cables, provide exactly 12 fibers per buffer tube in all cables regardless of the total number of fibers the cables contain. Except for drop cables which may be provided with either 6 fibers or 12 fibers per buffer tube, do not provide cables with any other fiber count per buffer tube. Ensure that that all buffer tubes are filled with a water-blocking gel or water swellable material. Construct the cable such that the buffer tubes are stranded around the central strength member in a reverse

◆ **Revision No. 1, April 10, 2017 – This document supersedes version originally issued and sealed by J. Todd Brooks, NCPE No. 017586 on 12/28/2016.**

U-4715B**ITS-132****Buncombe County**

oscillating arrangement to allow for mid-span entry. Distinguish each buffer tube from others by color coding that meets EIA/TIA-598. Use filler tubes to maintain a circular cross-section of the cable. Ensure the filler tubes are the same nominal size as the buffer tubes. Apply binders (water swellable yarn, aramid fiber, etc.) with sufficient tension to secure buffer tubes and filler tubes to the central member without crushing the buffer tubes. Ensure that binding material is non-hygroscopic, non-wicking and dielectric with low shrinkage. Ensure the binders are of a high tensile strength that is helically stranded evenly around cable core.

Ensure the cable core is protected from the ingress of moisture by a water swellable material or that is filled with a water blocking compound that is non-conductive. Ensure the water swellable material (when activated) or the water blocking compound is free from dirt and foreign matter and is removable with conventional nontoxic solvents. Furnish at least one ripcord to aid in the process of removing the outer jacket. Furnish the outer jacket constructed of a medium-density polyethylene material to provide reduced friction and enhanced durability. Ensure the polyethylene material contains carbon black to provide UV protection and does not promote the growth of fungus. Ensure the cable jacket is free of slits, holes or blisters and the nominal outer jacket thickness is > 0.050 ".

Ensure the completed cable assembly contains identifications markings printed along the outside cover of the jacket every 2 feet. Ensure the character height of the markings is approximately 0.10". Provide length markings in sequential feet and within one percent of actual cable length.

Mark each cable with the following:

- (1) Sequential length marks in feet as specified
- (2) The name of the manufacturer
- (3) "OPTICAL CABLE"
- (4) Month/year of manufacture
- (5) Number(s) of and type(s) of fibers
- (6) Cable ID Number for product traceability

1. Plenum-Rated SMFO Communications Cable

Where called for in the Plans, provide plenum-rated SMFO communications cable. Provide optical fiber nonconductive plenum (OFNP) SMFO cable that complies with the following:

- UL[®] fire safety test Plenum/910
- NEC[®] Article 770
- Telcordia GR-409

Provide a cable with a flame retardant outer jacket or a flame retardant tape inside the outer jacket or. Provide a loose-tube, gel-free cable that is designed for both indoor and outdoor installation. The plenum-rated cable shall meet all other material and operating characteristics of SMFO communications cable called for in these Project Special Provisions, with the exception of the requirement for a maximum 0.35 dB/km loss at 1310 nm. Plenum-rated cables shall have a maximum 0.65 dB/km loss at 1310 nm.

◆ **Revision No. 1, April 10, 2017 – This document supersedes version originally issued and sealed by J. Todd Brooks, NCPE No. 017586 on 12/28/2016.**

U-4715B

ITS-133

Buncombe County

C. Drop Cable

Provide drop cable meeting the material requirements list in “SMFO Communications Cable” subsection above with the exceptions herein to provide communications links between splice enclosures and the Ethernet edge switches through interconnect centers mounted in controller cabinets and in CCTV cabinets. Furnish drop cables containing a minimum of twelve individual fibers. Ensure drop cable has the same operating characteristics as the SMFO cable it is to be coupled with.

On one end of the cable, furnish LC connectors for termination of all drop cable fibers on connector panel mounted inside an equipment cabinet. Provide either factory preassembled drop cables with SMFO pigtailed and LC connectors already attached or field install the pigtailed and connectors. For field installed connectors, provide cabinet-mounted interconnect centers that are pre-equipped with factory-preassembled connector panels, SMFO pigtailed with LC connectors and splice trays; then fusion splice all drop cable fibers to the SMFO pigtailed.

Ensure attenuation loss for complete drop cable does not exceed a mean value of 1.5 dB.

D. Communications Cable Identification Markers

Furnish communications cable identification markers that are resistant to fading when exposed to UV sources and changes in weather. Use markers designed to coil around fiber-optic cable that do not slide or move along the surface of the cable once installed. Ensure exposure to UV light and weather does not affect the markers natural coiling effect or deteriorate performance. Provide communications cable wraps that permit writing with an indelible marking pen.

Furnish cable identification markers with the following text for signal system communications cables:

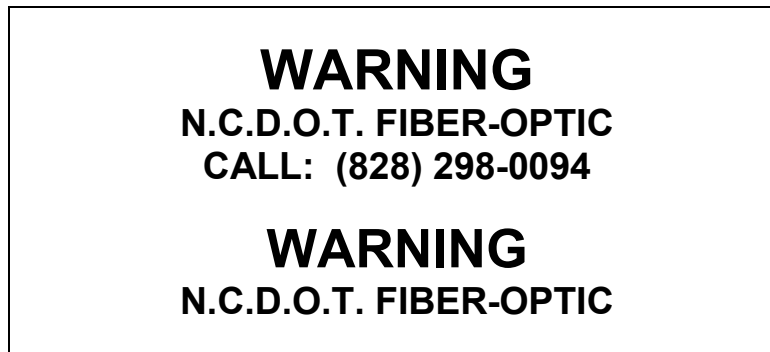

Overall Marker Dimensions: 7(l) x 4 (w) inches

Lettering Height: 3/8 inch for "WARNING"; 1/4" for all other lettering

Colors: Black text on yellow background

Submit a sample of proposed communications cable identification marker to the Engineer for approval before installation.

◆ **Revision No. 1, April 10, 2017 – This document supersedes version originally issued and sealed by J. Todd Brooks, NCPE No. 017586 on 12/28/2016.**

E. Fiber-Optic Cable Storage Guides

Furnish fiber-optic cable storage guides (snowshoes) that are pre-approved on the ITS and Signals QPL.

Furnish fiber-optic storage guides (snowshoes) that are non-conductive and resistant to fading when exposed to UV sources and changes in weather. Ensure snowshoes have a captive design such that fiber-optic cable will be supported when installed in the rack and the minimum bending radius will not be violated. Provide stainless steel attachment hardware for securing snowshoes to messenger cable and black UV resistant tie-wraps for securing fiber-optic cable to snowshoe. Ensure snowshoes are stackable so that multiple cable configurations are possible.

F. Aerial Cable Protectors

Furnish aerial cable protectors designed to protect aerial fiber-optic communications cable from damage caused by tree limb abrasion. Provide cable protectors that are designed to fit over the cable as a wrap-around protective sleeve, that have a round shape and are fabricated with cable tie slots spaced approximately 12 inches apart along the entire length. Size the cable protectors to fit properly over cable(s) lashed to messenger cable in accordance with the manufacturer's guidelines. Provide cable protectors that are constructed of rugged, durable dielectric material such as high density PVC that is black in color, formulated for outdoor use and has special additives to prevent degradation from ultraviolet light. Provide aerial cable protectors that are designed for a service life of at least 10 years.

17.3. CONSTRUCTION METHODS

A. General

Provide cable manufacturer's attenuation and Optical Time Domain Reflectometer (OTDR) testing data for each reel of cable.

Install SMFO communications cable, snow shoes, communications cable identification markers, lashing wire, and all necessary hardware.

Comply with manufacturer's recommendations. Install communications cable on signal poles, utility poles, messenger cable, and in conduits as required to bring the fiber-optic cable into and, if necessary, out of each splice enclosure.

Take all precautions necessary to ensure cable is not damaged during storage, handling, and installation. Do not violate minimum bending radius of 20 times the cable diameter or manufacturer's recommendation, whichever is greater. Do not step on cable nor run over cable with vehicles or equipment. Do not pull cable over or around obstructions, or along the ground.

Determine lengths of cable necessary to reach from termination-point to termination-point. Install cable in continuous lengths between approved splicing facilities. Additionally, provide a sufficient amount of slack cable to allow for an additional 20 feet of cable to be present after removal of outer sheath for termination. Store the 20 feet of spare cable inside the cabinet. Measure slack cable by extending cable straight out of cabinet door. No splicing is permitted at any field cabinets other than splicing drop cable fibers to SMFO pigtails in cabinet-mounted interconnect centers inside traffic signal controller cabinets and CCTV cabinets.

Keep cable ends sealed at all times during installation to prevent effectively the ingress of moisture. Use approved heat shrink cable end cap. Do not use tape to seal cable ends.

◆ **Revision No. 1, April 10, 2017 – This document supersedes version originally issued and sealed by J. Todd Brooks, NCPE No. 017586 on 12/28/2016.**

U-4715B**ITS-135****Buncombe County**

Before installing cable, provide three copies of cable manufacturer's recommended and maximum pulling tension. Do not exceed manufacturer's recommended pulling tension. Use pulling grips containing a breakaway rotating swivel. Coil cable in a figure-8 configuration whenever cable is unreeled for subsequent pulling.

Install fiber-optic cable in separate risers with heat shrink tubing (1.25-inch or 2-inch as shown on the Plans) or separate conduits. Do not share risers or conduits containing fiber-optic cable with other non-fiber-optic cable unless the Plans specify otherwise or the Engineer directs or approves otherwise.

Within the City Hall building, transition from outdoor cable to plenum-rated cable in the telecommunications room in the basement near the building entry point as shown in the Plans. Use plenum-rated fiber-optic cable for all indoor runs of fiber-optic cable inside City Hall. Through splice all fiber strands in each cable.

Seal all conduits containing fiber-optic communications cable in junction boxes and cabinet bases with duct and conduit sealer. Comply with the requirements for duct and conduit sealer in the "Underground Conduit" section of these Project Special Provisions.

B. Aerial Installation

Install one communications cable identification marker on the signal system communications cable within 36 inches of the attachment point on each pole and at locations where more than one cable originates or terminates. At splice enclosures, install a communications cable marker on one of the cables where it enters or exits the splice enclosure and ensure that the marker is installed so that it visible (but not necessarily readable) from the ground below. At fiber-optic cable storage guides (i.e., snow shoes), install a communications cable marker at each end, 6 inches or less from the inner edge of each snow shoe, to identify the cable being stored.

Double lash fiber-optic cable to messenger cable with one 360° spiral per foot.

Machine lashing of any cable is not permitted along any messenger cable span to which a traffic signal or overhead sign is or will be attached. Either reuse existing 0.05" x 0.30" aluminum wrapping tape or furnish and install new aluminum wrapping tape.

Use pole attachment hardware and roller guides with safety clips to install aerial run cable.

Use a breakaway swivel so as not to exceed 80% of the maximum allowable pulling tension specified by the cable's manufacturer if cable is pulled by mechanical means. Do not allow cable to contact the ground or other obstructions between poles during installation.

Use a cable suspension clamp when attaching cable tangent to a pole. Select and place cable blocks and corner blocks so as not to exceed the cable's minimum bending radius. Do not pull cable across J-hooks.

Store 100 feet of each fiber-optic cable on all cable runs that are continuous without splices as shown in the Plans. Obtain approval for spare cable storage locations. Store spare fiber-optic cable on fiber-optic cable storage guides (snow shoes) that are separate from any storage guides being used to store any other communications cables.

Locate spare cable storage in the middle of spans between termination points. Do not store spare fiber-optic cable over the roadway or driveways.

◆ **Revision No. 1, April 10, 2017 – This document supersedes version originally issued and sealed by J. Todd Brooks, NCPE No. 017586 on 12/28/2016.**

U-4715B

ITS-136

Buncombe County

C. Underground Installation

Install fiber-optic cable underground in conduit using cable pulling lubricants recommended by the fiber-optic cable manufacturer. Where more than one fiber-optic cable is being installed in a multiple conduit underground run, ensure that at least one conduit remains empty for future use by installing more than one cable in a conduit as needed, unless directed otherwise by the Engineer.

Obtain approval of cable pulling lubricant and method of pulling before installing underground fiber-optic cable.

Use a breakaway swivel so as not to exceed 80% of the maximum allowable pulling tension specified by the cable's manufacturer if cable is pulled by mechanical means.

Keep tension on cable reel and pulling line at start of each pull. Do not release tension if pulling operation is halted. Restart pulling operation by gradually increasing tension until cable is in motion.

For pulling cable through junction boxes, feed cable by manually rotating the reel. Do not pull cable through intermediate junction boxes, handholds, or openings in conduit unless otherwise approved.

Inside all junction boxes, install communications cable identification markers on each communications cable entering the junction box.

In a junction box where no splice enclosure is required, store 50 feet of each fiber-optic cable on all cable runs as shown in the Plans.

In a junction box where a splice enclosure is required but not immediately installed, store 50 feet of fiber-optic cable intended for the splice as shown in the Plans.

If a blockage is encountered when attempting to install a communications cable inside an existing conduit in accordance with the Plans, use compressed air, water jetting, rod and mandrel or other Engineer-approved method to clear the obstruction or blockage in the existing underground conduit. Once obstruction/blockage has been substantially cleared, draw a mandrel through the conduit followed by a swab to clean out any remaining materials which may cause cable abrasions. Use a mandrel constructed of aluminum or stainless steel that is at least 6 inches in length and has an outer diameter that is approximately 1/2 inch less than the inside diameter of the conduit being cleared.

Subject to the Engineer's approval, the existing communications cable being removed may be used as a pull line to install the new fiber-optic communications cable and accompanying tracer wire in its place in existing underground conduits.

D. Indoor Installation

Install the fiber-optic cable in risers and conduits between the building entrance and the termination point inside the building using cable pulling lubricants recommended by the fiber-optic cable manufacturer. Obtain approval of cable pulling lubricant and method of pulling before installing the fiber-optic cable.

Use a breakaway swivel so as not to exceed 80% of the maximum allowable pulling tension specified by the cable's manufacturer if cable is pulled by mechanical means. Keep tension on

◆ **Revision No. 1, April 10, 2017 – This document supersedes version originally issued and sealed by J. Todd Brooks, NCPE No. 017586 on 12/28/2016.**

cable reel and pulling line at start of each pull. Do not release tension if pulling operation is halted. Restart pulling operation by gradually increasing tension until cable is in motion.

For pulling cable through junction boxes and cabinets, feed cable by manually rotating the reel. Do not pull cable through cabinets, junction boxes, handholds, or openings in conduit unless otherwise approved. Inside all junction boxes and cabinets, install communications cable identification markers on each communications cable entering the junction box.

Store 30 feet of each fiber-optic cable inside the enclosed communications racks inside the TMC after terminating the cables in the rack-mounted splice centers housed therein.

Transition the fiber-optic cable from outdoor cable to indoor, plenum-rated cable in the basement communications closet after entry into the City Hall building by fusion splicing the cables inside a wall-mounted splice center as shown in the Plans. Install the plenum-rated fiber-optic cable in existing risers and conduits between the telecommunications closet on the basement floor to the Transportation Department on the Mezzanine Level using cable pulling lubricants recommended by the fiber-optic cable manufacturer. Obtain approval of cable pulling lubricant and method of pulling before installing the fiber-optic cable. Coil and store at least 20 feet of slack plenum-rated cable above the Mezzanine Level ceiling and an additional 50 feet of slack plenum-rated cable on the overhead cable ladder rack inside the telephone communications closet in the basement as shown in the Plans.

E. Installation of Drop Cable

Verify the length of drop cable needed, including slack, to reach from termination point to termination point.

At aerial splice enclosures, install the aerial splice enclosure and corresponding cable storage guide 50 feet apart and store between the splice enclosure and corresponding cable storage guide 50 feet of slack cable for each cable entering and exiting the splice enclosure.

At below ground splice enclosures, coil 50 feet of slack cable for each cable entering and exiting the splice enclosure in the manhole or junction box where enclosure is located. Coil and store any drop cable in excess of what is needed for storage in the manhole or junction box in the base of the equipment cabinet. Where fiber-optic cables are installed but not immediately spliced, store 50 feet of drop cable and 50 feet of fiber-optic trunk cable inside the manhole or junction box to facilitate subsequent splicing in the splice enclosure. Cap and seal ends of cables that have yet to be spliced or terminated with a waterproof heat-shrink cap/seal as approved by the Engineer.

At the equipment cabinet end of drop cable, terminate the first six fibers (i.e., fibers 1-6) by fusion splicing them to factory-assembled SMFO pigtailed with LC connectors and connecting the pigtailed to the connector panel in the rack-mounted interconnect center. Label all connectors, pigtailed and the connector panel. At the aerial or underground splice location, cap off all unused fibers and label to correspond with the connector panel. After termination, coil and store in the base of the equipment cabinet 20 feet of drop cable plus any additional drop cable in excess of what is needed for overhead storage.

Where the Plans call for a fiber-optic drop cable to be installed in an existing riser, remove all existing cables from the riser and remove the existing weatherhead, sealing bushing or heat shrink tubing. Install the new fiber-optic drop cable in the existing riser and install new heat shrink tubing at the top of the existing riser using a heat shrink tubing retrofit kit. If the riser

◆ **Revision No. 1, April 10, 2017 – This document supersedes version originally issued and sealed by J. Todd Brooks, NCPE No. 017586 on 12/28/2016.**

U-4715B

ITS-138

Buncombe County

contains existing fiber-optic communications cable, carefully remove the fiber-optic cable from the riser so as not to violate its minimum bending radius or otherwise damage the cable. Temporarily coil and store the existing fiber-optic cable overhead in a manner approved by the Engineer until the new drop cable can be spliced into the existing cable in an aerial splice enclosure. Once splicing has been completed, furnish and install fiber-optic cable storage guides and permanently store all remaining spare cable.

Using an OTDR, test the end-to-end connectivity of the drop cable from patch panel installed inside the signal or CCTV cabinet to the adjacent managed Ethernet switches. Comply with the OTDR testing and reporting requirements of the "Fiber-Optic Splice Centers" section of these Project Special Provisions when testing drop cable.

F. Aerial Cable Protector

Where shown in Plans and as directed by the Engineer, at locations where aerial fiber-optic communications cables are subject to damage by tree limb abrasion, install cable protectors over the fiber-optic cable that are of sufficient length to protect the cable from the potential threat as directed by the Engineer. Do not install aerial cable protectors at any locations without the prior approval of the Engineer. Do not install cable protectors for lengths of application that are shorter or longer than approved/directed by the Engineer.

17.4. MEASUREMENT AND PAYMENT

Communications cable (____-fiber) will be measured and paid as the actual linear feet of fiber-optic cable of each fiber count furnished, installed, and accepted according to the following conditions: 80% of the payment will be made upon acceptance of the installed cable and the remaining 20% of the payment will be made following splicing, testing and final acceptance (including completion of the 60-day Observation Period). Measurement will be made by calculating the difference in length markings located on outer jacket from start of run to end of run for each run. Terminate all fibers before determining length of cable run.

Plenum-rated communications cable (____-fiber) will be measured and paid as the actual linear feet of fiber-optic cable of each fiber count furnished, installed, and accepted according to the following conditions: 80% of the payment will be made upon acceptance of the installed cable and the remaining 20% of the payment will be made following splicing, testing and final acceptance (including completion of the 60-day Observation Period). Measurement will be made by calculating the difference in length markings located on outer jacket from start of run to end of run for each run. Terminate all fibers before determining length of cable run.

Drop cable will be measured and paid as the actual linear feet of fiber-optic drop cable comprised of a minimum of 12 fibers that are furnished, installed, and accepted according to the following conditions: 80% of the payment will be made upon acceptance of the installed and spliced drop cable, and the remaining 20% of the payment will be made following final acceptance (including completion of the 60-day Observation Period).

Aerial cable protector will be measured and paid as the actual linear feet of aerial cable protector furnished, installed, and accepted. No measurement and payment will be made of any aerial cable protector installed without the prior approval of the Engineer or for cable protector installed at locations or for lengths of application other than approved or directed by the Engineer.

◆ **Revision No. 1, April 10, 2017 – This document supersedes version originally issued and sealed by J. Todd Brooks, NCPE No. 017586 on 12/28/2016.**

U-4715B**ITS-139****Buncombe County**

No measurement will be made for terminating, splicing, and testing fiber-optic cable, communications cable identification markers, fiber-optic cable storage guides, SMFO jumpers and pigtails, mechanical sealing devices and conduit seals/sealing putty, as these will be considered incidental to the installation of fiber-optic cable and drop cables.

No measurement will be made of removing existing cables from existing risers as such removals will be considered incidental to furnishing and installing the fiber-optic cables and drop cables.

No measurement will be made of clearing a blockage or obstruction from an existing conduit necessary to install a communications cable in an existing underground conduit as such work will be considered incidental to installation of the communications cable.

No measurement will be for installing a pull tape inside of and sealing the ends of an existing conduit that will be retained for future use after removing an existing communications cable from that conduit as such work will be considered incidental to installation of new fiber-optic communications cable.

No measurement will be made of removing existing weatherheads, sealing bushings, heat shrink tubing and riser caps to install new fiber-optic drop cables in existing risers as such removals will be considered incidental to furnishing and installing heat shrink tubing retrofit kits. Heat shrink tubing retrofit kits will be measured and paid for in accordance with the "Riser Assemblies" section of these Project Special Provisions.

Payment will be made under:

| Pay Item | Pay Unit |
|--|-----------------|
| Communications Cable (24-Fiber) | Linear Foot |
| Communications Cable (60-Fiber) | Linear Foot |
| Communications Cable (96-Fiber) | Linear Foot |
| Plenum-rated Communications Cable (24-fiber) | Linear Foot |
| Drop Cable | Linear Foot |
| Aerial Cable Protector | Linear Foot |

◆ **Revision No. 1, April 10, 2017 – This document supersedes version originally issued and sealed by J. Todd Brooks, NCPE No. 017586 on 12/28/2016.**

18. FIBER-OPTIC SPLICE CENTERS

18.1. DESCRIPTION

Furnish and install fiber-optic interconnect centers, fiber-optic splice enclosures, and all necessary hardware.

Modify existing fiber-optic interconnect centers and/or splice enclosures as shown in the plans. Refer to manufacturer's recommendations for opening, modifying and re-sealing the existing fiber-optic interconnect center and/or fiber-optic splice enclosure.

18.2. MATERIALS

Furnish material, equipment, and hardware furnished under this section that is pre-approved on the ITS and Signals QPL.

A. Interconnect Center

Furnish compact, modular interconnect centers designed to mount inside equipment cabinets. Design and size interconnect centers to accommodate all fibers entering cabinets. Provide interconnect centers for controller cabinets and CCTV cabinets that are one rack unit (RU) high.

Provide splice trays that hold, protect, organize optical fibers, and secure fibers inside splice tray. Design and size the splice trays to be dielectric, to accommodate all fibers entering splice tray, and to provide sufficient space to prevent microbending of optical fibers. Provide connector panels with LC-type connectors.

Furnish SMFO pigtails with each interconnect center. Provide pigtails that are a maximum of 6 feet in length with factory-assembled LC connectors on one end. Ensure SMFO pigtails meet the operating characteristics of the SMFO cable with which it is to be coupled.

For connecting Ethernet edge switches to the interconnect center patch panels, furnish SMFO jumpers that are a minimum of 3 feet in length with factory-assembled LC connectors on one end (i.e., the interconnect center end) and, on the other end, factory-assembled connectors of the same type provided on the Ethernet edge switch. Ensure SMFO jumpers meet the operating characteristics of the SMFO cable with which it is to be coupled.

B. Splice Enclosure

Furnish splice enclosures that are re-enterable using a mechanical dome-to-base seal with a flash test valve, and are impervious to the entry of foreign material (water, dust, etc.). Ensure enclosures are manufactured in such a manner to be suitable for aerial, pedestal, buried, junction box, and manhole installation.

Provide enclosures with a minimum of one oversized oval port that will accept two cables and with a minimum of four round ports (for single cables) that will accommodate all cables entering enclosure. Provide heat shrink cable shields with enclosure to ensure weather-tight seal where each cable enters enclosure.

Within enclosures, provide enough hinged mountable splice trays to store the number of splices required, plus the capacity to house six additional splices. Provide a fiber containment basket for storage of loose buffer tubes expressed (i.e., uncut and unspliced) through the

◆ **Revision No. 1, April 10, 2017 – This document supersedes version originally issued and sealed by J. Todd Brooks, NCPE No. 017586 on 12/28/2016.**

enclosure. Ensure enclosures allow sufficient space to prevent microbending of buffer tubes when coiled.

Provide splice trays that hold, protect, organize optical fibers, and secure fibers inside splice tray. Provide splice trays that are dielectric.

C. Existing Splice Enclosures

When adding a new fiber-optic cable to an existing splice enclosure or otherwise modifying an existing splice inside an existing splice enclosure, furnish heat shrink cable shields that are compatible with the enclosure to ensure weather-tight seal where each new cable enters the existing enclosure and to replace any existing seals that are broken or removed while modifying the splice.

Provide splice trays that hold, protect, organize optical fibers, and secure fibers inside splice tray for new or modified splices inside existing splice enclosures and interconnect centers. Provide splice trays that are dielectric and that are compatible with the existing splice enclosure or interconnect center. Provide splice trays that are sized to accommodate all fibers entering the splice tray and to provide sufficient space to prevent microbending of optical fibers.

Furnish SMFO pigtails for terminating new fibers on the connector panel of an existing interconnect center. Provide pigtails that are a maximum of 6 feet in length with factory-assembled LC connectors on one end. Ensure SMFO pigtails meet the operating characteristics of the SMFO cable with which it is to be coupled. Provide connector panels with LC-type connectors that are compatible with the existing interconnect center.

For connecting Ethernet edge switches to the interconnect center patch panel, furnish SMFO jumpers that are a minimum of 3 feet in length with factory-assembled LC connectors on one end (i.e., the interconnect center end) and, on the other end, factory-assembled connectors of the same type provided on the Ethernet edge switch. Ensure SMFO jumpers meet the operating characteristics of the SMFO cable with which it is to be coupled.

18.3. CONSTRUCTION METHODS

A. General (Workmanship Identification Information)

Include on the cover of each splice tray in a legible format the following workmanship identification information:

- Splice location reference # or identification information (e.g., 13-xxxx tray 1 of 3, 13-xxxx tray 2 of 3, etc.);
- Date the splice was made;
- Name of company that performed the splicing;
- Name of person who performed the splicing.

B. Workmanship

Upon cutting the cable and removing the outer jacketing material down to the individual buffer tubes, secure the central strength member to the enclosure so that no tensile force is applied to the fibers. Secure the individual buffer tubes to the splice trays by a method recommended by the manufacturer. Determine the length of each buffer tube needed to ensure that the buffer tube can be looped a minimum of two times around the inside of the splice tray. Upon determining the length of buffer tube needed, remove the buffer tube to expose the

◆ **Revision No. 1, April 10, 2017 – This document supersedes version originally issued and sealed by J. Todd Brooks, NCPE No. 017586 on 12/28/2016.**

U-4715B**ITS-142****Buncombe County**

individual fibers for fusion splicing. Adjust individual fiber lengths as necessary to ensure that once the fusion splicing process is completed the finished splices will align with the “splice block organizer” supplied within the splice tray. Ensure the splice block organizer has individual fusion splice space holders for each fiber splice.

While prepping the individual fibers for splicing, install the heat shrink protective tube over the fiber and then perform the splicing operations, following the manufacturer’s instructions. Verify that the newly formed splice does not exceed 0.05 dB of attenuation. If the attenuation is more than 0.05 dB, then remake the splice until it meets the 0.05 dB or less requirement. Finish the splicing operation by sliding the heat shrink tube over the splice and applying heat to activate the heat shrink tubing. Secure the finished splice in the splice block organizer. Ensure each splice is properly secured in a space holder in the splice block organizer. Multiple splices secured to the same space holder are unacceptable.

Ensure all buffer tubes are contained within splice trays so that no bare fibers are outside of the tray. Do not damage the fibers or violate the minimum bend radius of the fiber.

Prior to installing the cover over the splice tray and placing it in its final resting location, take a MANDATORY digital photograph of the splice tray that shows the final workmanship. Ensure that the photograph shows the “Workmanship Identification Information” as well as the workmanship associated with installing and terminating the fiber. Ensure that the photograph is clear, in-focus and information captured is legible. Include digital copies of each photograph on a compact disc as part of the OTDR Test Results submittal.

C. Termination and Splicing within Interconnect Centers

Terminate and fusion splice all fibers as shown in the Plans.

Label all fiber-optic connectors, whether on jumpers, connector panels, or other equipment, to prevent improper connection. Obtain approval of fiber-optic connector labeling method.

For all fibers designated for termination to a connector panel within an interconnect center, fusion splice the fibers to pigtails.

For all fibers designated to pass through interconnect center, neatly coil and express the fibers without cutting. For all buffer tubes designated to pass through interconnect center, neatly coil excess tubing inside interconnect center.

D. Interconnect Centers in Controller and CCTV Cabinets

Install interconnect centers with connector panels, splice trays, storage for slack cable or fibers, mounting and strain relief hardware, and all necessary hardware. Mount the interconnect center in the rack inside the controller cabinet or CCTV cabinet at the location indicated in the Plans. Install SMFO jumpers between the appropriate connectors on the interconnect center and the Ethernet edge switch.

E. Replacement of Interconnect Centers Installed under STIP Project I-5504

New controller cabinets with interconnect centers and new fiber-optic drop cables are being installed by another contractor at the following locations along Brevard Road as part of construction of NCDOT STIP Project I-5504:

◆ **Revision No. 1, April 10, 2017 – This document supersedes version originally issued and sealed by J. Todd Brooks, NCPE No. 017586 on 12/28/2016.**

U-4715B

ITS-143

Buncombe County

| Signal Inventory No. | Intersection Name |
|----------------------|--|
| 13-0647 | NC 191 (Brevard Road) at Asheville Outlet Entrance |
| 13-1283 | NC 191 (Brevard Road) at Petco Entrance |
| 13-0514 | NC 191 (Brevard Road) at I-26 EB Ramps |
| 13-1284 | NC 191 (Brevard Road) at I-26 WB Ramps |

These controller cabinet assemblies will be removed and replaced with new controllers with cabinets in the same location under this U-4715B Asheville Signal System project but the existing fiber-optic drop cables to the cabinets will be retained. When changing out these controller cabinets, first disconnect the existing fiber-optic drop cable from the existing cabinet-mounted interconnect center, then carefully coil and place the existing drop cable in the base of the cabinet. Once the drop cable has been disconnected and stored, remove the existing controller cabinet assembly, then install the new controller cabinet assembly on the existing base. Route the stored existing drop cable to the new cabinet-mounted interconnect center, then fusion splice the drop cable fibers to new fiber-optic pigtails and terminate them on the interconnect center patch panel in accordance with splice details in the Plans. Comply with “Termination and Splicing within Interconnect Centers” and “Interconnect Centers in Controller and CCTV Cabinets” subsections above.

F. Termination and Splicing within Splice Enclosure

Install splice enclosures with splice trays, basket containment assemblies, racking for slack cable or fibers, mounting and strain relief hardware, and all other necessary hardware. Install separate splice enclosures for the signal system fiber-optic cables.

Do not install aerial splice enclosures and storage guides over roadways or driveways.

Fusion splice all fibers including fibers designated to be coupled with fibers from a drop cable. For all fibers designated to pass through splice enclosure, coil and express the fibers without cutting.

For all buffer tubes designated to pass through splice enclosure, neatly coil excess tubing inside basket provided with enclosure.

Label all fiber-optic splices. Obtain approval of fiber-optic connector labeling method.

Install heat shrink cable shields using methods recommended by the manufacturer of the enclosure. Perform a pressurization flash test on enclosure in accordance with manufacturer’s recommended procedures at the conclusion of splicing procedure and before final placement of enclosure.

For aerial installations, secure enclosures to messenger cable using manufacturer supplied hardware. Secure SMFO cable and drop cables to snowshoes.

Install enclosures with enough slack cable to allow enclosure to be lowered to ground level and extended into a splicing vehicle.

◆ **Revision No. 1, April 10, 2017 – This document supersedes version originally issued and sealed by J. Todd Brooks, NCPE No. 017586 on 12/28/2016.**

U-4715B**ITS-144****Buncombe County**

For underground, manhole and junction box facility installations, place the enclosure along with required spare cables in the facility in a neat and workmanship like manner. Install underground splice enclosures only in special-sized junction boxes unless the Plans indicate otherwise or the Engineer approves otherwise.

G. Modify Existing Splice

Modify existing fiber-optic interconnect centers and/or splice enclosures as shown in the Plans. Terminate and splice new fibers and re-splice existing fibers within existing interconnect centers and splice enclosures as shown on the Plans. Use existing splice trays, where available, inside the splice center and install additional patch panels, splice trays and pigtails where necessary and fusion splice fiber connections as required by the Plans, then perform OTDR testing. Provide new splice trays that are compatible with the existing splice enclosures when previously unspliced buffer tubes are spliced. Install new fiber-optic jumpers and make connections to Ethernet edge switches and Ethernet core switch, other equipment and/or patch panels as necessary. Comply with all requirements of “Interconnect Center” and “Splice Enclosure” subsections above.

Install new fiber-optic jumpers and make connections to Ethernet edge switches, Ethernet core switch and other equipment and/or patch panels as necessary. Comply with all requirements of the “Interconnect Center” and “Splice Enclosure” subsections above.

Relocate existing aerial splice enclosure and corresponding existing fiber-optic cable storage rack(s) as shown on the Plans. Unlash existing, reroute and relash existing fiber-optic cable as required to relocate the existing aerial splice enclosure.

H. Testing

Provide written notification to the Engineer a minimum of 10 working days before beginning the OTDR tests.

After splicing is completed, perform bi-directional OTDR tests on each fiber, including unused fibers. Install a 1,000-foot pre-tested launch cable between the OTDR and fiber-optic cable to be tested and a 1,000-foot pre-tested destination cable on the end of the fiber-optic cable to be tested. Ensure each launch cable has been tested and is compatible with the fiber-optic cable being installed. Provide the Engineer with test results of the launch cable before use. Retest or replace launch cable at the Engineer’s request.

Ensure fusion splice losses do not exceed 0.05 dB and connectors have a loss of 0.5 dB or less. If any fiber exceeds maximum allowable attenuation or if fiber-optic properties of the cable have been impaired, take appropriate actions up to and including replacement of the fiber-optic cable. Corrective action will be at no additional cost to the Department.

Clearly label each OTDR trace identifying a starting and ending point for all fibers being tested. Record the attenuation level of each fiber and clearly indicate OTDR trace results in report format. Furnish two hard copies of each of the OTDR trace results and electronic copies of all trace results along with digital photographs showing workmanship for each splice on a compact disc. Furnish the manufacturer’s make, model number and software version of the OTDR used for testing.

Provide the Engineer with two copies of the software needed to view the OTDR traces electronically.

◆ **Revision No. 1, April 10, 2017 – This document supersedes version originally issued and sealed by J. Todd Brooks, NCPE No. 017586 on 12/28/2016.**

U-4715B

ITS-145

Buncombe County

18.4. MEASUREMENT AND PAYMENT

Interconnect center will be measured and paid as the actual number of fiber-optic interconnect centers furnished, installed, and accepted according to following conditions: 80% of the payment will be made upon acceptance of the installed interconnect centers and the remaining 20% of the payment will be made following final acceptance (including completion of the 60-day observation period).

Splice enclosure will be measured and paid as the actual number of fiber-optic splice enclosures that are furnished, installed, and accepted, regardless of installation location (i.e., aerial, underground, manhole, or junction box), according to following conditions: 80% of the payment will be made upon acceptance of the installed splice enclosures and the remaining 20% of the payment will be made following final acceptance (including completion of the 60-day Observation Period).

Modify existing splice will be measured and paid as the actual number of existing fiber-optic splice enclosures, interconnect centers and splice centers where existing splices are reconfigured, new fibers are spliced to existing fibers and new fibers are terminated in the existing splice center. Measurement will be made per existing splice enclosure without regard to type and location of splice enclosure and without regard to the number of splices and terminations required at each location. Payment for modify existing splice will be full compensation for all materials and work required to modify the existing splices in accordance with the plans. No measurement will be made of cable addition kits, grommet inserts, heat shrink tubing, splice trays and splice protectors as such work will be considered incidental to modifying the existing splice. No measurement will be made of relocating an existing aerial splice enclosure and associated fiber-optic cable storage guide(s) as such work will be considered incidental to modifying the existing splice.

No measurement will be made of fusion splices, splice trays, splice protectors, pigtails, jumpers, connector panels, labeling, photographs, testing and corrective actions, repairs and replacements needed due to exceeding the maximum allowable attenuation or other defects, as these will be considered incidental to furnishing and installing fiber-optic interconnect centers and splice enclosures, and modifying existing splices.

No measurement will be made for disconnect fiber-optic drop cables from existing interconnect centers and temporarily storing the existing cable in existing equipment cabinets, removal of existing splice centers, including existing interconnect centers and splice enclosures, as such work will be considered incidental to furnishing and installing fiber-optic interconnect centers and splice enclosures.

Payment will be made under:

| Pay Item | Pay Unit |
|------------------------|-----------------|
| Interconnect Center | Each |
| Splice Enclosure | Each |
| Modify Existing Splice | Each |

◆ **Revision No. 1, April 10, 2017 – This document supersedes version originally issued and sealed by J. Todd Brooks, NCPE No. 017586 on 12/28/2016.**

19. DELINEATOR MARKERS

19.1. DESCRIPTION

Furnish and install delineator markers (tubular marker posts) with all necessary hardware and adhesives to warn of buried fiber-optic communications cable.

19.2. MATERIALS

A. Delineator Markers

Furnish material, equipment, and hardware under this section that is pre-approved on the ITS and Signals QPL.

Furnish delineator markers, also referred to as tubular marker posts that are approximately 6 feet long and constructed of Type III, high-density polyethylene (HDPE) material. Provide delineator assemblies that are ultraviolet stabilized to help prevent components from color fading, warping, absorbing water, and deterioration with prolonged exposure to the elements. Provide delineators designed to self-erect after being knocked down or pushed over. Provide orange delineator posts.

Provide text, including Department contact number, hot stamped in black on a yellow reflective background material that will not fade or deteriorate over time. Provide delineator markers with nominal message height of 15" that contain the following text visible from all directions approaching the assembly:

| | |
|--|--|
| W A R N I N G | F I B E R O P T I C C A B L E S |
| BEFORE EXCAVATING OR IN AN EMERGENCY CALL (828) 298-0094 | |
| NORTH CAROLINA DEPARTMENT OF TRANSPORTATION | |

◆ **Revision No. 1, April 10, 2017 – This document supersedes version originally issued and sealed by J. Todd Brooks, NCPE No. 017586 on 12/28/2016.**

U-4715B

ITS-147

Buncombe County

19.3. CONSTRUCTION METHODS

A. Delineator Markers in Historic Districts

Obtain the Engineer’s approval prior to installing any delineator markers within historic districts. The Engineer may modify the application criteria described herein or delete the requirement for some or all cable markers based upon the requirements of the particular historic district.

B. Delineator Markers

Submit sample of proposed delineator markers for approval before installation.

Install delineator markers using a method that firmly and securely anchors delineator marker in the ground to prohibit twisting and easy removal.

Install delineator markers at locations specified on the plans. Do not install delineator markers at locations other than those specified in the Plans without the prior approval of the Engineer.

19.4. MEASUREMENT AND PAYMENT

Delineator marker will be measured and paid for as the actual number of delineator markers (tubular marker posts) furnished, installed, and accepted.

Payment will be made under:

| Pay Item | Pay Unit |
|-------------------|-----------------|
| Delineator Marker | Each |

U-4715B

ITS-148

Buncombe County

20. REMOVE EXISTING COMMUNICATIONS CABLE

20.1. DESCRIPTION

Remove existing communications cable. Remove existing communications cable splice boxes/cabinets, hub cabinets, cabinet foundations, associated risers and in-ground junction boxes as designated in the Plans.

20.2. MATERIALS

Furnish rigid galvanized threaded pipe caps or rigid galvanized threaded pipe plugs to seal the ends of vertical conduits after “short risers” underneath pole-mounted cabinets are cutoff near ground level.

Furnish pipe caps or pipe plugs to seal the ends (i.e., tops) of 2” rigid galvanized steel risers from which fiber-optic cable and heat shrink tubing (or sealing bushing) are removed but not reinstalled (i.e., vacated existing fiber-optic cable risers). Provide heat-stabilized vinyl or plastic, non-threaded pipe cap or other Engineer-approved removable seal for top of vacated communications cable risers that are not removed. Refer to the “Risers” section of these Project Special Provisions for additional requirements for such riser caps.

Furnish heavy duty, dielectric, heat-shrink end caps designed to seal off and provide mechanical and mechanical protection to the ends of electrical and telecommunications cables. Provide end caps appropriated sized for the cables that they will be sealing.

20.3. CONSTRUCTION METHODS

A. General

Do not reuse any removed communications cable, messenger cable, junction boxes, pole attachment hardware or abandoned risers on the project, unless otherwise specified.

Only remove existing communications cable where called out in the Plans and where directed by the Engineer; otherwise, do not remove the existing communications cable.

B. Removal of Aerial Communications Cable

Removal of existing aerial communications cable includes removal and proper disposal of aerial splice enclosures, messenger cable and mounting hardware, associated guy assemblies, splice boxes and splice cabinets as well as vacated risers attached to splice boxes and cabinets that are being removed. Communications cable removal also includes removal of existing PVC risers that are vacated when the communications cable is removed. Retain and cap/plug tops of all other existing rigid galvanized steel risers vacated when communications cable is removed, unless the Engineer directs otherwise. Removal of guy assemblies includes the removal of guy anchors if not used by any other guy assembly.

Unless otherwise directed by the Engineer, remove and properly dispose of existing wood poles that are vacated upon removal of the existing communications cable (i.e., where the communications cable was the only attachment to the pole).

◆ **Revision No. 1, April 10, 2017 – This document supersedes version originally issued and sealed by J. Todd Brooks, NCPE No. 017586 on 12/28/2016.**

C. Removal of Underground Communications Cable

Removal of existing underground communications cable includes proper disposal of junction boxes, if required. Where junction boxes have been removed, backfill hole to 95% of surrounding density and finish level with surrounding ground.

When removing existing communications cable from an underground conduit that will be retained for future use, install a pull tape in the vacated underground conduit in conjunction with or immediately following removal of the existing cable. Seal the ends of the vacated conduit with an approved duct plug or duct and conduit sealer following installation of the pull tape.

When the Contractor has made reasonable attempts to remove an existing communications cable but is unable to do so as confirmed by the Engineer, carefully cut the existing cable close to the end of the conduit/duct, leaving just enough cable exposed to apply a heat shrink end cap over the end of the cable. Clean and prepare end of cable in accordance with heat shrink cable end cap manufacturer's instructions. Install a heat shrink cap appropriately sized for the cable being sealed over the end of the cable, then abandon the cable in the existing conduit/duct. Remove and dispose of the severed cable remnant.

At pole-mounted controller cabinets that have an existing short riser that conveys existing communications cable directly into the bottom of the cabinet from an underground conduit run and that short riser will not be retained for installation of a new fiber-optic drop cable, remove the short riser and existing communications cable as follows:

1. Disconnect the communications cable inside the pole-mounted controller cabinet.
2. Disconnect the short riser from the bottom of the cabinet and then cut off the short riser and communications cable flush with the sidewalk below the cabinet or at least 6 inches below ground where there is no sidewalk.
3. Where the short riser free-standing (i.e., offset from and not attached to pole from ground bottom of cabinet) and is within sidewalk below the cabinet, cut-off the short riser below grade (i.e., beneath the sidewalk) and replace the affected slab of sidewalk. Where the freestanding riser is in an unpaved area, cut off the short riser below ground and back fill over the top. If the short riser is attached to the pole (not offset), install a cap or plug the short riser at its current height.

Subject to the Engineer's approval, existing communications cable being removed may be used as a pull line to install the new fiber-optic communications cable in its place in the existing underground conduit. Comply with the installation requirements in the "Fiber-Optic Cable" section of these Project Special Provisions when installing then new fiber-optic cable in existing underground conduit.

D. Removal of Splice/Hub Cabinet

Remove existing splice/hub cabinet and, where cabinet is base-mounted, remove existing cabinet foundation. Where the existing conduits entering the base-mounted cabinet will be retained to convey the new fiber-optic communications cable, install an oversize heavy-duty junction box over the existing conduit stubouts that remain upon removal of existing splice/hub cabinet foundation. Where the existing conduits entering the base-mounted cabinet will be abandoned, cut the conduits off a minimum of 12 inches below ground and backfill the hole even with the surrounding ground immediately following removal of the existing splice/hub cabinet

◆ **Revision No. 1, April 10, 2017 – This document supersedes version originally issued and sealed by J. Todd Brooks, NCPE No. 017586 on 12/28/2016.**

foundation. Restore the ground surface to the condition of the surrounding area. If the removed foundation is in a concrete sidewalk, replace the entire concrete slab from joint-to-joint with new concrete sidewalk, using the same type of concrete. If the removed foundation is in a bricked sidewalk, this shall include filling in the area with brick pavers that match the surrounding area, as approved by the Engineer. Comply with the requirements for the removal of existing material in Section 1 of these Project Special Provisions. Comply with the “Signal Cabinet Foundations” section of these Project Special Provisions concerning replacement of existing sidewalks.

20.4. MEASUREMENT AND PAYMENT

Remove existing communications cable will be measured in horizontal linear feet of existing communications cable removed and accepted. Payment will be in linear feet. Sag, vertical segments, and spare segments of communications cable will not be paid for, as these distances will be considered incidental to the removal of existing communications cable.

No additional measurement will be made for multiple communications cables being removed from the same underground conduit or same pole. No payment will be made for communications cable that cannot be removed and is abandoned in place.

No measurement will be made of the removal of messenger cable, pole attachment hardware, guy assemblies, aerial splice enclosures, wood poles, stub poles, risers (where removal is required by this Project Special Provision or by the Engineer) and in-ground junction boxes vacated upon removal of the existing communications cable, as these will be considered incidental to the removal of the existing communication cable.

No measurement will be made for installing a pull tape inside of and sealing the ends of an existing conduit that will be retained for future use after removing an existing communications cable from that conduit as such work will be considered incidental to installation of new fiber-optic communications cable.

Remove splice/hub cabinet will be measured as the actual number of existing communications cable splice cabinets and hub cabinets successfully removed, disposed of and accepted without regard to the size or type of cabinet/box, mounting location or mounting method. Such payment includes removal and disposal of existing splice centers housed inside the cabinet, cabinet base adapters and base extenders for base-mounted cabinets and mounting brackets and hardware for pole-mounted cabinets.

No measurement will be made of the removal of risers vacated upon removal of existing splice boxes/cabinets and associated communications cable and of pipe caps and pipe plugs installed on vacated risers that are retained (left in place), as these will be considered incidental to the removal of the existing splice box/cabinet and the existing communications cable. No measurement will be made of conduit plugs.

Remove splice/hub cabinet foundation will be measured as the actual number of existing communications cable splice/hub cabinet foundations successfully removed, disposed of and accepted without regard to the size of the foundation. Such payment will include all labor and materials required to cutoff existing conduits below ground and backfill the area even with the surrounding ground upon removal of the cabinet foundation. Where called for in the plans, junction boxes installed over existing conduit stubouts remaining after removal of the cabinet foundation will be measured and paid for in accordance with the “Junction Boxes” section of these Project Special Provisions. Repair and replacement of existing sidewalk following

◆ **Revision No. 1, April 10, 2017 – This document supersedes version originally issued and sealed by J. Todd Brooks, NCPE No. 017586 on 12/28/2016.**

U-4715B

ITS-151

Buncombe County

removal of a splice/hub cabinet foundation located in an existing sidewalk will be measured and paid for in accordance with the “Signal Cabinet Foundations” section of these Project Special Provisions.

Payment will be made under:

| Pay Item | Pay Unit |
|--------------------------------------|-----------------|
| Remove Existing Communications Cable | Linear Foot |
| Remove Splice/Hub Cabinet | Each |
| Remove Splice/Hub Cabinet Foundation | Each |

◆ **Revision No. 1, April 10, 2017 – This document supersedes version originally issued and sealed by J. Todd Brooks, NCPE No. 017586 on 12/28/2016.**

21. CABLE TRANSFERS

21.1. DESCRIPTION

Remove and reinstall existing communications cable for pole relocations.

21.2. CONSTRUCTION METHODS

During the project, transfers of existing communications cable from one pole to an adjacent pole or from one attachment point to a new attachment point on the same pole may be required. Perform transfers as directed by the Engineer.

For pole-to-pole transfers, remove existing cable from the pole and reinstall the cable and any existing attachment hardware on the adjacent second pole. Remove all communications hardware from first pole from which the cable was removed.

For attachment-point-to-attachment-point transfers on the same pole, drill a hole in the pole and install a strandvise for dead-end attachment of the cable as called for in the Plans, relocate the messenger cable from the existing 3-bolt clamp to the new strandvise, and remove the existing 3-bolt clamp. Install new guy assembly for dead-end span as shown in the Plans.

Furnish and install any new attachment hardware as required.

21.3. MEASUREMENT AND PAYMENT

Cable transfer will be measured and paid as the actual number of cable transfers with attachment hardware from one pole to an adjacent pole or from one attachment point to a new attachment point on the same pole furnished, installed, and accepted.

Payment will be made under:

| Pay Item | Pay Unit |
|-----------------|-----------------|
| Cable Transfer | Each |

22. SIGNAL PEDESTALS

22.1. DESCRIPTION

Furnish and install signal pedestal assemblies with foundations, grounding systems, and all necessary hardware.

22.2. MATERIALS

Furnish material, equipment, and hardware under this section that is pre-approved on the ITS and Signals QPL.

Furnish pedestal assemblies with foundations that conform to the latest edition of the *AASHTO Standard Specifications for Structural Supports for Highway Signs, Luminaires, and Traffic Signals* in effect on the date of project advertisement. Refer to *Roadway Standard Drawings* No. 1743 for structural design specifications for each type of pedestal.

Refer to Articles 1091-6, "Grounding Electrodes" and 1091-2, "Wire and Cable" of the *Standard Specifications*.

A. Pedestal Shaft

Furnish one piece pedestal shafts fabricated from either aluminum or galvanized steel pipe with a uniform pipe outer diameter of 4.5" and of the lengths specified for the type of pedestal shown on *Roadway Standard Drawing* No. 1743.

Pedestals are defined as follows:

- Type I – Pedestrian Pushbutton Post
- Type II – Normal-Duty Pedestal
- Type III – Heavy-Duty Pedestal

For Type I (pedestrian pushbutton pedestals) and Type II (normal-duty pedestals), furnish shafts constructed from schedule 40 extruded aluminum pipe that conforms to Aluminum Association Alloy 6063-T6 with a tensile strength of 30 KSI and a minimum wall thickness of 0.237". Aluminum conduit will not develop the necessary strength required and is not allowed. Thread and deburr in accordance with American National Standard Pipe Threads, NPT (ANSI B2.1). Finish the exterior with a rough surface texture consisting of a uniform grain pattern that is perpendicular to the axis of the pipe along the full pipe length. Unless otherwise specified, do not use galvanized steel pipe for Type I and Type II pedestal shafts.

For Type III (heavy-duty pedestals), furnish schedule 1 120 galvanized steel pipe that conforms to ASTM A53. Provide an 11" square by 1" thick steel base plate with minimum yield strength of 36 ksi that conforms to ASTM A36. Fabricate the base plate with four equally spaced bolt holes on an 11" bolt circle. Orient the bolt holes in the corners of the plate. Size the holes to accommodate 1" diameter machine bolts. Weld the pedestal shaft to the center of the base plate using a socket connection. Provide circumferential fillet welds at the top and bottom of the base plate. Perform all welding in accordance with the latest AWS Code. Hot-dip galvanize the pedestal shaft and base plate assembly after fabrication in accordance with ASTM A123. Unless otherwise specified, do not use aluminum pipe for Type III pedestal shafts.

◆ **Revision No. 1, April 10, 2017 – This document supersedes version originally issued and sealed by J. Todd Brooks, NCPE No. 017586 on 12/28/2016.**

B. Transformer Bases

Furnish transformer bases for each type of pedestal shown on *Roadway Standard Drawings* No. 1743 fabricated from aluminum that meets Aluminum Association Alloy 356 or equivalent, and that are designed to break upon impact in accordance with AASHTO requirements. Submit FHWA certification for each type of transformer base that reflects compliance with NCHRP 350. For use in grounding and bonding, provide a 0.5" minimum diameter, coarse thread hole cast into transformer base located inside base and oriented for easy access.

Provide a minimum access opening for all transformer bases of 8" x 8" with an access door that is attached with stainless steel hinges on one side of the transformer base. Provide a 1/4" x 3/4" long stainless steel vandal proof screw to secure access door.

For Type I (pedestrian pushbutton pedestals) and Type II (normal-duty pedestals), provide overall base dimensions of 15" (l) x 13 3/4" (w) x 13 3/4" (d) for square bases and 14" (l) x 16 1/2" (w) x 16 1/2" (d) for octagonal bases. Provide a threaded opening at the top of the base to receive a 4" NPT pipe shaft. Fabricate the bottom of the transformer base with 4 equally spaced holes or slots for a 12" bolt circle to secure the entire assembly to the concrete foundation.

For Type III (heavy-duty pedestals), provide square bases with overall dimensions of 17" (l) x 13" (w) x 13" (d). Fabricate the top of the transformer base with 4 equally spaced holes or slots for an 11" bolt circle to attach the pedestal shaft. Size the holes or slots to accommodate 1" diameter machine bolts. Fabricate the bottom of the transformer base with 4 equally spaced holes or slots for a 12" bolt circle to secure the entire assembly to the concrete foundation. Size the holes or slots to accommodate 1" diameter anchor bolts. Provide the following mounting hardware for heavy-duty pedestals:

- 1) Four 1" diameter by 3 1/2" long machine bolts (ASTM F593), with heavy hex nuts (ASTM A563 Grade DH, or A 194 Grade 2H), and thick flat washers, and lock washers (ASTM F436) per pedestal assembly. Galvanize in accordance with ASTM A153.
- 2) Three heavy hex nuts (ASTM A563 Grade DH, or A194 Grade 2H), 2 thick flat washers, and one lock washer (ASTM F436) for each anchor bolt. Galvanize in accordance with ASTM A153.
- 3) Six minimum slotted stainless steel shims of necessary thickness for leveling per pedestal assembly.

C. Anchor Bolts

For each pedestal, provide 4 anchor bolts in accordance with ASTM F1554, Grade 55, of the size and length specified in *Roadway Standard Drawings* No. 1743 each having one heavy hex nut with 2 washers at the top and 2 heavy hex nuts with one washer at the bottom. Provide anchor bolts with coarse threads at 10 threads per inch for a minimum length of 4" from each end of the bolt. All thread anchor rods may be used. Ensure anchor bolts are hot-dipped galvanized in accordance with ASTM A153 with completely galvanized nuts and washers. Provide hex nuts with coarse threads. Ensure hex nuts are in accordance with ASTM A563 Grade DH, ASTM A194, Grade 2H or equivalent. Ensure washers are in accordance with ASTM F436 or equivalent. As a minimum, provide standard size washers.

◆ **Revision No. 1, April 10, 2017 – This document supersedes version originally issued and sealed by J. Todd Brooks, NCPE No. 017586 on 12/28/2016.**

U-4715B

ITS-155

Buncombe County

D. Pedestal Cap

Furnish a 4-1/2" outside diameter slip fit domed pedestal top cap for each pedestal assembly designed to fit over the outside of the pedestal shaft. Fabricate the cap from aluminum that meets Aluminum Association Alloy 356. Ensure the cap provides 3 equally spaced stainless steel set screw fasteners to secure the cap to the pedestal shaft.

E. Pole Flange Base for 4 1/2" Pipe

Furnish a flange base with cover for use with Type I (pedestrian pushbutton pedestals) and Type II (normal-duty pedestals) only. Flange bases are non-breakaway supports that are to be used with a breakaway bolt system for AASHTO compliance for breakaway structures. Provide aluminum or steel flange bases with a minimum 7.5" diameter bolt circle. Ensure bases are either continuously welded to shafts or threaded to receive shafts. Each base should be designed to accommodate either three or four 1/2" bolts equally spaced on the bolt circle to receive breakaway anchors. Provide NPT threads on the internal opening of the flange base through the full length of the flange base with locking set screws at the top of the base to receive a 4" NPT pipe shaft.

Fabricate aluminum flange bases that meet Aluminum Association Alloy 356 requirements for architectural bases. Fabricate steel flange bases that meet ASTM A36.

Do not use flange bases for Type III pedestals.

F. Breakaway Anchors

Furnish single or double neck omnidirectional breakaway anchor bolt coupling systems for use with Type I (pedestrian pushbutton pedestals) and Type II (normal-duty pedestals) only. Use breakaway anchors that are FHWA certified to be compliant with NCHRP Report 350 as an alternative to transformer bases. Use with non-breakaway pole flange bases. Use 1/2" diameter bolts for pushbutton posts and 3/4" bolts for normal-duty pedestals. Fabricate from steel with a minimum yield strength of 55 KSI. Galvanize in accordance with ASTM A153. Do not use breakaway anchors with Type III pedestals, or in conjunction with breakaway transformer bases.

G. Foundation

Install pedestal foundations of the type and size shown on *Roadway Standard Drawings* No. 1743.04. Furnish Class A minimum concrete that conforms to Article 1000-4. Provide reinforcing steel that conforms to the applicable parts of Section 1070 of the *Standard Specifications*.

22.3. CONSTRUCTION METHODS**A. Type I Pedestrian Pushbutton Post**

Install pushbutton post for mounting pedestrian pushbutton (refer to "Signal Head" section of these Project Special Provisions).

Install underground conduit for pushbutton lead-in cable in the pushbutton post's concrete foundation.

Attach or anchor pushbutton post to the top of foundation via a breakaway support in a vertical plumb orientation. Ensure post is of sufficient length to accommodate the pushbutton, accessible pedestrian signals and any associated pedestrian informational signing at the mounting heights shown in the plans or *Roadway Standard Drawings* No. 1705 and 1743.

◆ **Revision No. 1, April 10, 2017 – This document supersedes version originally issued and sealed by J. Todd Brooks, NCPE No. 017586 on 12/28/2016.**

U-4715B

ITS-156

Buncombe County

B. Type II and III Pedestals

Locate foundations, determine elevation, and submit findings for normal-duty and heavy duty pedestals. Obtain the Engineer's approval of foundation locations and elevations before constructing foundations.

Excavate in accordance with Section 410, Foundation Excavation, of the *Standard Specifications*. If encountered, remove rock or boulders to a depth sufficient to obtain stability necessary to support the structure for design loads. Ensure ground is level before installing foundations.

Construct foundations in accordance with Section 825, Incidental Concrete Construction, of the *Standard Specifications*. Cast concrete for pole foundations against undisturbed soil unless otherwise permitted. Provide forms with chamfer strips that measure one inch along diagonal face at all corners above ground level. Do not install foundations over uncompacted fill or muck.

Install conduit in foundations.

Securely place, position, and align anchor bolts symmetrically about the center of foundation.

Give exposed vertical concrete surfaces an ordinary surface finish. Give exposed horizontal surfaces a float finish.

Level tops of concrete foundations. Do not allow tops to exceed 4 inches above adjacent ground surface. Pour and finish foundation to a level flush with surrounding sidewalk when possible.

Do not erect pedestals until concrete has attained a minimum compressive strength of 2,500 psi as determined by cylinder breaks.

Refer to *Roadway Standard Drawings* No. 1705 and 1743.

22.4. MEASUREMENT AND PAYMENT

Type I post with foundation will be measured and paid as the actual number of pushbutton posts furnished, installed, and accepted.

Type II pedestal with foundation will be measured and paid as the actual number of normal-duty pedestals with foundations furnished, installed, and accepted.

No measurement will be made for pedestal foundations, grounding systems and any peripheral pedestal mounting hardware as these are considered incidental to furnishing and installing pedestals.

Payment will be made under:

| Pay Item | Pay Unit |
|----------------------------------|-----------------|
| Type I Post with Foundation | Each |
| Type II Pedestal with Foundation | Each |

◆ **Revision No. 1, April 10, 2017 – This document supersedes version originally issued and sealed by J. Todd Brooks, NCPE No. 017586 on 12/28/2016.**

U-4715B

ITS-157

Buncombe County

23. SIGNS INSTALLED FOR SIGNALS

23.1. DESCRIPTION

Furnish and install signs for signals with approved cable hangers, rigid sign mounting brackets, U-channel posts, and all necessary hardware.

23.2. MATERIALS

Comply with Articles 1092-1, Signs and Hardware, and 1092-2 Retroreflective Sheeting, of the *Standard Specifications*.

Use Grade C retroreflective sheeting, except for black sheeting. Use non-reflective for black sheeting.

Conform to the message layout, size, and color as required in the *MUTCD*.

For messenger cable mounting, furnish either messenger cable hangers with free-swinging, 360° adjustable sign brackets or 3-bolt clamps as directed. Furnish aluminum, galvanized steel, or stainless steel sign supporting hardware.

For ground mounting, furnish steel, 3 lb., U-channel posts with hardware for ground mounting. Comply with Section 903, Ground Mounted Sign Supports of the *Standard Specifications*.

For mast-arm mounting, furnish rigid aluminum, galvanized steel or stainless steel sign mounting brackets.

23.3. CONSTRUCTION METHODS

Install signs with approved mounting hardware. Comply with sign offsets and mounting heights as shown in the *MUTCD* and NCDOT *Roadway Standard Drawing* No. 904.50.

For messenger cable mounting, install signs 6 inches minimum from signal heads.

For ground mounting, comply with Section 903, Ground Mounted Supports of the *Standard Specifications*.

For mast arm mounting, install attachment brackets to allow adjustment so signs:

- Are aimed in required direction,
- Are plumb as viewed from respective approaches,
- May be tilted forward or backward as required, and
- May be raised or lowered on mast arm throughout full length of sign.

23.4. MEASUREMENT AND PAYMENT

Sign for signals will be measured and paid as the actual number of signs for signals, regardless of mounting method, furnished, installed, and accepted.

Payment will be made under:

| Pay Item | Pay Unit |
|------------------|----------|
| Sign for Signals | Each |

◆ **Revision No. 1, April 10, 2017** – *This document supersedes version originally issued and sealed by J. Todd Brooks, NCPE No. 017586 on 12/28/2016.*

U-4715B

ITS-158

Buncombe County

24. RELOCATE EXISTING SIGN

24.1. DESCRIPTION

Relocate existing signs.

24.2. CONSTRUCTION METHODS

As directed by the Plans, relocate existing signs. Comply with the “Construction Methods” subsection of the “Signs Installed for Signals” section of these Project Special Provisions.

24.3. MEASUREMENT AND PAYMENT

Relocate existing sign will be measured and paid as the actual number of existing signs, regardless of mounting method, relocated and accepted.

Payment will be made under:

| Pay Item | Pay Unit |
|------------------------|-----------------|
| Relocate Existing Sign | Each |

25. EQUIPMENT CABINET FOUNDATIONS

25.1. DESCRIPTION

Furnish and install foundations for base-mounted equipment cabinets and all necessary hardware.

Furnish either poured concrete foundations or preformed cabinet pad foundations and all necessary hardware. Obtain approval of foundation type.

25.2. MATERIALS

Furnish preformed cabinet pad foundation material, equipment, and hardware under this section that is pre-approved on the ITS and Signals QPL.

Provide preformed cabinet pad foundations with 7"(l) x 18"(w) minimum opening for the entrance of conduits. For precast signal cabinet foundations, include steel reinforcement to ensure structural integrity during shipment and placing of item. Include four 3/4" coil thread inserts for lifting. Comply with Article 1077-16 of the *Standard Specifications*.

Furnish cabinet foundations with chamfered top edges. Provide minimum Class B concrete in accordance with Article 1000-4, "Portland Cement Concrete for Structures and Incidental Construction," of the *Standard Specifications*.

Provide standard cabinet foundations in unpaved areas with a minimum pad area that extends 24" from front and back of cabinet base extenders and adapters, and 3" from sides of cabinet base extenders and adapters. For cabinet foundations installed within brick or concrete sidewalks, omit the 24" from the front and rear of the cabinet and provide a foundation that extends 3" from all four sides of the cabinet base extender as shown on the special detail in the Plans.

Furnish Class B Portland cement concrete in accordance with Article 848-2 of the *Standard Specifications*, to replace removed or damaged sections of existing sidewalk and restore locations to preconstruction condition.

Furnish replacement sidewalk pavers where required to restore locations to preconstruction condition that are of the same color, texture, shape, dimensions and materials as the damaged or modified items.

Provide replacement materials for other special pavement treatments or landscaping that are the same materials as the damaged or modified items to restore locations to preconstruction condition.

For repair of concrete sidewalks within historic districts that are removed or damaged by construction, provide concrete tinted to match the appearance of the existing sidewalk.

25.3. CONSTRUCTION METHODS

Comply with Section 825, "Incidental Concrete Construction – General," of the *Standard Specifications*.

Refer to Section 1 of these Project Special Provisions for requirements concerning construction within historic districts.

◆ **Revision No. 1, April 10, 2017 – This document supersedes version originally issued and sealed by J. Todd Brooks, NCPE No. 017586 on 12/28/2016.**

U-4715B**ITS-160****Buncombe County**

Obtain approval for final cabinet foundation locations before pouring concrete base or installing a preformed cabinet base. Locate new cabinets so as not to obstruct sight distance of vehicles turning on red or create any ADA violations or pedestrian conflicts. Maintain 12 inches minimum from service pole to closest point on foundation unless otherwise approved.

Do not install foundations over uncompacted fill or muck. Hand-tamp soil before placing concrete or preformed cabinet base and ensure ground is level.

When using poured concrete foundations, use procedures, equipment, and hardware as follows:

- Use a minimum of four 1/2-inch diameter expanding type anchor bolts to secure cabinet to foundation.
- In unpaved areas, install cabinet foundations a minimum 4 inches above and 4 inches below finished grade. In paved areas, install foundations 1 inch above the paved surface at its highest point and 4 inches below the paved surface at its lowest point.
- Locate external stubbed out conduit at cabinet foundation so conduit is in middle of cabinet. Provide service conduit as the rightmost conduit coming into cabinet. Provide two spare conduits stubbed out; one pointed toward service pole and the other toward direction of lead-in cable. Inscribe identification arrow in foundation indicating direction of spare conduits.
- Ensure that conduits extend 2" to 3" above finished cabinet foundation.
- Give cabinet foundation a broom finish. Seal space between cabinet base and foundation with permanent, flexible, waterproof sealing material.

If using preformed cabinet pad, use loop sealant to seal the conduit stub-outs within the knock-out. Do not use preformed cabinet pad for cabinet foundations located within or adjacent to historic districts.

Restore the disturbed ground surrounding the new cabinet foundation to its original, preconstruction condition as determined and approved by the Engineer.

- For paved areas, replace removed or damaged pavement with in kind materials, matching the elevation, color, texture/finish and general appearance of the surrounding pavement. Refer to Section 1 of these Project Special Provisions for additional requirements concerning sidewalks and curbs in historic districts. Replace concrete sidewalk in whole slabs from joint to joint and comply with Article 848-3 of the *Standard Specifications*. Replace brick pavers using pavers of the same color, texture, shape, dimensions and materials as the damaged or modified items. Place graded stone material to temporarily maintain pedestrian traffic where repairs cannot be performed immediately. Comply with Article 545-4 of the *Standard Specifications*.
- For unpaved areas, backfill excavations with removed material, tamp the backfilled material and rake smooth the top 1½ inches. Finish unpaved areas flush with surrounding natural ground and to match the original contour of the ground. Seed with same type of grass as surrounding area and mulch the newly seeded area. If

◆ **Revision No. 1, April 10, 2017 – This document supersedes version originally issued and sealed by J. Todd Brooks, NCPE No. 017586 on 12/28/2016.**

U-4715B

ITS-161

Buncombe County

unpaved area was not grassed, replace the original ground cover in kind as directed by the Engineer.

Complete repairs to and restoration of all ground (paved and unpaved) disturbed for construction within five consecutive calendar days following initial removal. If the Contractor fails to repair and restore the ground in accordance with these Project Special Provisions within the time frame specified, the Department reserves the right to make the necessary repairs, and all expenses incurred by the Department in making the repairs and restoring the ground will be deducted from payment due the Contractor, plus **\$500 liquidated damages per occasion, per day, or any portion thereof**, until corrected.

25.4. MEASUREMENT AND PAYMENT

Signal cabinet foundation will be measured and paid as the actual number of signal cabinet foundations furnished, installed, and accepted.

4" concrete sidewalk will be measured and paid as the actual square yards of concrete furnished, installed and accepted. Measurement will be made along the surface of the completed and accepted work. Such price includes, but is not limited to, excavating and backfilling, sawing the existing sidewalk, furnishing and placing concrete, and constructing and sealing joints.

No measurement will be made of special finishing, staining and tinting of concrete sidewalk to match the appearance of existing sidewalk as such work will be considered incidental to furnishing and installing 4" concrete sidewalk.

Brick pavers will be measured and paid as the actual square feet of brick pavers furnished, installed and accepted.

No measurement or payment will be made for restoration of the surrounding unpaved ground surfaces in accordance with these Project Special Provisions as such work will be considered incidental to furnishing and installing signal cabinet foundations.

No measurement or payment will be made for furnishing and installing and subsequently removing graded stone material for temporary maintenance pedestrian traffic where a portion of an existing sidewalk has been removed as such work will be considered incidental to furnishing and installing signal cabinet foundations.

Payment will be made under:

| Pay Item | Pay Unit |
|---------------------------|-----------------|
| Signal Cabinet Foundation | Each |
| 4" Concrete Sidewalk | Square Yard |
| Brick Pavers | Square Foot |

◆ **Revision No. 1, April 10, 2017 – This document supersedes version originally issued and sealed by J. Todd Brooks, NCPE No. 017586 on 12/28/2016.**

26. MODIFY CABINET FOUNDATIONS

26.1. DESCRIPTION

Where approved by the Engineer, install conduit entrances into existing foundations in accordance with the Plans and Project Special Provisions.

Modify existing foundations in accordance with the Plans and Project Special Provisions.

26.2. MATERIALS

Comply with the provisions of "Equipment Cabinet Foundations" section of these Project Special Provisions.

26.3. CONSTRUCTION METHODS

A. General

Install new conduit entrances into existing cabinet foundations by core drilling foundations to install additional conduits. New entrances for conduits 1" or less in nominal diameter may be drilled in lieu of core-drilled, subject to the Engineer's approval. Where approved by the Engineer, the foundation may be chipped instead of drilled for conduit entrance.

Ensure that an IMSA certified, or equivalent, Level II traffic qualified signal technician is standing by to provide emergency maintenance services whenever work is being performed on traffic signal controller cabinet foundations. Standby status is defined as being able to arrive, fully equipped, at the work site within 30 minutes ready to provide maintenance services.

B. Install Conduit Entrance into Existing Foundation

Maintain a minimum of 3 inches of cover between new conduit and edge of foundation. Maintain minimum clearances of 1 inch from the flange of the base adapter and 2 inches from existing conduits. Avoid damaging existing conduit, conductors, and anchor bolts. Repair all such damages. Where approved by the Engineer, the foundation may be chipped instead of drilled for conduit entrance. When possible, maintain traffic signal operations while drilling is performed.

Bond new metallic conduit to the cabinet grounding system.

After installation of conduit, place grout to seal around conduit, and return the foundation to normal appearance.

C. Modify Foundation

Enlarge existing cabinet foundations to accommodate the new cabinet and/or to provide a maintenance technician pad.

Excavate the ground around the existing foundation to a depth sufficient to expose a minimum of 4 inches of the foundation below existing grade.

Rough the sides of the existing foundation from the top to a point 4 inches below grade by means of a chisel or other method approved by the Engineer.

Wash the sides of the foundation with water pressurized at 50 psi and thoroughly dry with compressed air.

◆ **Revision No. 1, April 10, 2017 – This document supersedes version originally issued and sealed by J. Todd Brooks, NCPE No. 017586 on 12/28/2016.**

U-4715B

ITS-163

Buncombe County

Drill holes approximately 6 inches deep on 12-inch centers into the existing foundation. Clean holes with compressed air only prior to applying epoxy and installing dowels. Do not clean holes with water or any other liquid. Install #4 dowels and epoxy into place. Provide dowels of the following lengths:

| Foundation Extension | Length of Dowel |
|----------------------|-----------------|
| >16" | 18" |
| >6" and ≤16" | 11" |
| =6" | 8" |

Use concrete to install the maintenance technician pad.

Form the sides of the modified foundation to a minimum depth of 4 inches below grade.

Position forms so that all existing exposed foundation surfaces at or above grade level will be matched.

Apply a coating of approved epoxy bonding agent to all exposed roughened concrete surfaces as recommended by the manufacturer.

As a minimum, enlarge the foundation to the distance specified for new cabinet foundations. Maintenance technician pads should be added to the foundation to provide a minimum work area of 24 inches [length] x 30 inches [width] from both the front and rear doors of the cabinet, unless otherwise directed by the Engineer. Increase the pad enlargement beyond these minimum dimensions to match the width of the existing foundation along the side to which concrete is being added to maintain the rectangular shape of the pad.

Provide a 1-inch chamfer on all new outside edges.

Modify cabinet foundations located within or adjacent to historic districts as shown in the Plans using a concrete mix tinted to match the appearance of the existing concrete foundation being modified.

D. Alternate Methods of Modifying Foundations

Where the Plans call for a new conduit entrance to be installed into an existing cabinet foundation or for the existing foundation to be modified by expanding it, the Contractor may, subject to the approval of the Engineer and at no additional cost to the Department, use one of the following methods in lieu of core-drilling and/or expanding the existing base:

- Remove the existing cabinet foundation and replace it with a new preformed cabinet pad in the same location.
- Overlay the existing cabinet foundation with a new preformed cabinet pad.
- Install a new cabinet foundation adjacent to the existing foundation.

Comply with the construction methods for each method described below.

Do not use alternate methods for modifying foundations within or adjacent to historic districts. Comply with the Plans when modifying foundations within or adjacent to historic districts.

◆ **Revision No. 1, April 10, 2017 – This document supersedes version originally issued and sealed by J. Todd Brooks, NCPE No. 017586 on 12/28/2016.**

1. In Situ Replacement

Carefully remove the existing concrete from around the existing conduit spread, taking care not to damage the conduit stubs or the existing field wiring. Construct additional conduit stub-out(s) where the Plans call for a new conduit entrance in the existing foundation. Once existing concrete has been completely removed and new stub-out(s) has been constructed, immediately set a preformed cabinet pad over the existing conduit spread and new stubout(s). Install preformed cabinet pad in accordance with the manufacturer's instructions. Reinstall existing controller and cabinet or install new controller and cabinet on the new preformed pad. Provide preformed cabinet pads that are listed on the ITS and Signals QPL.

2. Overlay Existing Foundation

Where the top of the existing cabinet foundation is no more than 2 inches above the surrounding ground, overlay the existing foundation by setting a preformed cabinet pad over the existing conduit spread and existing foundation. Level and hand tamp the ground around the existing foundation and install the preformed pad in accordance with the manufacturer's instructions. Furnish and install couplings, nipples, and bushings (PVC or rigid galvanized steel) to extend the existing conduit stub-outs so that the tops of the conduits are 2-3 inches above the top of the preformed pad. Use existing field wiring, splicing and extending the field wiring inside the controller cabinet as needed (refer to Extension of Existing Field Wiring section of these Project Special Provisions). Install new conduit entrance(s) into the existing foundation if necessary.

Immediately reinstall the existing controller and cabinet or install the new controller and cabinet once the preformed pad is set in place.

Backfill around the perimeter of the new pad with topsoil to a point 4 inches below the top surface of the new pad. Gently slope the backfill to tie into the existing ground line with a gradual slope no steeper than 4:1; do not create an abrupt or unsightly mound. Ensure the preformed pad and backfill does not block the flow of runoff or impound water. Hand tamp the new soil and apply grass seed and mulch.

Do not use this method where the top of the existing cabinet foundation is more than 2 inches higher than the surrounding ground, unless the Engineer approves otherwise.

3. Construct New Foundation Adjacent to Existing Foundation

Construct a new cabinet foundation with all necessary hardware adjacent to the existing foundation and rewire the cabinet using one of the following methods:

- Install new risers on adjacent cabinet pole, “pull back” existing field wiring to the top of the existing risers, reinstall existing wiring through the new risers to the new foundation and splice and extend field wiring with gel-filled butt splice connectors in base of new cabinet if necessary.
- Install new risers with terminal splice cabinet on adjacent cabinet pole, “pull back” existing field wiring to the top of the existing risers, and reinstall existing wiring through the new risers to the terminal splice cabinet. Inside the terminal splice cabinet, splice the existing wiring to new conductors from the new base-mounted controller cabinet.

Comply with the “Signal Cabinet Foundations” section and the “Extension of Existing Field Wiring” section of these Project Special Provisions.

◆ **Revision No. 1, April 10, 2017 – This document supersedes version originally issued and sealed by J. Todd Brooks, NCPE No. 017586 on 12/28/2016.**

U-4715B

ITS-165

Buncombe County

E. Ground Surface Restoration

Restore the disturbed ground, both paved and unpaved, surrounding the modified cabinet foundation to its original condition as determined and approved by the Engineer. Comply with all requirements of the “Ground Surface Restoration” subsection of the “Equipment Cabinet Foundation” section of these Project Special Provisions.

26.4. MEASUREMENT AND PAYMENT

Conduit entrance into existing foundation will be measured as the actual number of conduit entrances drilled into existing cabinet foundations furnished, installed and accepted. As approved by the Engineer, law enforcement provided for directing traffic while a signal is inoperable during construction of conduit entrance into existing foundation will be measured and paid for separately in accordance with the “Temporary Traffic Control” section of these Project Special Provisions.

Modify foundation for controller cabinet will be measured as the actual number of existing cabinet foundations modified and accepted.

Alternate methods for adding conduit entrances to and modifying existing cabinet foundations will be measured and paid as *conduit entrance into existing foundation* and/or *modify foundation for controller cabinet*, as specified in the Plans for the given location. Such payment will be full compensation for all work required to add the conduit entrance and/or modify the cabinet foundation using one of the alternate methods described above. No separate measurement will be made of preformed cabinet pads, removal of existing foundations or splicing and extending existing field wiring required due to the use of an alternate method for adding a conduit entrance or for modifying an existing cabinet foundation.

Restoration of the surrounding ground surfaces, paved and unpaved, will be measured and paid for in accordance with the “Equipment Cabinet Foundations” section of these Project Special Provisions.

Payment will be made under:

| Pay Item | Pay Unit |
|---|-----------------|
| Conduit Entrance into Existing Foundation | Each |
| Modify Foundation for Controller Cabinet | Each |

◆ **Revision No. 1, April 10, 2017 – This document supersedes version originally issued and sealed by J. Todd Brooks, NCPE No. 017586 on 12/28/2016.**

27. CONTROLLERS WITH CABINETS

27.1. DESCRIPTION

Furnish and install controllers with cabinets and all necessary hardware. Furnish all pole or foundation mounting hardware, detector sensor cards, one Corbin Number 2 cabinet key, one police panel key, conflict monitors, surge protection, grounding systems, AC/DC isolator cards, auxiliary files (where required) and all necessary hardware. Install updates of local controller and operating system software.

27.2. MATERIALS - GENERAL

Furnish material, equipment, and hardware under this section that is pre-approved on the ITS and Signals QPL.

27.3. MATERIALS – TYPE 2070E CONTROLLERS

Conform to CALTRANS *Transportation Electrical Equipment Specifications* (TEES) (dated March 12, 2009, plus Errata 1 dated January 21, 2010) except as required herein.

Furnish Model 2070E controllers. Ensure that removal of the CPU module from the controller will place the intersection into flash.

The Department will provide local controller software at the beginning of the burning-in period. **The Contractor shall give 5 working days notice before needing software.** Program software provided by the Department. The Department will provide updates to the local controller software for installation by the Contractor up through final acceptance of the project.

Provide Model 2070E controllers with the latest version of OS9 operating system software and device drivers, composed of the unit chassis and at a minimum the following modules and assemblies:

- MODEL 2070-1E, CPU Module, Single Board, with 8Mb Datakey (blue in color)
- MODEL 2070-2A or approved MODEL 2070-2E, Field I/O Module (FI/O)
 Note: Configure the Field I/O Module to disable both the External WDT Shunt/Toggle Switch and SP3 (SP3 active indicator is “off”)
- MODEL 2070-3B, Front Panel Module (FP), Display B (8x40)
- MODEL 2070-4, Power Supply Module, 10 AMP
- MODEL 2070-7A, Async Serial Com Module (9-pin RS-232)

Provide all updates to the OS9 operating system software released up through final acceptance of the project at no additional cost to the Department.

Provide Model 2070E controllers that are capable of properly running the Department’s OASIS local controller software and that are capable of operating properly within an Ethernet communications system.

27.4. MATERIALS – GENERAL CABINETS

Provide a moisture resistant coating on all circuit boards.

Provide one 20 mm diameter radial lead UL-recognized metal oxide varistor (MOV) between each load switch field terminal and equipment ground. Electrical performance is outlined below.

◆ **Revision No. 1, April 10, 2017 - This document supersedes version originally issued and sealed by J. Todd Brooks, NCPE No. 017586 on 12/28/2016**

U-4715B

ITS-167

Buncombe County

| PROPERTIES OF MOV SURGE PROTECTOR | |
|--|--------------------------|
| Maximum Continuous Applied Voltage at 185° F | 150 VAC (RMS) 200 VDC |
| Maximum Peak 8x20µs Current at 185° F | 6500 A |
| Maximum Energy Rating at 185° F | 80 J |
| Voltage Range 1 mA DC Test at 77° F | 212-268 V |
| Max. Clamping Voltage 8x20µs, 100A at 77° F | 395 V |
| Typical Capacitance (1 MHz) at 77° F | 1600 pF |

Provide a power line surge protector that is a two-stage device that will allow connection of the radio frequency interference filter between the stages of the device. Ensure that a maximum continuous current is at least 10A at 120V. Ensure that the device can withstand a minimum of 20 peak surge current occurrences at 20,000A for an 8x20 microsecond waveform. Provide a maximum clamp voltage of 395V at 20,000A with a nominal series inductance of 200µh. Ensure that the voltage does not exceed 395V. Provide devices that comply with the following:

| Frequency (Hz) | Minimum Insertion Loss (dB) |
|----------------|-----------------------------|
| 60 | 0 |
| 10,000 | 30 |
| 50,000 | 55 |
| 100,000 | 50 |
| 500,000 | 50 |
| 2,000,000 | 60 |
| 5,000,000 | 40 |
| 10,000,000 | 20 |
| 20,000,000 | 25 |

27.5. MATERIALS – TYPE 170E CABINETS

A. Type 170 E Cabinets General

Conform to the city of Los Angeles' Specification No. 54-053-08, *Traffic Signal Cabinet Assembly Specification* (dated July 2008), except as required herein.

Furnish model 336S pole-mounted and base-mounted cabinets configured for 8 vehicle phases, 4 pedestrian phases, and 6 overlaps. Do not reassign load switches to accommodate overlaps unless shown on electrical details. Provide 336S pole-mounted and base-mounted cabinets that are 46" high with 40" high internal rack assemblies.

Furnish model 332 base mounted cabinets configured for 8 vehicle phases, 4 pedestrian phases, and 6 overlaps. When overlaps are required, provide auxiliary output files for the overlaps. Do not reassign load switches to accommodate overlaps unless shown on electrical details.

Provide model 200 load switches, model 222 loop detector sensors, model 252 AC isolators, and model 242 DC isolators according to the electrical details. As a minimum, provide one (1) model 2018 conflict monitor, one (1) model 206L power supply unit, two (2) model 204 flashers,

◆ **Revision No. 1, April 10, 2017 - This document supersedes version originally issued and sealed by J. Todd Brooks, NCPE No. 017586 on 12/28/2016**

one (1) DC isolator (located in slot I14), and four (4) model 430 flash transfer relays (provide seven (7) model 430 flash transfer relays if auxiliary output file is installed) with each cabinet.

B. Special Coating for Cabinets

For certain locations within local historic districts in Asheville as designated in the Plans, provide cabinets with a special medium gray powder-coated finish and anti-graffiti coating in accordance with the “Special Coating for Cabinets” section of these Project Special Provisions. The locations include:

- Montford Avenue at Cullowhee Street (COA-411)
- Montford Avenue at Chestnut Street (COA-407)
- Charlotte Street at Hillside Street (COA-009)
- Victoria Road at Fernihurst Drive (COA-016)
- McDowell Street at Lodge Street (13-0389)
- Hendersonville Road at Vanderbilt Road/All Souls Crescent (13-0241)
- Hendersonville Road at Lodge Street (13-0242)

C. Type 170 E Cabinet Electrical Requirements

Provide a cabinet assembly designed to ensure that upon leaving any cabinet switch or conflict monitor initiated flashing operation, the controller starts up in the programmed start up phases and start up interval.

Furnish two sets of non-fading cabinet wiring diagrams and schematics in a paper envelope or container and placed in the cabinet drawer.

All AC+ power is subject to radio frequency signal suppression.

Provide surge suppression in the cabinet for each type of cabinet device. Provide surge protection for the full capacity of the cabinet input file. Provide surge suppression devices that operate properly over a temperature range of -40° F to +185° F. Ensure the surge suppression devices provide both common and differential modes of protection.

Provide a pluggable power line surge protector that is installed on the back of the PDA (power distribution assembly) chassis to filter and absorb power line noise and switching transients. Ensure the device incorporates LEDs for failure indication and provides a dry relay contact closure for the purpose of remote sensing. Ensure the device meets the following specifications:

| | |
|--|----------------------|
| Peak Surge Current (Single pulse, 8x20µs)..... | 20,000A |
| Occurrences (8x20µs waveform)..... | 10 minimum @ 20,000A |
| Maximum Clamp Voltage..... | 395VAC |
| Operating Current..... | 15 amps |
| Response Time..... | < 5 nanoseconds |

U-4715B**ITS-169****Buncombe County**

Provide a loop surge suppressor for each set of loop terminals in the cabinet. Ensure the device meets the following specifications:

| | |
|--|-----------------|
| Peak Surge Current (6 times, 8x20 μ s) | |
| (Differential Mode)..... | 400A |
| (Common Mode)..... | 1,000A |
| Occurrences (8x20 μ s waveform)..... | 500 min @ 200A |
| Maximum Clamp Voltage | |
| (Differential Mode @400A)..... | 35V |
| (Common Mode @1,000A)..... | 35V |
| Response Time..... | < 5 nanoseconds |
| Maximum Capacitance..... | 35 pF |

Provide a data communications surge suppressor for each communications line entering or leaving the cabinet. Ensure the device meets the following specifications:

| | |
|--|-------------------------------|
| Peak Surge Current (Single pulse, 8x20 μ s)..... | 10,000A |
| Occurrences (8x20 μ s waveform)..... | 100 min @ 2,000A |
| Maximum Clamp Voltage..... | Rated for equipment protected |
| Response Time..... | < 1 nanosecond |
| Maximum Capacitance..... | 1,500 pF |
| Maximum Series Resistance..... | 15 Ω |

Provide a DC signal surge suppressor for each DC input channel in the cabinet. Ensure the device meets the following specifications:

| | |
|--|----------------|
| Peak Surge Current (Single pulse, 8x20 μ s)..... | 10,000A |
| Occurrences (8x20 μ s waveform)..... | 100 @ 2,000A |
| Maximum Clamp Voltage..... | 30V |
| Response Time..... | < 1 nanosecond |

Provide a 120 VAC signal surge suppressor for each AC+ interconnect signal input. Ensure the device meets the following specifications:

| | |
|--|-----------------------|
| Peak Surge Current (Single pulse, 8x20 μ s)..... | 20,000A |
| Maximum Clamp Voltage..... | 350VAC |
| Response Time..... | < 200 nanoseconds |
| Discharge Voltage..... | <200 Volts @ 1,000A |
| Insulation Resistance..... | \geq 100 M Ω |

Provide conductors for surge protection wiring that are of sufficient size (ampacity) to withstand maximum overcurrents which could occur before protective device thresholds are attained and current flow is interrupted.

◆ **Revision No. 1, April 10, 2017 - This document supersedes version originally issued and sealed by J. Todd Brooks, NCPE No. 017586 on 12/28/2016**

U-4715B**ITS-170****Buncombe County**

If additional surge protected power outlets are needed to accommodate fiber transceivers, modems, etc., install a UL listed, industrial, heavy-duty type power outlet strip with a minimum rating of 15 A / 125 VAC, 60 Hz. Provide a strip that has a minimum of 3 grounded outlets. Ensure the power outlet strip plugs into one of the controller unit receptacles located on the rear of the PDA. Ensure power outlet strip is mounted securely; provide strain relief if necessary.

Provide a door switch in the front and a door switch in the rear of the cabinet that will provide the controller unit with a Door Ajar alarm when either the front or the rear door is open. Ensure the door switches apply DC ground to the Input File when either the front door or the rear door is open.

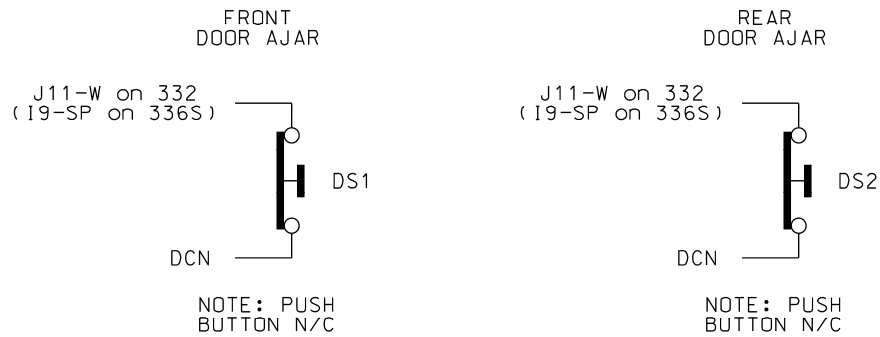

Furnish a fluorescent fixture in the rear across the top of the cabinet and another fluorescent fixture in the front across the top of the cabinet at a minimum. Ensure that the fixtures provide sufficient light to illuminate all terminals, labels, switches, and devices in the cabinet. Conveniently locate the fixtures so as not to interfere with a technician's ability to perform work on any devices or terminals in the cabinet. Provide a protective diffuser to cover exposed bulbs. Install 16 watt T-4 lamps in the fluorescent fixtures. Provide a door switch to provide power to each fixture when the respective door is open. Wire the fluorescent fixtures to the 15 amp ECB (equipment circuit breaker).

U-4715B

ITS-171

Buncombe County

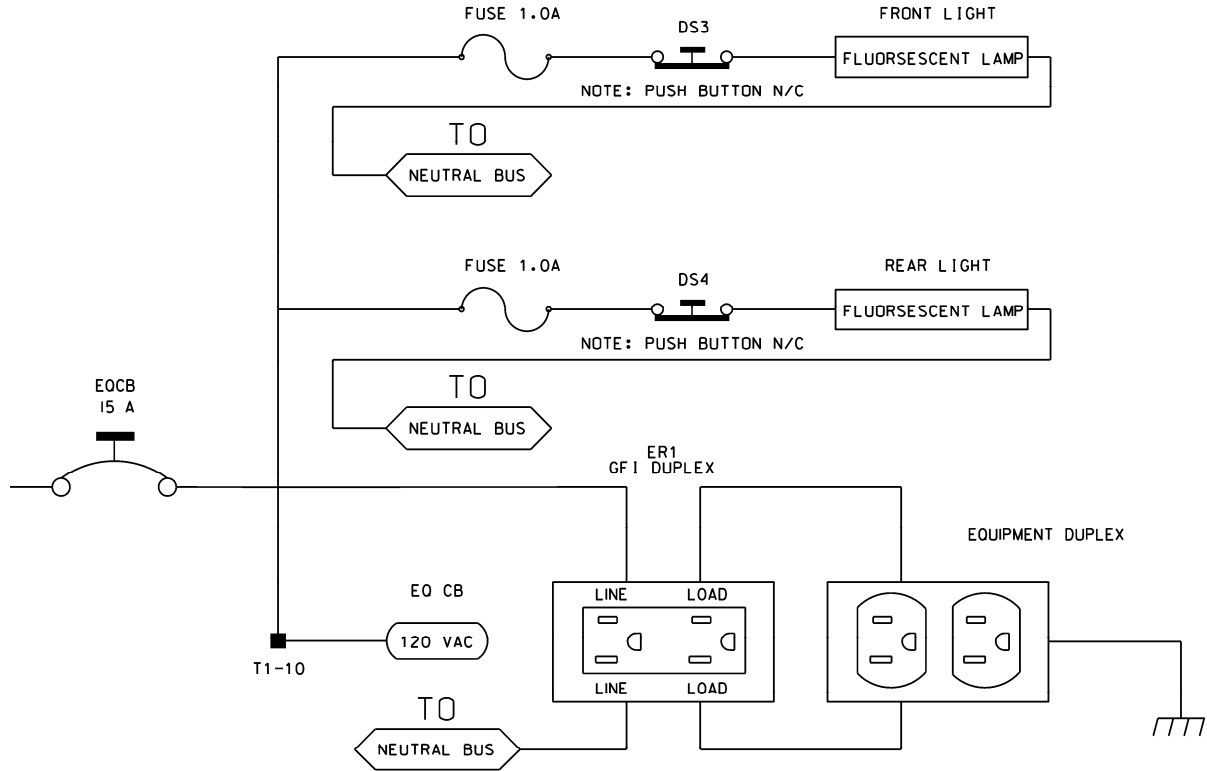

Furnish a police panel with a police panel door. For model 336S cabinets, mount the police panel on the rear door. Ensure that the police panel door permits access to the police panel when the main door is closed. Ensure that no rainwater can enter the cabinet even with the police panel door open. Provide a police panel door hinged on the right side as viewed from the front. Provide a police panel door lock that is keyed to a standard police/fire call box key. In addition to the requirements of LA Specification No. 54-053-08, provide the police panel with a toggle switch connected to switch the intersection operation between normal stop-and-go operation (AUTO) and manual operation (MANUAL). Ensure that manual control can be implemented using inputs and software such that the controller provides full programmed clearance times for the yellow clearance and red clearance for each phase while under manual control.

Provide a 1/4-inch locking phone jack in the police panel for a hand control to manually control the intersection. Provide sufficient room in the police panel for storage of a hand control and cord.

Ensure the 336S cabinet Input Files are wired as follows:

◆ **Revision No. 1, April 10, 2017 - This document supersedes version originally issued and sealed by J. Todd Brooks, NCPE No. 017586 on 12/28/2016**

U-4715B

ITS-172

Buncombe County

| 336 Cabinet Port-Bit/C-1 Pin Assignment | | | | | | | | | | | | | | |
|--|-----------|-----------|-----------|-----------|-----------|-----------|-----------|-----------|-----------|-----------|-----------|-----------|-----------|-----------|
| Slot # | 1 | 2 | 3 | 4 | 5 | 6 | 7 | 8 | 9 | 10 | 11 | 12 | 13 | 14 |
| C-1 (Spares) | 59 | 60 | 61 | 62 | 63 | 64 | 65 | 66 | 75 | 76 | 77 | 78 | 79 | 80 |
| Port C-1 | 3-2 56 | 1-1 39 | 3-4 58 | 1-3 41 | 3-1 55 | 1-2 40 | 3-3 57 | 1-4 42 | 2-5 51 | 5-5 71 | 5-6 72 | 5-1 67 | 5-2 68 | 6-7 81 |
| Port C-1 | 2-1 47 | 1-5 43 | 2-3 49 | 1-7 45 | 2-2 48 | 1-6 44 | 2-4 50 | 1-8 46 | 2-6 52 | 5-7 73 | 5-8 74 | 5-3 69 | 5-4 70 | 6-8 82 |

For model 332 base mounted cabinets, ensure terminals J14-E and J14-K are wired together on the rear of the Input File. Connect TB9-12 (J14 Common) on the Input Panel to T1-2 (AC-) on the rear of the PDA.

Provide detector test switches mounted at the top of the cabinet rack or other convenient location which may be used to place a call on each of eight phases based on the chart below. Provide three positions for each switch: On (place call), Off (normal detector operation), and Momentary On (place momentary call and return to normal detector operation after switch is released). Ensure that the switches are located such that the technician can read the controller display and observe the intersection.

Connect detector test switches for cabinets as follows:

| 336 Cabinet | | 332 Cabinet | |
|------------------------|-----------|------------------------|-----------|
| Detector Call Switches | Terminals | Detector Call Switches | Terminals |
| Phase 1 | I1-F | Phase 1 | I1-W |
| Phase 2 | I2-F | Phase 2 | I4-W |
| Phase 3 | I3-F | Phase 3 | I5-W |
| Phase 4 | I4-F | Phase 4 | I8-W |
| Phase 5 | I5-F | Phase 5 | J1-W |
| Phase 6 | I6-F | Phase 6 | J4-W |
| Phase 7 | I7-F | Phase 7 | J5-W |
| Phase 8 | I8-F | Phase 8 | J8-W |

Provide the PCB 28/56 connector for the conflict monitor unit (CMU) with 28 independent contacts per side, dual-sided with 0.156 inch contact centers. Provide the PCB 28/56 connector contacts with solder eyelet terminations. Ensure all connections to the PCB 28/56 connector are soldered to the solder eyelet terminations.

Ensure that all cabinets have the CMU connector wired according to the 332 cabinet connector pin assignments (include all wires for auxiliary output file connection). Wire pins 13, 16, R, and U of the CMU connector to a separate 4 pin plug, P1, as shown below. Provide a second plug, P2, which will mate with P1 and is wired to the auxiliary output file as shown below. Provide an additional plug, P3, which will mate with P1 and is wired to the pedestrian yellow circuits as shown below. When no auxiliary output file is installed in the cabinet, provide wires for the green and yellow inputs for channels 11, 12, 17, and 18, the red inputs for channels

◆ **Revision No. 1, April 10, 2017 - This document supersedes version originally issued and sealed by J. Todd Brooks, NCPE No. 017586 on 12/28/2016**

U-4715B**ITS-173****Buncombe County**

17 and 18, and the wires for the P2 plug. Terminate the two-foot wires with ring type lugs, insulated, and bundled for optional use.

| PIN | P1 | | P2 | | P3 | |
|-----|----------|---------|----------|---------|----------|---------|
| | FUNCTION | CONN TO | FUNCTION | CONN TO | FUNCTION | CONN TO |
| 1 | CH-9G | CMU-13 | OLA-GRN | A123 | 2P-YEL | 114 |
| 2 | CH-9Y | CMU-16 | OLA-YEL | A122 | 4P-YEL | 105 |
| 3 | CH-10G | CMU-R | OLB-GRN | A126 | 6P-YEL | 120 |
| 4 | CH-10Y | CMU-U | OLB-YEL | A125 | 8P-YEL | 111 |

Do not provide the P20 terminal assembly (red monitor board) or red interface ribbon cable as specified in the LA Specification No. 54-053-08.

Provide a P20 connector that mates with and is compatible with the red interface connector mounted on the front of the conflict monitor. Ensure that the P20 connector and the red interface connector on the conflict monitor are center polarized to ensure proper connection. Ensure that removal of the P20 connector will cause the conflict monitor to recognize a latching fault condition and place the cabinet into flashing operation.

Wire the P20 connector to the output file and auxiliary output file using 22 AWG stranded wires. Ensure the length of these wires is a minimum of 42 inches. Provide a durable braided sleeve around the wires to organize and protect the wires.

Wire the P20 connector to the traffic signal red displays to provide inputs to the conflict monitor as shown below. Ensure the pedestrian Don't Walk circuits are wired to channels 13 through 16 of the P20 connector. When no auxiliary output file is installed in the cabinet, provide wires for channels 9 through 12 reds. Provide a wire for special function 1. Terminate the unused wires with ring type lugs, insulated, and bundled for optional use.

| P20 Connector | | | | | |
|---------------|----------------|---------|-----|-----------------|---------|
| PIN | FUNCTION | CONN TO | PIN | FUNCTION | CONN TO |
| 1 | Channel 15 Red | 119 | 11 | Channel 16 Red | 110 |
| 2 | Channel 14 Red | 104 | 12 | Chassis GND | 01-9 |
| 3 | Channel 13 Red | 113 | 13 | N/C | |
| 4 | Channel 12 Red | AUX 101 | 14 | Spec Function 1 | |
| 5 | Channel 10 Red | AUX 124 | 15 | Channel 11 Red | AUX 114 |
| 6 | Channel 9 Red | AUX 121 | 16 | Channel 8 Red | 107 |
| 7 | Channel 7 Red | 122 | 17 | Channel 6 Red | 134 |
| 8 | Channel 5 Red | 131 | 18 | Channel 4 Red | 101 |
| 9 | Channel 3 Red | 116 | 19 | Channel 2 Red | 128 |
| 10 | Channel 1 Red | 125 | 20 | Red Enable | 01-14 |

Do not wire pin 12 of the load switch sockets.

Ensure the controller unit outputs to the auxiliary output file are pre-wired to the C5 connector. When no auxiliary output file is installed in the cabinet, connect the C5 connector to a storage socket located on the Input Panel or on the rear of the PDA.

◆ **Revision No. 1, April 10, 2017 - This document supersedes version originally issued and sealed by J. Todd Brooks, NCPE No. 017586 on 12/28/2016**

U-4715B

ITS-175

Buncombe County

| ACCEPTABLE LOAD RESISTOR VALUES | |
|---------------------------------|-----------|
| VALUE (ohms) | WATTAGE |
| 1.5K – 1.9 K | 25W (min) |
| 2.0K – 3.0K | 10W (min) |

Provide Model 200 load switches, Model 204 flashers, Model 242 DC isolators, Model 252 AC isolators, and Model 206L power supply units that conform to CALTRANS' "Transportation Electrical Equipment Specifications" dated March 12, 2009 with Erratum 1.

D. Type 170 E Cabinet Physical Requirements

Do not mold, cast, or scribe the name "City of Los Angeles" on the outside of the cabinet door as specified in LA Specification No. 54-053-08. Do not provide a Communications Terminal Panel as specified in LA Specification No. 54-053-08. Do not provide terminal block TBB on the Service Panel. Do not provide Cabinet Verification Test Program software or associated test jigs as specified in LA Specification No. 54-053-08.

Furnish unpainted, natural, aluminum cabinet shells for all locations except those identified in the "Special Coatings for Cabinets" subsection above to have custom finish applied to the cabinets. Ensure that all non-aluminum hardware on the cabinet is stainless steel or a Department approved non-corrosive alternate.

Ensure the lifting eyes, gasket channels, police panel, and all supports welded to the enclosure and doors are fabricated from 0.125 inch minimum thickness aluminum sheet and meet the same standards as the cabinet and doors.

Provide front and rear doors with latching handles that allow padlocking in the closed position. Furnish 0.75 inch minimum diameter stainless steel handles with a minimum 0.5 inch shank. Place the padlocking attachment at 4.0 inches from the handle shank center to clear the lock and key. Provide an additional 4.0 inches minimum gripping length.

Provide Corbin #2 locks on the front and rear doors. Provide one (1) Corbin #2 and one (1) police master key with each cabinet. Ensure main door locks allow removal of keys in the locked position only.

Provide a surge protection panel with 16 loop surge protection devices and designed to allow sufficient free space for wire connection/disconnection and surge protection device replacement. For model 332 cabinets, provide an additional 20 loop surge protection devices. Provide an additional two AC+ interconnect surge devices to protect one slot and eight DC surge protection devices to protect four slots. Provide no protection devices on slot I14.

For 336S pole-mounted and 336S base-mounted cabinets, mount surge protection devices for the AC+ interconnect inputs, inductive loop detector inputs, and low voltage DC inputs on a swing down panel assembly fabricated from sturdy aluminum. Attach the swing down panel to the bottom rear cabinet rack assembly using thumb screws. Ensure the swing down panel allows for easy removal of the input file without removing the surge protection panel assembly or its parts. Have the surge protection devices mounted horizontally on the panel and soldered to the feed through terminals of four 14 position terminal blocks with #8 screws mounted on the other side. Ensure the top row of terminals is connected to the upper slots and the bottom row of terminals is connected to the bottom slots. Provide a 15 position copper equipment ground bus attached to the field terminal side (outside) of the swing down panel for termination of loop lead-

◆ **Revision No. 1, April 10, 2017 - This document supersedes version originally issued and sealed by J. Todd Brooks, NCPE No. 017586 on 12/28/2016**

U-4715B

ITS-177

Buncombe County

ground bus attached to the surge protection panel. Wire the terminals to the rear of a standard input file using spade lugs for input file protection.

Provide permanent labels that indicate the slot and the pins connected to each terminal that may be viewed from the rear cabinet door. Label and orient terminals so that each pair of inputs is next to each other. Indicate on the labeling the input file (I or J), the slot number (1-14) and the terminal pins of the input slots (either D & E for upper or J & K for lower).

Provide a minimum 14 x 16 inch pull out, hinged top shelf located immediately below controller mounting section of the cabinet. Ensure the shelf is designed to fully expose the table surface outside the controller at a height approximately even with the bottom of the controller. Ensure the shelf has a storage bin interior which is a minimum of 1 inch deep and approximately the same dimensions as the shelf. Provide an access to the storage area by lifting the hinged top of the shelf. Fabricate the shelf and slide from aluminum or stainless steel and ensure the assembly can support the 2070E controller plus 15 pounds of additional weight. Ensure shelf has a locking mechanism to secure it in the fully extended position and does not inhibit the removal of the 2070E controller or removal of cards inside the controller when fully extended. Provide a locking mechanism that is easily released when the shelf is to be returned to its non-use position directly under the controller.

27.6. MATERIALS – MODEL 2018 ENHANCED CONFLICT MONITOR

Furnish Model 2018 Enhanced Conflict Monitors that provide monitoring of 18 channels. Ensure each channel consists of a green, yellow, and red field signal input. Ensure that the conflict monitor meets or exceeds CALTRANS *Transportation Electrical Equipment Specifications* dated March 12, 2009 with Erratum 1 (hereafter referred to as CALTRANS' 2009 TEES) for a model 210 monitor unit and other requirements stated in this specification.

Ensure the conflict monitor is provided with an 18 channel conflict programming card. Pin EE and Pin T of the programming card shall be connected together. Pin 16 of the conflict programming card shall be floating. Ensure that the absence of the conflict programming card will cause the conflict monitor to trigger (enter into fault mode), and remain in the triggered state until the programming card is properly inserted and the conflict monitor is reset.

Provide a conflict monitor that incorporates LED indicators into the front panel to dynamically display the status of the monitor under normal conditions and to provide a comprehensive review of field inputs with monitor status under fault conditions. Ensure that the monitor indicates the channels that were active during a conflict condition and the channels that experienced a failure for all other per channel fault conditions detected. Ensure that these indications and the status of each channel are retained until the Conflict Monitor is reset. Furnish LED indicators for the following:

- AC Power (Green LED indicator)
- VDC Failed (Red LED indicator)
- WDT Error (Red LED indicator)
- Conflict (Red LED indicator)
- Red Fail (Red LED indicator)
- Dual Indication (Red LED indicator)
- Yellow/Clearance Failure (Red LED indicator)

◆ **Revision No. 1, April 10, 2017 - This document supersedes version originally issued and sealed by J. Todd Brooks, NCPE No. 017586 on 12/28/2016**

U-4715B**ITS-178****Buncombe County**

- PCA/PC Ajar (Red LED indicator)
- Monitor Fail/Diagnostic Failure (Red LED indicator)
- 54 Channel Status Indicators (1 Red, 1 Yellow, and 1 Green LED indicator for each of the 18 channels)

Provide a switch to set the Red Fail fault timing. Ensure that when the switch is in the ON position the Red Fail fault timing value is set to 1350 +/- 150ms (2018 mode). Ensure that when the switch is in the OFF position the Red Fail fault timing value is set to 850 +/- 150ms (210 mode).

Provide a switch to set the Watchdog fault timing. Ensure that when the switch is in the ON position the Watchdog fault timing value is set to 1.0 +/- 0.1s (2018 mode). Ensure that when the switch is in the OFF position the Watchdog fault timing value is set to 1.5 +/- 0.1s (210 mode).

Provide a jumper or switch to set the AC line brown-out levels. Ensure that when the jumper is present or the switch is in the ON position the AC line dropout voltage threshold is 98 +/- 2 Vrms, the AC line restore voltage threshold is 103 +/- 2 Vrms, and the AC line brown-out timing value is set to 400 +/- 50ms (2018 mode). Ensure that when the jumper is not present or the switch is in the OFF position the AC line dropout voltage threshold is 92 +/- 2 Vrms, the AC line restore voltage threshold is 98 +/- 2 Vrms, and the AC line brown-out timing value is set to 80 +/- 17ms (210 mode).

Provide a jumper or switch that will enable and disable the Watchdog Latch function. Ensure that when the jumper is not present or the switch is in the OFF position the Watchdog Latch function is disabled. In this mode of operation, a Watchdog fault will be reset following a power loss, brownout, or power interruption. Ensure that when the jumper is present or the switch is in the ON position the Watchdog Latch function is enabled. In this mode of operation, a Watchdog fault will be retained until a Reset command is issued.

Provide a jumper that will reverse the active polarity for pin #EE (output relay common). Ensure that when the jumper is not present pin #EE (output relay common) will be considered 'Active' at a voltage greater than 70 Vrms and 'Not Active' at a voltage less than 50 Vrms (Caltrans mode). Ensure that when the jumper is present pin #EE (output relay common) will be considered 'Active' at a voltage less than 50 Vrms and 'Not Active' at a voltage greater than 70 Vrms (Failsafe mode).

In addition to the connectors required by CALTRANS' 2009 TEES, provide the conflict monitor with a red interface connector mounted on the front of the monitor. Ensure the connector is 20-pin, right angle, center polarized, male connector with latching clip locks and polarizing keys. Ensure the right angle solder tails are designed for 0.062" thick printed circuit board. Keying of the connector shall be between pins 3 and 5, and between 17 and 19. Ensure the connector has two rows of pins with the odd numbered pins are on one row and the even pins on the other row. Ensure the connector pin row spacing is 0.10" and pitch is 0.10". Ensure the mating length of the connector pins is 0.24". Ensure the pins are finished with gold plating 30μ" thick.

◆ **Revision No. 1, April 10, 2017 - This document supersedes version originally issued and sealed by J. Todd Brooks, NCPE No. 017586 on 12/28/2016**

U-4715B

ITS-179

Buncombe County

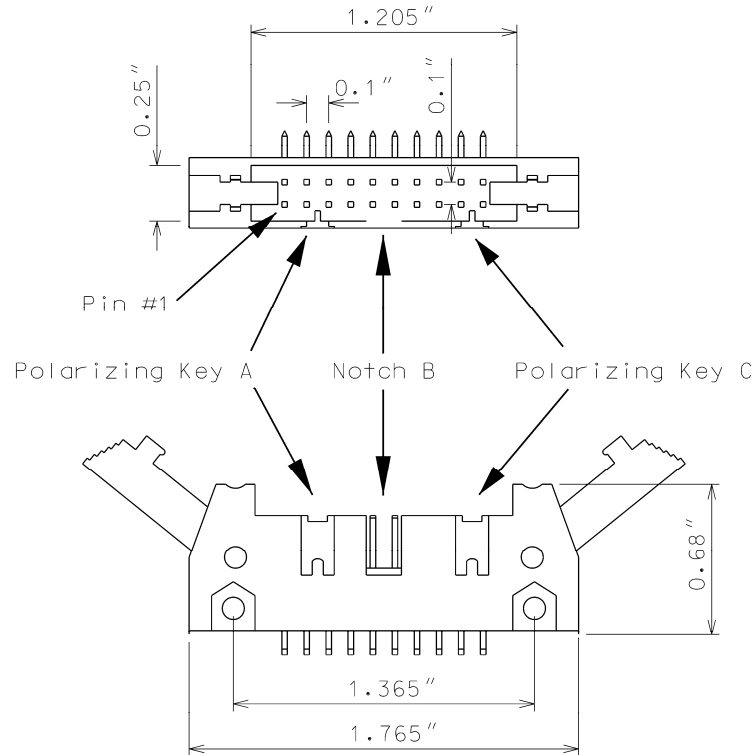

Ensure the red interface connector pins on the monitor have the following functions:

| Pin # | Function | Pin # | Function |
|-------|----------------|-------|--------------------|
| 1 | Channel 15 Red | 2 | Channel 16 Red |
| 3 | Channel 14 Red | 4 | Chassis Ground |
| 5 | Channel 13 Red | 6 | Special Function 2 |
| 7 | Channel 12 Red | 8 | Special Function 1 |
| 9 | Channel 10 Red | 10 | Channel 11 Red |
| 11 | Channel 9 Red | 12 | Channel 8 Red |
| 13 | Channel 7 Red | 14 | Channel 6 Red |
| 15 | Channel 5 Red | 16 | Channel 4 Red |
| 17 | Channel 3 Red | 18 | Channel 2 Red |
| 19 | Channel 1 Red | 20 | Red Enable |

Ensure that the removal of the P20 cable will cause the conflict monitor to recognize a latching fault condition and place the cabinet into flashing operation.

Provide Special Function 1 and Special Function 2 inputs to the unit which shall disable only Red Fail Monitoring when either input is sensed active. A Special Function input shall be sensed active when the input voltage exceeds 70 Vrms with a minimum duration of 550 ms. A Special Function input shall be sensed not active when the input voltage is less than 50 Vrms or the duration is less than 250 ms. A Special Function input is undefined by these specifications and may or may not be sensed active when the input voltage is between 50 Vrms and 70 Vrms or the duration is between 250 ms and 550 ms.

◆ **Revision No. 1, April 10, 2017 - This document supersedes version originally issued and sealed by J. Todd Brooks, NCPE No. 017586 on 12/28/2016**

U-4715B

ITS-180

Buncombe County

Ensure the conflict monitor recognizes field signal inputs for each channel that meet the following requirements:

- consider a Red input greater than 70 Vrms and with a duration of at least 500 ms as an “on” condition;
- consider a Red input less than 50 Vrms or with a duration of less than 200 ms as an “off” condition (no valid signal);
- consider a Red input between 50 Vrms and 70 Vrms or with a duration between 200 ms and 500 ms to be undefined by these specifications;
- consider a Green or Yellow input greater than 25 Vrms and with a duration of at least 500 ms as an “on” condition;
- consider a Green or Yellow input less than 15 Vrms or with a duration of less than 200 ms as an “off” condition; and
- consider a Green or Yellow input between 15 Vrms and 25 Vrms or with a duration between 200 ms and 500 ms to be undefined by these specifications.

Provide a conflict monitor that recognizes the faults specified by CALTRANS’ 2009 TEES and the following additional faults. Ensure the conflict monitor will trigger upon detection of a fault and will remain in the triggered (in fault mode) state until the unit is reset at the front panel or through the external remote reset input for the following failures:

1. **Red Monitoring or Absence of Any Indication (Red Failure):** A condition in which no “on” voltage signal is detected on any of the green, yellow, or red inputs to a given monitor channel. If a signal is not detected on at least one input (R, Y, or G) of a conflict monitor channel for a period greater than 1000 ms when used with a 170 controller and 1500 ms when used with a 2070E controller, ensure monitor will trigger and put the intersection into flash. If the absence of any indication condition lasts less than 700 ms when used with a 170 controller and 1200 ms when used with a 2070E controller, ensure conflict monitor will not trigger. Red fail monitoring shall be enabled on a per channel basis by the use of switches located on the conflict monitor. Have red monitoring occur when all of the following input conditions are in effect:
 - a) Red Enable input to monitor is active (Red Enable voltages are “on” at greater than 70 Vrms, off at less than 50 Vrms, undefined between 50 and 70 Vrms), and
 - b) Neither Special Function 1 nor Special Function 2 inputs are active.
 - c) Pin #EE (output relay common) is not active.
2. **Short/Missing Yellow Indication Error (Sequence Error):** Yellow indication following a green is missing or shorter than 2.7 seconds (with ± 0.1 -second accuracy). If a channel fails to detect an “on” signal at the Yellow input for a minimum of 2.7 seconds (± 0.1 second) following the detection of an “on” signal at a Green input for that channel, ensure that the monitor triggers and generates a clearance/short yellow error fault indication. Short/missing yellow (clearance) monitoring shall be enabled on a per channel bases by the use of switches located on the conflict monitor. This fault shall not occur when the channel is programmed for Yellow Inhibit, when the Red Enable signal is inactive or pin #EE (output relay common) is active.
3. **Dual Indications on the Same Channel:** In this condition, more than one indication (R,Y,G) is detected as “on” at the same time on the same channel. If dual indications are detected for a period greater than 500 ms, ensure that the conflict monitor triggers and

◆ **Revision No. 1, April 10, 2017 - This document supersedes version originally issued and sealed by J. Todd Brooks, NCPE No. 017586 on 12/28/2016**

displays the proper failure indication (Dual Ind fault). If this condition is detected for less than 200 ms, ensure that the monitor does not trigger. G-Y-R dual indication monitoring shall be enabled on a per channel basis by use of switches located on the conflict monitor. G-Y dual indication monitoring shall be enabled for all channels by use of a switch located on the conflict monitor. This fault shall not occur when the Red Enable signal is inactive or pin #EE (output relay common) is active.

4. **Configuration Settings Change:** The configuration settings are comprised of (as a minimum) the permissive diode matrix, dual indication switches, yellow disable jumpers, any option switches, any option jumpers, and the Watchdog Enable switch. Ensure the conflict monitor compares the current configuration settings with the previous stored configuration settings on power-up, on reset, and periodically during operation. If any of the configuration settings are changed, ensure that the conflict monitor triggers and causes the program card indicator to flash. Ensure that configuration change faults are only reset by depressing and holding the front panel reset button for three seconds. Ensure the external remote reset input does not reset configuration change faults.

Ensure the conflict monitor will trigger and the AC Power indicator will flash at a rate of 2 Hz \pm 20% with a 50% duty cycle when the AC Line voltage falls below the “drop-out” level. Ensure the conflict monitor will resume normal operation when the AC Line voltage returns above the “restore” level. Ensure the AC Power indicator will remain illuminated when the AC voltage returns above the “restore” level. Should an AC Line power interruption occur while the monitor is in the fault mode, then upon restoration of AC Line power, the monitor will remain in the fault mode and the correct fault and channel indicators will be displayed.

Provide a flash interval of at least 6 seconds and at most 10 seconds in duration following a power-up, an AC Line interruption, or a brownout restore. Ensure the conflict monitor will suspend all fault monitoring functions, close the Output relay contacts, and flash the AC indicator at a rate of 4 Hz \pm 20% with a 50% duty cycle during this interval. Ensure the termination of the flash interval after at least 6 seconds if the Watchdog input has made 5 transitions between the True and False state and the AC Line voltage is greater than the “restore” level. If the watchdog input has not made 5 transitions between the True and False state within 10 \pm 0.5 seconds, the monitor shall enter a WDT error fault condition.

Ensure the conflict monitor will monitor an intersection with a minimum of four approaches using the four-section Flashing Yellow Arrow (FYA) vehicle traffic signal as outlined by the NCHRP 3-54 research project for protected-permissive left turn signal displays. Ensure the conflict monitor will operate in the FYA mode and FYAc (Compact) mode as specified below to monitor each channel pair for the following fault conditions: Conflict, Flash Rate Detection, Red Fail, Dual Indication, and Clearance. Provide a switch to select between the FYA mode and FYAc mode. Provide a switch to select each FYA phase movement for monitoring.

| FYA Mode | | | | |
|-----------------------|------------------|-------------------|-------------------|-------------------|
| FYA Signal Head | Phase 1 | Phase 3 | Phase 5 | Phase 7 |
| Red Arrow | Channel 9 Red | Channel 10 Red | Channel 11 Red | Channel 12 Red |
| Yellow Arrow | Channel 9 Yellow | Channel 10 Yellow | Channel 11 Yellow | Channel 12 Yellow |
| Flashing Yellow Arrow | Channel 9 Green | Channel 10 Green | Channel 11 Green | Channel 12 Green |
| Green Arrow | Channel 1 Green | Channel 3 Green | Channel 5 Green | Channel 7 Green |

◆ **Revision No. 1, April 10, 2017 - This document supersedes version originally issued and sealed by J. Todd Brooks, NCPE No. 017586 on 12/28/2016**

| FYAc Mode | | | | |
|-----------------------|------------------|------------------|------------------|-------------------|
| FYA Signal Head | Phase 1 | Phase 3 | Phase 5 | Phase 7 |
| Red Arrow | Channel 1 Red | Channel 3 Red | Channel 5 Red | Channel 7 Red |
| Yellow Arrow | Channel 1 Yellow | Channel 3 Yellow | Channel 5 Yellow | Channel 7 Yellow |
| Flashing Yellow Arrow | Channel 1 Green | Channel 3 Green | Channel 5 Green | Channel 7 Green |
| Green Arrow | Channel 9 Green | Channel 9 Yellow | Channel 10 Green | Channel 10 Yellow |

If a FYA channel pair is enabled for FYA operation, the conflict monitor will monitor the FYA logical channel pair for the additional following conditions:

1. **Conflict:** Channel conflicts are detected based on the permissive programming jumpers on the program card. This operation remains unchanged from normal operation except for the solid Yellow arrow (FYA clearance) signal.

Yellow Change Interval Conflict: During the Yellow change interval of the Permissive Turn channel (flashing Yellow arrow) the conflict monitor shall verify that no conflicting channels to the solid Yellow arrow channel (clearance) are active. These conflicting channels shall be determined by the program card compatibility programming of the Permissive Turn channel (flashing Yellow arrow). During the Yellow change interval of the Protected Turn channel (solid Green arrow) the conflict monitor shall verify that no conflicting channels to the solid Yellow arrow channel (clearance) are active as determined by the program card compatibility programming of the Protected Turn channel (solid Green arrow).

2. **Flash Rate Detection:** The conflict monitor unit shall monitor for the absence of a valid flash rate for the Permissive turn channel (flashing Yellow arrow). If the Permissive turn channel (flashing Yellow arrow) is active for a period greater than 1600 milliseconds, ensure the conflict monitor triggers and puts the intersection into flash. If the Permissive turn channel (flashing Yellow arrow) is active for a period less than 1400 milliseconds, ensure the conflict monitor does not trigger. Ensure the conflict monitor will remain in the triggered (in fault mode) state until the unit is reset at the front panel or through the external remote reset input. Provide a jumper or switch that will enable and disable the Flash Rate Detection function. Ensure that when the jumper is not present or the switch is in the OFF position the Flash Rate Detection function is enabled. Ensure that when the jumper is present or the switch is in the ON position the Flash Rate Detection function is disabled.
3. **Red Monitoring or Absence of Any Indication (Red Failure):** The conflict monitor unit shall detect a red failure if there is an absence of voltage on all four of the inputs of a FYA channel pair (RA, YA, FYA, GA).
4. **Dual Indications on the Same Channel:** The conflict monitor unit shall detect a dual indication if two or more inputs of a FYA channel pair (RA, YA, FYA, GA) are "on" at the same time.

Short/Missing Yellow Indication Fault (Clearance Error): The conflict monitor unit shall monitor the solid Yellow arrow for a clearance fault when terminating both the Protected Turn

◆ **Revision No. 1, April 10, 2017 - This document supersedes version originally issued and sealed by J. Todd Brooks, NCPE No. 017586 on 12/28/2016**

U-4715B**ITS-183****Buncombe County**

channel (solid Green arrow) interval and the Permissive Turn channel (flashing Yellow arrow) interval.

Ensure that the conflict monitor will log at least nine of the most recent events detected by the monitor in non-volatile EEPROM memory (or equivalent). For each event, record at a minimum the time, date, type of event, status of each field signal indication with RMS voltage, and specific channels involved with the event. Ensure the conflict monitor will log the following events: monitor reset, configuration, previous fault, and AC line. Furnish the signal sequence log that shows all channel states (Greens, Yellows, and Reds) and the Red Enable State for a minimum of 2 seconds prior to the current fault trigger point. Ensure the display resolution of the inputs for the signal sequence log is not greater than 50 ms.

Provide a conflict monitor with an Ethernet 10/100 Mbps, RJ-45 port for data communication access to the monitor by a local notebook computer and remotely via a workstation or notebook computer device connected to the signal system local area network. The Ethernet port shall be electrically isolated from the conflict monitor's electronics and shall provide a minimum of 1500 Vrms isolation. Integrate monitor with Ethernet network in cabinet. Provide software to retrieve the time and date from a network server in order to synchronize the on-board times between the conflict monitor and the controller. Furnish and install the following Windows based, graphic user interface software on workstations and notebook computers where the signal system client software is installed: 1) software to view and retrieve all event log information; 2) software that will search and display a list of conflict monitor IP addresses and IDs on the network; and 3) software to change the conflict monitor's network parameters such as IP address and subnet mask.

◆ **Revision No. 1, April 10, 2017 - *This document supersedes version originally issued and sealed by J. Todd Brooks, NCPE No. 017586 on 12/28/2016***

U-4715B

ITS-184

Buncombe County

MONITOR BOARD EDGE CONNECTOR

| Pin # | Function (Back Side) | Pin # | Function (Component Side) |
|--------------|-----------------------------|--------------|----------------------------------|
| 1 | Channel 2 Green | A | Channel 2 Yellow |
| 2 | Channel 13 Green | B | Channel 6 Green |
| 3 | Channel 6 Yellow | C | Channel 15 Green |
| 4 | Channel 4 Green | D | Channel 4 Yellow |
| 5 | Channel 14 Green | E | Channel 8 Green |
| 6 | Channel 8 Yellow | F | Channel 16 Green |
| 7 | Channel 5 Green | H | Channel 5 Yellow |
| 8 | Channel 13 Yellow | J | Channel 1 Green |
| 9 | Channel 1 Yellow | K | Channel 15 Yellow |
| 10 | Channel 7 Green | L | Channel 7 Yellow |
| 11 | Channel 14 Yellow | M | Channel 3 Green |
| 12 | Channel 3 Yellow | N | Channel 16 Yellow |
| 13 | Channel 9 Green | P | Channel 17 Yellow |
| 14 | Channel 17 Green | R | Channel 10 Green |
| 15 | Channel 11 Yellow | S | Channel 11 Green |
| 16 | Channel 9 Yellow | T | Channel 18 Yellow |
| 17 | Channel 18 Green | U | Channel 10 Yellow |
| -- | | -- | |
| 18 | Channel 12 Yellow | V | Channel 12 Green |
| 19 | Channel 17 Red | W | Channel 18 Red |
| 20 | Chassis Ground | X | Not Assigned |
| 21 | AC- | Y | DC Common |
| 22 | Watchdog Timer | Z | External Test Reset |
| 23 | +24VDC | AA | +24VDC |
| 24 | Tied to Pin 25 | BB | Stop Time (Output) |
| 25 | Tied to Pin 24 | CC | Not Assigned |
| 26 | Not Assigned | DD | Not Assigned |
| 27 | Relay Output, Side #3, N.O. | EE | Relay Output, Side #2, Common |
| 28 | Relay Output, Side #1, N.C. | FF | AC+ |

-- Slotted for keying between Pins 17/U and 18/V

◆ **Revision No. 1, April 10, 2017 - This document supersedes version originally issued and sealed by J. Todd Brooks, NCPE No. 017586 on 12/28/2016**

U-4715B

ITS-185

Buncombe County

CONFLICT PROGRAM CARD PIN ASSIGNMENTS

| Pin # | Function (Back Side) | Pin # | Function (Component Side) |
|--------------|-----------------------------|--------------|----------------------------------|
| 1 | Channel 2 Green | A | Channel 1 Green |
| 2 | Channel 3 Green | B | Channel 2 Green |
| 3 | Channel 4 Green | C | Channel 3 Green |
| 4 | Channel 5 Green | D | Channel 4 Green |
| 5 | Channel 6 Green | E | Channel 5 Green |
| 6 | Channel 7 Green | F | Channel 6 Green |
| 7 | Channel 8 Green | H | Channel 7 Green |
| 8 | Channel 9 Green | J | Channel 8 Green |
| 9 | Channel 10 Green | K | Channel 9 Green |
| 10 | Channel 11 Green | L | Channel 10 Green |
| 11 | Channel 12 Green | M | Channel 11 Green |
| 12 | Channel 13 Green | N | Channel 12 Green |
| 13 | Channel 14 Green | P | Channel 13 Green |
| 14 | Channel 15 Green | R | Channel 14 Green |
| 15 | Channel 16 Green | S | Channel 15 Green |
| 16 | N/C | T | PC AJAR |
| 17 | Channel 1 Yellow | U | Channel 9 Yellow |
| 18 | Channel 2 Yellow | V | Channel 10 Yellow |
| 19 | Channel 3 Yellow | W | Channel 11 Yellow |
| 20 | Channel 4 Yellow | X | Channel 12 Yellow |
| 21 | Channel 5 Yellow | Y | Channel 13 Yellow |
| 22 | Channel 6 Yellow | Z | Channel 14 Yellow |
| 23 | Channel 7 Yellow | AA | Channel 15 Yellow |
| 24 | Channel 8 Yellow | BB | Channel 16 Yellow |
| -- | | -- | |
| 25 | Channel 17 Green | CC | Channel 17 Yellow |
| 26 | Channel 18 Green | DD | Channel 18 Yellow |
| 27 | Channel 16 Green | EE | PC AJAR (Program Card) |
| 28 | Yellow Inhibit Common | FF | Channel 17 Green |

-- Slotted for keying between Pins 24/BB and 25/CC

◆ **Revision No. 1, April 10, 2017 - This document supersedes version originally issued and sealed by J. Todd Brooks, NCPE No. 017586 on 12/28/2016**

U-4715B**ITS-187****Buncombe County**

Provide relay SSR1 as a Triac SPST normally open solid state relay that is rated for 120 VAC input and zero-crossing (resistive load) 25 amp @ 120 VAC output. Ensure the relay turns on at 90 Vrms within 10 ms and turns off at 10 Vrms within 40 ms. Ensure the relay has physical characteristics as shown in the wiring detail in Figure 1. Provide 4 terminal screws with saddle clamps.

Provide fuses F1 and F2 as a UL Listed ¼" x 1-1/4" glass tube rated at 250 volts with a 10kA interrupting rating. Ensure F1 non-delay (fast-acting) and F2 slow-blow (time-delay) fuses have a maximum opening times of 60 minutes and 120 seconds for currents of 135 and 200 percent of the ampere rating, respectively. Ensure F2 slow-blow (time-delay) fuses have a minimum opening times of 12 seconds at 200 percent of the ampere rating. Provide fuse holders that are UL Recognized panel-mounted holders rated 250V, 15 ampere minimum with bayonet-type knobs which accept ¼" x 1-1/4" glass tube fuses.

Provide terminal blocks that are rated for 300V and are made of electrical grade thermoplastic or thermosetting plastic. Ensure each terminal block is of closed back design and has recessed-screw terminals with molded barriers between terminals. Ensure each terminal block is labeled with a block designation. Ensure each terminal is labeled with the function and a number.

Provide 3/4-inch diameter radial lead UL-recognized metal oxide varistors (MOVs) that have electrical performance as outlined below.

| PROPERTIES OF MOV SURGE PROTECTOR | |
|--|--------------------------|
| Maximum Continuous Applied Voltage at 185° F | 150 VAC (RMS) 200 VDC |
| Maximum Peak 8x20µs Current at 185° F | 6500 A |
| Maximum Energy Rating at 185° F | 80 J |
| Voltage Range 1 mA DC Test at 77° F | 212-268 V |
| Max. Clamping Voltage 8x20µs, 100A at 77° F | 395 V |
| Typical Capacitance (1 MHz) at 77° F | 1600 pF |

Provide resistor R1 as a 2K ohm, 12 watt, wirewound resistor with tinned terminals and attaching leads. Ensure the resistor is spaced apart from surrounding wires.

Provide a LED or incandescent lamp that has a voltage rating of 120 VAC with a minimum life rating at 50,000 hours.

Wire the preemption and sign control box as shown in Figure 1.

◆ **Revision No. 1, April 10, 2017 - This document supersedes version originally issued and sealed by J. Todd Brooks, NCPE No. 017586 on 12/28/2016**

U-4715B

ITS-189

Buncombe County

27.8. MATERIALS – TYPE 170 DETECTOR SENSOR UNITS

Furnish detector sensor units (i.e., detector cards) that comply with Chapter 5, Section 1, “General Requirements” and Chapter 5, Section 2, “Model 222 & 224 Loop Detector Sensor Units,” of the CALTRANS *Transportation Electrical Equipment Specifications*, dated March 12, 2009 with Erratum 1.

27.9. CONSTRUCTION METHODS**A. General**

Identify and label all field wiring (e.g., signal conductors, pushbutton wires, loop detector lead-ins, etc.) in existing controller cabinets prior to disconnecting any field wiring.

Remove existing controllers and cabinets where required. Remove the maintenance diary from the existing cabinet and place it in the new cabinet. Take existing equipment out of service only at the time directed. Provide a law enforcement officer(s) to direct traffic through the signalized intersection while the signal is inoperable. Complete installation the new controller and cabinet and **restore signal operations within 3 hours** of taking the existing controller and cabinet out of service.

Turn to the next clean page (i.e., next page with no entries) in the diary and make an entry on the new page upon installation of the new controller and cabinet to document the date and time of installation. Maintain the maintenance diary and update it upon each subsequent visit to the cabinet until final acceptance of the project.

If the existing maintenance diary is found to be in poor condition or nearly full, notify the Engineer to have the City provide a new diary. Upon receipt of the new maintenance diary, place the new diary inside the cabinet and give the old diary to the Engineer for return to the City for archiving. Prior to removing the existing maintenance diary, make an entry in the old diary to document the date and time it was removed from the cabinet and turned over to the Engineer. Make the initial entry in the new maintenance diary to document the date and time of installation of the new cabinet and controller and the date the new maintenance diary was placed inside the cabinet. Maintain the maintenance diary and update it upon each subsequent visit to the cabinet until final acceptance of the project.

Locate new cabinets so as not to obstruct sight distance of vehicles turning on red.

Install controllers, cabinets, detector sensor units, and hardware that provide required phasing, color sequence, flash sequence, interconnection, railroad clearance and preemption, and emergency vehicle clearance and preemption.

Where the Plans call for using existing upstream detection loops for both local intersection and system detection (i.e., shared local/system loops), install new lead-ins and additional new detector units as required to break out the loops onto separate lead-ins and channels. Refer to the “Lead-in Cable” section of these Project Special Provisions for additional requirements concerning the proposed shared system/local detection loops.

For all Department-owned signals, stencil the signal inventory number on both the front and rear doors of the cabinet. For all City-owned signals, apply a City-furnished decal with the City signal inventory number (i.e., intersection number) on both the front and rear doors of the cabinet.

◆ **Revision No. 1, April 10, 2017 - This document supersedes version originally issued and sealed by J. Todd Brooks, NCPE No. 017586 on 12/28/2016**

U-4715B**ITS-190****Buncombe County**

Provide external electrical service disconnect, mounted independent of the cabinet, at all new cabinet locations and at existing cabinet locations where specified in the Plans.

Do not program controller for late night flashing operation at railroad preemption installations. For all other installations, do not program controller for late night flashing operation unless otherwise directed. Ensure all signal heads for same approach flash concurrently during flashing operation.

Provide serial number and cabinet model number for each new controller and controller cabinet installed.

When installing a pole mounted cabinet in a new location or in an existing location where new risers and cabling are replacing existing risers and cabling, mount the cabinet so that the height to cabinet middle is 4 feet from the ground below. Avoid mounting cabinets so that they overhang and encroach upon an adjacent sidewalk or pedestrian path. Where a minor overhang of the sidewalk or pedestrian path cannot reasonably be avoided, ensure that a minimum of 4 feet of clear sidewalk width will remain once the cabinet is installed. Do not mount cabinets where one of its doors opens into a street, driveway or other area subject to vehicular traffic or where an existing physical feature such as a pole, sign post, down guy, shrub or tree prevents its doors from being opened at least 90 degrees.

When replacing an existing pole-mounted cabinet with a new pole-mounted cabinet and the existing risers and cabling are being retained, mount the new cabinet so that the cabinet bottom rests upon the existing riser connections even though this causes the cabinet middle to be higher or lower than 4 feet above ground, unless the Plans indicate or the Engineer directs otherwise. Comply with the cabinet layout shown in *Roadway Standard Drawing* No. 1751.01, Sheet 2 of 2.

Do not construct new conduit entry holes into existing metal poles to attain the 4-foot mounting height.

Program and activate controllers with proposed phasing and timing.

Install all updates to the local controller software and OS9 operating system software during the life of the project up through final acceptance of the project, including existing 2070L controllers that will be retained and incorporated into the upgraded and expanded Asheville Signal System.

Once all new cables have been installed in and existing cables, where applicable, have been removed from base-mounted cabinets, seal all conduits entering the cabinet base as follows:

- Seal spare conduits with approved conduit plugs.
- Seal conduits containing fiber-optic communications cable with duct and conduit sealer.
- Seal conduits containing signal cable, and loop lead-in wire with duct and conduit sealer.

Seal existing conduits as well as new conduits, regardless of whether cables are being removed from or installed in them. Comply with the requirements for conduit plugs and duct and conduit sealer in the “Underground Conduit” section of these Project Special Provisions.

Some intersections with existing base-mounted cabinets within and near downtown Asheville currently have foundations that protrude several inches above ground and that are smaller than

◆ **Revision No. 1, April 10, 2017 - This document supersedes version originally issued and sealed by J. Todd Brooks, NCPE No. 017586 on 12/28/2016**

U-4715B**ITS-191****Buncombe County**

the base of the new 336S and 332 cabinets being installed. Enlarging or replacing many of these bases is infeasible due to right-of-way and other physical constraints and, as a result, they must be retained for base-mounting the new controller cabinets. Position the new controller cabinet with its base extender attached over the existing conduit spread and in such a way as to minimize the overhang of each side of the base extender, especially on sides adjacent to sidewalk. Obtain the Engineer's approval of the cabinet's position on the foundation before anchoring the base extender to the existing foundation. Furnish and install an aluminum plate(s) of the same thickness as the base extender flange to fill any gap between the opening in the base extender and the edge of the existing foundation as needed.

B. Electrical Service and Grounding

Where electrical services do not include an external electrical service disconnect, modify or replace the electrical service as shown in the Plans to add an electrical service disconnect and a new grounding electrode system.

Furnish and install a grounding electrode system at all new electrical services.

Comply with all requirements of the "Electrical Service" section of these Project Special Provisions.

C. Edge Switch

Install and program the Ethernet edge switches in accordance with the "Communications Hardware" section of these Project Special Provisions.

D. Workshop

Provide enclosed workshop to store, set up and test new controllers and cabinets before installation. Locate workshop within the City Limits of Asheville. Ensure workshop provides protection from weather and sufficient space to house two test observers, all necessary test equipment and material, controllers and cabinets. Provide the workshop until final acceptance of the project.

Configure and test each controller and cabinet to match the proposed signal design. Ensure all equipment furnished and installed or modified by the Contractor at each location operates in full compliance with the Plans and Project Special Provisions. Test each controller and cabinet for proper color sequence, flashing operation, phase timings, preemption, coordination, and conflict monitor programming. Ensure that simultaneous conflicting phase outputs will cause the cabinet to revert to flashing operation. For intersections with any type of preemption, submit a completed Preemption Test Procedure Checklist. The checklist is located on the Department's Website.

Test the cabinet and controller for eight hours minimum. Following this test, and before installation, the Engineer will inspect the equipment in operation. The Engineer may require other tests to ensure proper operation. These tests shall be at no additional cost to the Department.

E. GPS Coordinates

Provide real world coordinates for all junction boxes and equipment cabinets installed or utilized under this project. Provide the coordinates in feet units using the North Carolina State Plane coordinate system (1983 North American Datum also known as NAD '83). Furnish

◆ **Revision No. 1, April 10, 2017 - This document supersedes version originally issued and sealed by J. Todd Brooks, NCPE No. 017586 on 12/28/2016**

U-4715B

ITS-192

Buncombe County

coordinates that do not deviate more than 1.7 feet in the horizontal plane and 3.3 feet in the vertical plane. Global positioning system (GPS) equipment able to obtain the coordinate data within these tolerances may be used. Submit cut sheets on the GPS unit proposed to collect the data for approval by the Engineer.

Provide both digital copies and hard copies of all information regarding the location (including to but not limited to manufacturer, model number, City system ID number and NCDOT inventory number) in the Microsoft Excel[®] spreadsheet using the format shown in example below. In addition to Excel format, provide a digital copy of the location information as an ESRI Shapefile (.SHP file format).

| City System ID# | NCDOT Inv # | Name | Location | Latitude | Longitude | Manufacturer | Model # |
|-----------------|-------------|------------------------------------|---|----------|-----------|--------------|-------------------------------------|
| | 05-0134 | Equipment Cabinet | US 70 at Raynor Rd./ Auburn-Knightdale | -78.5500 | 35.6873 | McCain | Type-332 |
| | | Junction Box # 1 (Phase 2 Side) | US 70 at Raynor Rd./ Auburn-Knightdale | -78.5516 | 35.6879 | Quazite | PG1118BA12(Box) PG118HA00(Cover) |
| | | Junction Box # 2 (Phase 2 Side) | US 70 at Raynor Rd./ Auburn-Knightdale | -78.5506 | 35.6876 | Quazite | PG1118BA12(Box) PG118HA00(Cover) |
| | | Junction Box # 3 (Near Cabinet) | US 70 at Raynor Rd./ Auburn-Knightdale | -78.5501 | 35.6873 | Quazite | PG1118BA12(Box) PG118HA00(Cover) |
| | | Junction Box # 4 (Phase 6 Side) | US 70 at Raynor Rd./ Auburn-Knightdale | -78.5486 | 35.6873 | Quazite | PG1118BA12(Box) PG118HA00(Cover) |
| | | Junction Box # 5 (Phase 6 Side) | US 70 at Raynor Rd./ Auburn-Knightdale | -78.5493 | 35.6876 | Quazite | PG1118BA12(Box) PG118HA00(Cover) |
| | | Junction Box # 6 (Phase 4 Side) | US 70 at Raynor Rd./ Auburn-Knightdale | -78.5503 | 35.6879 | Quazite | PG1118BA12(Box) PG118HA00(Cover) |

27.10. MEASUREMENT AND PAYMENT

Controller with cabinet (____) will be measured and paid as the actual number of each type of controllers with cabinets of each type and mounting method that are furnished, installed, and accepted, subject to the following conditions: 90% of the payment will be made upon acceptance of the unit; 10% of the payment will be made following final acceptance of the integrated system (including completion of the 60-day observation period).

Controller with cabinet and aux file (____) will be measured and paid as the actual number of each type of controllers with cabinets equipped with auxiliary output files of each type and mounting method that are furnished, installed, and accepted, subject to the following conditions: 90% of the payment will be made upon acceptance of the unit; 10% of the payment will be made following final acceptance of the integrated system (including completion of the 60-day observation period).

No measurement will be made of conflict monitors, grounding systems, modems and workshop as these will be considered incidental to furnishing and installing controllers with cabinets and controllers with cabinets and aux files.

No measurement will be made of aluminum plates furnished and installed to fill gaps between the opening of a cabinet base extender and the edge of smaller existing cabinet foundations when required as such work will be considered incidental to furnishing and installing controllers with cabinets.

◆ **Revision No. 1, April 10, 2017 - This document supersedes version originally issued and sealed by J. Todd Brooks, NCPE No. 017586 on 12/28/2016**

U-4715B**ITS-193****Buncombe County**

New and modified electrical services and electrical service grounding systems will be measured and paid for in accordance with the “Electrical Service” section of these Project Special Provisions.

Detector card (Model 222) will be measured and paid as the actual number of Model 222 detector cards furnished, installed, and accepted.

Ethernet edge switches will be measured and paid for in accordance with the “Communications Hardware” section of these Project Special Provisions.

Lead-in cable will be measured and paid for in accordance with the “Lead-in Cable” section of these Project Special Provisions.

No measurement or payment will be made of any hardware and fasteners required for mounting controller cabinets to poles and foundations as these items will be considered incidental to installing controllers with cabinets.

No measurement or payment will be made of conduit nipples, fittings, signal cable, service wire, locknuts and bushings or other materials necessary to mount a new pole-mounted cabinet in the same location as an existing pole-mounted cabinet that is being replaced.

No measurement or payment will be made of sealing conduits with duct plugs, mechanical sealing devices and duct and conduit sealer as such work will be considered incidental to furnishing and installing controllers with cabinets.

No measurement will be made of collecting and recording GPS coordinates for controller cabinets and junction boxes, compiling this data in the prescribed Microsoft Excel[®] spreadsheet and providing an ESRI Shapefile (.SHP file format) as such work will be considered incidental installing controllers with cabinets and installing controllers.

The special anti-graffiti, gray power-coated finish for controller cabinet where called for in the Plans will be measured and paid for in accordance with the “Special Coating for Cabinets” section of these Project Special Provisions.

Payment will be made under:

| Pay Item | Pay Unit |
|---|-----------------|
| Controller with Cabinet (2070E, 336S, Pole Mounted) | Each |
| Controller with Cabinet (2070E, 336S, Base Mounted) | Each |
| Controller with Cabinet (2070E, 332, Base Mounted) | Each |
| Controller with Cabinet and Aux File (2070E, 332, Base Mounted) | Each |
| Detector Card (Model 222) | Each |

◆ **Revision No. 1, April 10, 2017 - This document supersedes version originally issued and sealed by J. Todd Brooks, NCPE No. 017586 on 12/28/2016**

28. CABINET BASE ADAPTER AND BASE EXTENDER

28.1. DESCRIPTION

Furnish and install cabinet base adapters and base extenders with all necessary hardware for 170E-family cabinets.

28.2. MATERIALS

Fabricate base adapters and extenders from the same materials and with the same finish as cabinet housing. Fabricate base adapter and extender in the same manner as controller cabinets, meeting all applicable specifications called for in Section 7.5 of CALTRANS TEES (11/19/99). Provide base adapters and extenders that have a minimum height of 12". Provide cabinet base adapters that comply with the details shown in the Plans.

Some intersections with existing base-mounted cabinets within and near downtown Asheville currently have foundations that protrude several inches above ground and that are smaller than the base of the new 336S and 332 cabinets being installed. Enlarging or replacing many of these bases is infeasible due to right-of-way and other physical constraints and, as a result, they must be retained for base-mounting the new controller cabinets. Furnish an aluminum plate(s) of the same thickness as the base extender flange to fill any gap between the opening in the base extender and the edge of such existing foundation as needed.

For certain locations within local historic districts in Asheville as designated in the Plans, provide base extenders and base adapters with a special medium gray powder-coated finish and anti-graffiti coating in accordance with the "Special Coating for Cabinets" section of these Project Special Provisions. The locations include:

- Montford Avenue at Cullowhee Street (COA-411)
- Victoria Road at Fernihurst Drive (COA-016)
- McDowell Street at Lodge Street (13-0389)
- Hendersonville Road at Vanderbilt Road/All Souls Crescent (13-0241)
- Hendersonville Road at Lodge Street (13-0242)

28.3. CONSTRUCTION METHODS

A. General

Unless otherwise shown in the Plans, install a cabinet base extender at locations requiring a new Model 332 cabinet on an existing/modified or new foundation and where an existing base-mounted Model 332 cabinet that is being retained does not have a cabinet base extender.

Install a cabinet base adapter at locations requiring a new Model 332 cabinet to be installed on an existing/modified foundation where the opening in the bottom of a cabinet base extender will not fit over the existing conduit spread. Unless otherwise directed by the Engineer, install cabinet base adapters only at locations indicated in the Plans. Do not install cabinet base adapters where the plans call for use of a cabinet base extender without the prior approval of the Engineer.

◆ **Revision No. 1, April 10, 2017 - This document supersedes version originally issued and sealed by J. Todd Brooks, NCPE No. 017586 on 12/28/2016**

U-4715B**ITS-195****Buncombe County**

Where the plans require a Model 336 cabinet to be base mounted, install a cabinet base adapter or extender, as required.

Use permanent, flexible waterproof sealing material to:

- Seal between cabinet base and cabinet base adapter/extender, and
- Seal space between cabinet base adapter/extender and foundation.

B. Installation on Pedestal Bases Downtown

Position the new controller cabinet with its base extender attached over the existing conduit spread and in such a way as to minimize the overhang of each side of the base extender, especially on sides adjacent to sidewalk. Obtain the Engineer's approval of the cabinet's position on the foundation before anchoring the base extender to the existing foundation. Install an aluminum plate(s) of the same thickness as the base extender flange to fill any gap between the opening in the base extender and the edge of the existing foundation as needed.

28.4. MEASUREMENT AND PAYMENT

Cabinet base extender will be measured and paid as the actual number of cabinet base extenders furnished, installed, and accepted.

Cabinet base adapter will be measured and paid as actual number of cabinet base adapters furnished, installed, and accepted.

The special anti-graffiti, gray power-coated finish for cabinet base extenders and bases adapters where called for in the Plans will be measured and paid for in accordance with the "Special Coating for Cabinets" section of these Project Special Provisions.

No measurement will be made of aluminum plates furnished and installed to fill gaps between the opening of a cabinet base extender and the edge of smaller existing cabinet foundations when required as such work will be considered incidental to furnishing and installing cabinet base extenders and cabinet base adapters.

Payment will be made under:

| Pay Item | Pay Unit |
|-----------------------|-----------------|
| Cabinet Base Extender | Each |
| Cabinet Base Adapter | Each |

U-4715B

ITS-196

Buncombe County

29. SPECIAL COATING FOR CABINETS

29.1. DESCRIPTION

Furnish and apply a special medium gray powder-coated finish with anti-graffiti coating to controller cabinets, CCTV cabinets and cabinet base extenders and adapters for designated locations in Asheville local historic districts as shown in the Plans.

29.2. MATERIALS

Provide a thermosetting powder-coated finish that is medium gray in color with an additional anti-graffiti top coating. The medium gray color shall be FED-STD-595C color number 26314 or 36314, or similar color approved by Engineer and the City of Asheville. Provide a coating that is UV-fade resistant and scratch resistant. Ensure that the coating results in a low luster, satin finish. Coatings with a glossy finish are prohibited. Contact Alex Cole, the City of Asheville's Historic Resources Specialist by phone at 828-259-5638 and by email at acole@ashevillenc.gov to confirm the color to be used to coat these cabinets and base extenders/adapters within local historic districts in Asheville.

Prior to applying the special coating to the equipment, submit to the Engineer for City approval sample chips, 2 x 4 inches on sheet aluminum, of the medium gray powder coating along with catalog cuts/product data sheets from the manufacturer for the coatings proposed. Submit sample chips of the powder coating both with and without the anti-graffiti coating. Do not apply the coating to any equipment without the prior approval of the Engineer and the City of Asheville's Historic Resources Specialist.

29.3. CONSTRUCTION METHODS

Apply the special coating to new equipment only and in accordance with the instructions of the coating manufacturer. Properly prepare the aluminum surfaces that will receive the special coating in accordance with coating manufacturer's specifications. Factory-apply the coating indoors in a temperature and humidity-controlled environment. Electrostatically apply the dry powder finish and oven-cure the finish following application of the powder. Verify through appropriate testing that the finished coating achieves a minimum dry film thickness of 2.4 mils.

Field application of the coating is prohibited. Apply the coating only to the exterior of the cabinet, base extender or base adapter; do not apply the coating to interior of the equipment.

29.4. MEASUREMENT AND PAYMENT

Special coating (332 cabinet) will be measured and paid as the actual number of Model 332 cabinets to which a special coating is applied and accepted.

Special coating (336 cabinet) will be measured and paid as the actual number of Model 336 cabinets to which a special coating is applied and accepted. Measurement and payment will be without regard to cabinet mounting (i.e., pole or base) and Model 336 cabinet subtype (i.e., 336A vs. 336S).

Special coating (base adapter/extender) will be measured and paid as the actual number of cabinet base adapters and cabinet base extenders to which a special coating is applied and accepted.

◆ **Revision No. 1, April 10, 2017 - This document supersedes version originally issued and sealed by J. Todd Brooks, NCPE No. 017586 on 12/28/2016**

U-4715B

ITS-197

Buncombe County

Payment will be made under:

| Pay Item | Pay Unit |
|---|-----------------|
| Special Coating (332 Cabinet) | Each |
| Special Coating (336 Cabinet) | Each |
| Special Coating (Base Extender/Adapter) | Each |

◆ Revision No. 1, April 10, 2017 - *This document supersedes version originally issued and sealed by J. Todd Brooks, NCPE No. 017586 on 12/28/2016*

30. ELECTRICAL SERVICE

30.1. DESCRIPTION

At locations called out in the Plans, install a new electrical service and modify an existing electrical service, including an external disconnect and meter base.

Comply with the National Electrical Code (NEC), the National Electrical Safety Code (NECS), the *Standard Specifications*, these Project Special Provisions, and all local ordinances. Coordinate all work involving electrical service with the appropriate utility company and the Engineer.

30.2. MATERIALS

A. Electrical Service

Provide material, equipment and hardware under this section that is pre-approved on the 2012 ITS and Signals QPL by the date of equipment installation.

Provide, modify and/or upgrade all materials necessary to form a complete electrical service assembly as shown in the Plans. Furnish new external electrical service disconnects, meter bases, and required grounding. Replace electrical service feeder conductors and conduits between the disconnects and the controller cabinets as required.

Provide external electrical service disconnects at all new and existing cabinet locations unless otherwise specified in the Plans. Where electrical services do not include an external electrical service disconnect, modify service to include electrical service disconnect and a new grounding electrode system.

Provide all electrical service disconnects with a space/expansion slots, covered by a knockout or removable blank cover, designed to allow the future installation of at least one additional circuit breaker.

Provide inverse time circuit breaker with at least 10,000 RMS symmetrical amperes short circuit current rating in a lockable NEMA 3R enclosure.

Furnish 3-wire stranded #8 AWG copper service conductors with THWN rating for supplying power to the meter base/disconnects where only one device is being connected (1 signal cabinet or 1 CCTV cabinet). Furnish 3-wire stranded #3 AWG copper service conductors with THWN rating for supplying power to the meter base/disconnect where multiple devices are sharing the service. Provide conductors with black, red, and white insulation that are intended for power circuits at 600 V or less and comply with the following:

- Listed as meeting UL Standard UL-83
- Meets ASTM B-3 and B-8 or B-787 standards.

Furnish 3-wire stranded copper feeder conductors with THWN rating for supplying power to field equipment cabinets. Provide conductors with black, white, and green insulation that are intended for power circuits at 600 V or less and comply with the following:

- Listed as meeting UL Standard UL-83
- Meets ASTM B-3 and B-8 or B-787 standards.

◆ **Revision No. 1, April 10, 2017 - This document supersedes version originally issued and sealed by J. Todd Brooks, NCPE No. 017586 on 12/28/2016**

U-4715B**ITS-199****Buncombe County**

As indicated below, provide the following:

Traffic Signal Cabinet:

- 1 single-pole 50A breaker
- 1 spare slot/space (minimum)
- 3-wire stranded #8 AWG copper feeder conductors with THWN rating

CCTV Camera Cabinet:

- 1 single-pole 15A breaker
- 1 spare slot/space (minimum)
- 3-wire stranded #12 AWG copper feeder conductors with THWN rating

Traffic Signal Cabinet and CCTV Camera Cabinet:

- 1 single-pole 50A breaker (Signal)
- 1 single-pole 15A breaker (CCTV)
- 1 spare slot/space (minimum)
- 3-wire stranded #8 AWG copper feeder conductors with THWN rating (Signal)
- 3-wire stranded #12 AWG copper feeder conductors with THWN rating (CCTV)

Furnish 1" rigid galvanized conduit between the disconnect and the equipment cabinets as required. For underground runs greater than 10 feet in length, the Contractor may transition from 1" rigid galvanized conduit to 1" PVC conduit for the remainder of the underground run beyond the initial 10 feet. Furnish Schedule 40 PVC female adapters to connect the PVC conduit to the threaded end of the rigid galvanized conduit. The interior surface of one end of the PVC female adapter shall be compatibly threaded to connect it to the threaded end of the rigid metallic riser without the aid of additional fittings, hardware or adhesives. The opposite end of the adapter shall be non-threaded to permit a slip fit, glued connection to the underground PVC conduit.

Ensure service disconnects are listed as meeting UL Standard UL-489 and marked as being suitable for use as service equipment. Fabricate enclosure from galvanized steel. Provide ground bus and neutral bus with a minimum of four terminals with minimum wire capacity range of number 8 through number 2/0 AWG.

Furnish NEMA Type 3R meter base rated 100A minimum for overhead service and 200A minimum for underground service and that meets the requirements of the local utility. Provide meter base with ampere rating of meter sockets based on sockets being wired with insulated wire rated at least 167°. With each meter base, provide a blank meter socket cover made from UV stabilized polycarbonate or metal and that is either clear or gray in color to prevent access to interior of meter base until meter is installed by the local power company.

Furnish 4 terminal, 600 volt, single phase, 3 wire meter base that complies with the following:

- Line, Load, and Neutral Terminals accept #8 to 2/0 AWG copper/aluminum wire;
- Ringed or Ringless Type, with or without bypass;
- Made of galvanized steel;
- Listed as meeting UL Standard UL-414; and
- Overhead or underground service entrance as specified.

◆ **Revision No. 1, April 10, 2017 - This document supersedes version originally issued and sealed by J. Todd Brooks, NCPE No. 017586 on 12/28/2016**

U-4715B**ITS-200****Buncombe County**

Provide electrical service disconnects, meter bases, combination panel enclosures and pedestals with electrostatically applied dry powder paint finish with minimum thickness of 2.4 mils and that is light gray in color. All exterior surfaces must be powder coated steel.

Furnish 1" watertight hub (i.e., meter socket hub) for threaded rigid galvanized conduit with meter base.

If meter base and electrical service disconnect are supplied in the same enclosure (i.e., combination panel), ensure assembly is marked as being suitable for use as service equipment. Ensure combination meter and disconnect mounted in a pedestal for underground service is listed as meeting UL Standard UL-231. Otherwise, ensure combination meter and disconnect is listed as meeting UL Standard UL-67.

For all locations within the Asheville CBD and within historic districts, provide a combination panel with pedestal extension as shown in the Plans for all new ground-mounted electrical service assemblies for underground electrical service. Do not provide wood posts, steel U-channel posts, square tube sign posts, metal framing channels or any method other than an underground service pedestal to mount meter bases and disconnects for new underground electrical service within the CBD and historic districts. Provide combination panels with pedestals of sufficient length to attain a minimum embedment depth of 24 inches below grade when installed per the manufacturer's instructions.

For all other locations, provide a combination panel and a 6" x 6" pressure treated wood post for mounting the new electrical service assembly for underground service. Furnish a 6" x 6" pressure treated wood post of sufficient length to mount the electrical service assembly at the height required by the special details when the post is embedded into the ground at the required depth. Provide wood posts treated in accordance with the requirements for sign posts in Article 1082-4 of the *Standard Specifications*.

Provide a grounding electrode system at all new electrical services. Provide underground marker tape above ground grounding electrodes and buried ground wire. Provide all grounding electrodes and ground wire necessary to ensure that grounding system, whether existing or new, complies with all grounding requirements of these Project Special Provisions.

Where the Plans call for modifying an existing electrical service for a traffic signal, provide a single-pole 50A inverse time circuit breaker with at least 10,000 RMS symmetrical amperes short circuit current rating to replace an existing circuit breaker in an existing disconnect.

B. CCTV Cabinet Disconnect

Furnish new CCTV cabinet disconnect with a 15A circuit breaker at the locations shown in the Plans. Provide CCTV cabinet disconnects that have spaces (slots) for at least two breakers (one occupied by the 15A breaker + one future breaker) and a minimum of 10,000 RMS symmetrical amperes short circuit current rating in a lockable NEMA 3R enclosure. Ensure equipment cabinet disconnects are listed as meeting UL Standard UL-489 and marked as being suitable for use as service disconnects. Fabricate enclosure from galvanized steel and electrostatically apply dry powder paint finish, light gray in color, to yield a minimum thickness of 2.4 mils. All exterior surfaces must be powder coated steel. Provide ground bus and neutral bus with a minimum of four terminals and a minimum wire capacity range of number 8 through number 2 AWG.

◆ **Revision No. 1, April 10, 2017 - This document supersedes version originally issued and sealed by J. Todd Brooks, NCPE No. 017586 on 12/28/2016**

U-4715B

ITS-201

Buncombe County

C. Grounding Electrodes (Ground Rods)

Furnish 5/8"x10' copper clad steel grounding electrodes (ground rods), #4 AWG solid bare copper conductors, and exothermic welding kits for grounding system installations. Comply with the NEC, the *Standard Specifications*, these Project Special Provisions and the Plans.

30.3. CONSTRUCTION METHODS

A. General

All work involving electrical service shall be coordinated with the appropriate electric utility company. Coordinate with the utility company to ascertain the feasibility of installing electrical service at each location before performing any work. Obtain all required local permits before beginning work.

Run feeder conductors separately from all other conductors in a 1-inch rigid galvanized conduit. Do not allow feeder conductors to share conduits with any other conductors or cables. Do not route unfused electrical feeder conductors inside of metal poles. Permanently label conductors at all access points using nylon tags labeled with permanent ink. Ensure each conductor has a unique identifier. Label conductors immediately upon installation. Use component name and labeling scheme approved by the Engineer.

Use rigid galvanized conduit for all underground conduit runs 10 feet or less in length. For underground runs greater than 10 feet in length, the Contractor may transition from 1" rigid galvanized conduit to 1" PVC conduit for the remainder of the run beyond the initial 10 feet using an approved PVC female adapter. Apply thread seal tape to the threads of the rigid galvanized conduit before screwing the PVC adapter onto the threaded male end of the conduit. Connect the threaded female end of the PVC adapter to the threaded end of the rigid galvanized conduit, then connect the not threaded end of the adapter to the PVC conduit using a slip fit, glued connection.

Direct bury pedestals that support combination panel at a minimum embedment depth of 24 inches below grade.

For locations with new electrical service, install a 6" x 6" treated wood post a minimum of 3 feet into the ground and mount the electrical service equipment on the wood post.

Upon completion of electrical service installation and backfilling of all excavations, restore the disturbed ground to its original condition as determined and approved by the Engineer. For paved areas, replace removed or damaged pavement with in kind materials, matching the elevation, color, texture/finish and general appearance of the surrounding pavement in accordance with the "Equipment Cabinet Foundation" section of these Project Special Provisions. Refer to Section 1 of these Project Special Provisions for additional requirements concerning sidewalks and curbs in historic districts. For unpaved areas, backfill excavations with removed material, tamp the backfilled material and rake smooth the top 1½ inches. Finish unpaved areas flush with surrounding natural ground and to match the original contour of the ground. Seed with same type of grass as surrounding area and mulch the newly seeded area. If unpaved area was not grassed, replace the original ground cover in kind as directed by the Engineer.

Complete repairs to and restoration of all ground (paved and unpaved) disturbed for construction within five consecutive calendar days following initial removal. If the

◆ **Revision No. 1, April 10, 2017 - This document supersedes version originally issued and sealed by J. Todd Brooks, NCPE No. 017586 on 12/28/2016**

U-4715B

ITS-202

Buncombe County

Contractor fails to repair and restore the ground in accordance with these Project Special Provisions within the time frame specified, the Department reserves the right to make the necessary repairs, and all expenses incurred by the Department in making the repairs and restoring the ground will be deducted from payment due the Contractor, plus **\$500 liquidated damages per occasion, per day, or any portion thereof**, until corrected.

Install meter socket covers on new meter bases to block access to the wiring inside until the meter is attached to the meter base by the power company. Use only approved meter socket covers that comply with these Project Special Provisions; do not use cardboard, paper, plywood, sheet plastic, tape, etc. to cover the meter socket opening. Do not leave a meter socket uncovered.

Provide all necessary stainless steel banding hardware and clamps for securely attaching service disconnects, meter bases, combination panels and service conduits and risers to metal poles.

B. New Electrical Service for Traffic Signal

At locations identified in the Plans, install new electrical service for a traffic signal controller cabinet. Comply with *Roadway Standard Drawing* Nos. 1700.01 and 1700.02 as well as the special details entitled "Signal Cabinet Detail, Pole-Mounted" and "Ground Mounted Electrical Service Detail" provided in the Plans.

Install a new electrical service comprised of an external service disconnect as well as a meter base with meter socket cover, even if the new service is replacing an existing non-metered electrical service. After installation of the meter base with meter socket cover, the local power company will remove the meter socket cover and transfer the existing meter or install a new meter and make any necessary connections to the power lines.

For locations that have existing PVC service risers, replace the existing electrical service with a new electrical service that has a rigid galvanized riser, as described above.

C. New Electrical Service for CCTV

At locations identified in the Plans, install new electrical service for a CCTV cabinet in accordance with the details shown in the Plans. Install a new electrical service comprised of an external service disconnect and a meter base with meter socket cover housed in a combination panel. Mount the combination panel on the CCTV pole. After installation of the meter base with meter socket cover, the local power company will remove the socket cover and transfer the existing meter or install a new meter and make any necessary connections to the power lines.

Unless the Plans indicate otherwise, have the power company route the service drop underground to combination panel, even where source power lines are overhead.

D. New Shared Electrical Service for Traffic Signal and CCTV

For locations where a single new electrical service is being provided to both a traffic signal controller cabinet and a CCTV cabinet (i.e., two separate circuits from single electrical service), install the new electrical service with two circuit breakers in the disconnect adjacent to the signal controller cabinet in accordance with the "New Electrical Service for Traffic Signal" subsection above. Install new 1" rigid galvanized underground conduits and short risers between the new disconnect and the CCTV cabinet. Route new conductors from the circuit breaker to the cabinets through the new underground rigid conduit and short risers. Permanently label the circuit

◆ **Revision No. 1, April 10, 2017 - This document supersedes version originally issued and sealed by J. Todd Brooks, NCPE No. 017586 on 12/28/2016**

U-4715B**ITS-203****Buncombe County**

breakers to identify which circuit serves the signal controller cabinet and which circuit serves the CCTV cabinet.

E. Modify Existing Electrical Service

At locations shown in the Plans, modify an existing electrical service by one of more of the following methods:

- Replace the existing feeder conductors between the existing disconnect and the traffic signal controller cabinet with new feeder conductors.
- Install a new 15A breaker for CCTV cabinet service in a spare slot in the existing disconnect for a traffic signal controller cabinet to enable the CCTV cabinet to share electrical service with the adjacent traffic signal. Extend electrical service to the CCTV cabinet by routing new feeder conductors to the CCTV cabinet through new 1" rigid galvanized conduit and risers as shown in the Plans. Permanently label the circuit breakers to identify which circuit serves the signal controller cabinet and which circuit serves the CCTV cabinet.
- Install a new grounding system.

Test and upgrade grounding system of the modified electrical service as required to ensure that grounding system complies with the grounding requirements for electrical service in these Project Special Provisions.

F. Disconnect for CCTV Cabinet

At locations indicated in the Plans where a CCTV cabinet shares electrical service with a nearby traffic signal controller cabinet or other ITS device cabinet but is located 100 feet or more away from the shared electrical service, install an additional disconnect on the CCTV pole. Route the feeder conductors from the shared power service disconnect near the traffic signal to this second disconnect on the CCTV pole through new 1" underground conduit and 1" rigid galvanized short risers as shown in the Plans. Install 1" rigid galvanized conduit housing new feeder conductors between the second disconnect on the CCTV pole and the CCTV cabinet.

G. Grounding of Electrical Services

In addition to NEC requirements, test grounding electrode resistance for a maximum of 20 ohms. Furnish and install additional ground rods to grounding electrode system as necessary to meet test requirements. Furnish 5/8" x 10' copper clad steel grounding electrode system (ground rods), #4 AWG solid bare copper conductors, and exothermic welding kits for grounding system installations. Comply with NEC, the *Standard Specifications*, these Project Special Provisions and the Plans.

Modify existing electrical services, as necessary, to meet the grounding requirements of the NEC, these Project Special Provisions and the Plans. Remove any ground rods in the cabinet foundation and install a new grounding electrode system. Cut off abandoned ground rods in the cabinet foundation flush with the foundation surface. Where a grounding electrode system is connected to the electrical service in accordance with the NEC, test grounding electrode resistance for a maximum of 20 ohms. Grounding electrode resistance test must be verified or witnessed by the Engineer or the Engineer's designated representative. Furnish and install

◆ **Revision No. 1, April 10, 2017 - This document supersedes version originally issued and sealed by J. Todd Brooks, NCPE No. 017586 on 12/28/2016**

additional ground rods to grounding electrode system as necessary to meet the requirements of these Project Special Provisions and test requirements.

Follow test equipment's procedures for measuring grounding electrode resistance. When using clamp-type ground resistance meters, readings of less than 1 ohm typically indicate a ground loop. Rework bonding and grounding circuits as necessary to remove ground loop circuits and retest. If a ground loop cannot be identified and removed to allow the proper use of a clamp-type ground resistance meter, use the three-point test method.

Submit a completed Inductive Loop & Grounding Test Form available on the Department's website at:

<https://connect.ncdot.gov/resources/safety/Pages/ITS-and-Signals.aspx>

Install a length of marker tape 6 to 12 inches below finished grade directly over grounding electrodes and conductors.

For locations in downtown Asheville where there is insufficient or no available unpaved areas within the existing right-of-way and grounding electrodes, therefore, must be installed beneath existing sidewalk, replace all sidewalk removed to install the grounding electrodes with in-kind materials in accordance with the requirements for the same in the "Ground Surface Restoration" subsection of the "Equipment Cabinet Foundations" section of these Project Special Provisions.

30.4. MEASUREMENT AND PAYMENT

New electrical service will be measured and paid for as the actual number of complete, functional electrical service locations furnished, installed and tested, regardless of type (i.e., traffic signal only; CCTV cabinet only; shared service for signal and CCTV).

No measurement will be made of risers with weatherheads for electrical service as they will be considered incidental to furnishing and installing a new electrical service.

No measurement will be made of short risers (i.e., from disconnect to underground conduit and from underground conduit to bottom of cabinet), meter bases, meter socket covers, service disconnects, additional circuit breakers in new service disconnects where required, underground conduit between service risers and disconnects/meters, conduit for feeder conductors between the service disconnect and the equipment cabinet, PVC female adapters, acquisition of service fees, service entrance conductors, feeder conductors, ground wire, and any remaining hardware and conduit to connect the electrical service to the cabinet as they will be considered incidental to furnishing and installing new electrical service.

Modify existing electrical service will be measured and paid for as the actual number of existing electrical service locations that have been modified by replacing the existing feeder conductors with new conductors between the disconnect and the controller cabinet as shown in the Plans, by installing an additional 15A breaker for shared electrical service to a CCTV cabinet or by installing a new grounding system. No measurement will be made of electrical service feeder conductors and ground wire as such work is considered incidental to modifying an existing electrical service.

CCTV cabinet disconnect will be measured and paid as the actual number of complete and functional CCTV cabinet disconnects furnished, installed and accepted. No measurement will be made of breakers, feeder conductors, ground wire and any remaining hardware as they will be

◆ **Revision No. 1, April 10, 2017 - This document supersedes version originally issued and sealed by J. Todd Brooks, NCPE No. 017586 on 12/28/2016**

U-4715B**ITS-205****Buncombe County**

considered incidental to furnishing and installing the CCTV cabinet disconnect. No measurement will be made of short risers, underground conduit, PVC female adapters and junction boxes from the existing service point to the CCTV cabinet as such work is considered incidental to furnishing and installing the CCTV cabinet disconnect.

5/8" X 10' grounding electrode (ground rod) will be measured and paid as the actual number of 5/8" copper clad steel ground rods furnished, installed and accepted as part of grounding systems. No separate payment will be made for #4 AWG solid bare copper grounding conductors or exothermic welding kits as they will be considered incidental to furnishing and installing the ground rod(s).

Restoration of sidewalk that is removed to install grounding systems and to install underground conduit between a new electrical service and an equipment cabinet will be measured and paid for in accordance with the "Equipment Cabinet Foundations" section of these Project Special Provisions.

No measurement will be made of pedestal extensions and 6" x 6" wood posts installed for mounting new underground electrical services as they will be considered incidental to furnishing and installing the new electrical service.

No measurement will be made of restoration of unpaved ground surfaces with like materials, including but not limited to backfill, graded stone, seeding and mulching, as this work will be considered incidental to installation of a new electrical service.

The Department will make no payment for a given new electrical service until all repairs to paved and unpaved surfaces damaged/disturbed during the installation the electrical service have been completed and accepted.

Repair and replacement of existing sidewalk will be measured and paid for in accordance with the "Equipment Cabinet Foundations" section of these Project Special Provisions.

Payment will be made under:

| Pay Item | Pay Unit |
|------------------------------------|-----------------|
| New Electrical Service | Each |
| Modify Existing Electrical Service | Each |
| CCTV Cabinet Disconnect | Each |
| 5/8" x 10' Grounding Electrode | Each |

◆ **Revision No. 1, April 10, 2017 - This document supersedes version originally issued and sealed by J. Todd Brooks, NCPE No. 017586 on 12/28/2016**

31. SOLAR POWER ASSEMBLY

31.1. DESCRIPTION

Furnish and install new solar power assembly equipment with equipment cabinets and all necessary hardware in accordance with these Project Special Provisions and the Plans. Comply with the provisions of Section 1700 of the *Standard Specifications*.

31.2. MATERIALS

Furnish a solar power assembly at the locations shown in the Plans consisting of the following:

- Solar Array
- Solar Charge Controller
- Batteries
- Assembly Cabinet
- Concrete Cabinet Pad

A. Solar Array

Furnish solar modules made in North America and that have a minimum 20-year factory warranty. The solar array should have a minimum peak output of 100W. Solar modules must be UL listed, FM Class I, Div II, Group C & D approved. For the solar array, power wiring should be 10-2, stranded copper, double insulated, sunlight resistant, 600V 90C rated cable. The array mount will attach to the side of the CCTV pole with stainless steel fasteners. The array mount must be aluminum alloy or stainless steel. The array must be capable of withstanding 125 mph winds.

B. Solar Charge Controller

Furnish solar charge controllers that are UL listed, a minimum 45A with solid state, low voltage disconnects. Ensure that the solar charge regulator is sealed with internal temperature compensation, lightning protection, reverse polarity protection, and LED indicators. Provide controllers with the capability of three functions: battery charging, load control, and diversion regulation. Controllers must be furnished with fully adjustable DIP switches and RS-232 communications port to adjust the unit's operational modes. Ensure the solar charge regulator is FMS Class I, Groups ABCD and have the CE mark.

C. Batteries

Provide 12V gel electrolyte, non-spillable, maintenance free batteries. Furnish batteries capable of providing power for 10 days without being charged by the Solar Array and Solar Charge Controller. Furnish batteries with a minimum operating temperature of -76° F to 140°F.

D. Solar Power Assembly Cabinet

Furnish a solar power assembly cabinet constructed of 0.125" aluminum with stainless steel hardware. There must be separate compartments for the batteries and the electronics. The enclosures must be NEMA 3R rated and large enough to contain all solar equipment and incidental components, including 20% spare space. Mount the solar power assembly cabinet on a 4" concrete pad.

◆ **Revision No. 1, April 10, 2017 - This document supersedes version originally issued and sealed by J. Todd Brooks, NCPE No. 017586 on 12/28/2016**

U-4715B

ITS-207

Buncombe County

31.3. CONSTRUCTION METHODS

Furnish and install new solar power assemblies. Install solar power equipment as shown in the Plans. Provide wiring, disconnects, and all other required equipment as required by Article 690 of the NEC.

Install solar panel collectors at a height that will prohibit theft and/or vandalism. At a minimum, mount the solar panel collectors 20 feet from ground level. Installation of multiple collector panels shall be approved by the Engineer prior to installation.

Ensure that the maximum resistance between the grounding electrode and all points in the grounding system does not exceed 5 ohms.

In addition to the requirements of the NEC, test grounding electrode resistance at the connection point to the electrical service ground bus for a maximum of 20 ohms. Furnish and install ground rods to the grounding electrode system as necessary to meet the test requirements.

31.4. MEASUREMENT AND PAYMENT

Solar power assembly will be measured and paid as the actual number of solar power assemblies furnished, installed and accepted. No measurement will be made for solar arrays, solar power assembly equipment cabinet, installing breakers, inverters, temperature sensors, concrete cabinet pad, mounting system, grounding system, conduits, risers, wiring, and hardware as these will be considered incidental to furnishing and installing the solar power assembly.

Payment will be made under:

| Pay Item | Pay Unit |
|----------------------|-----------------|
| Solar Power Assembly | Each |

32. 900 MHZ ETHERNET RADIO

32.1. DESCRIPTION

Furnish and install a 900 MHz Ethernet radio system with all necessary hardware and signage in accordance with the Plans and this Project Special Provision to provide a data link between traffic signal controllers. Provide a radio system with a bi-directional, full duplex communications channel between two “line-of-sight” antennas using license free, spread spectrum technology operating in the 902-928 MHz frequency band.

Furnish material and workmanship conforming to the *National Electrical Code* (NEC), the *National Electrical Safety Code* (NESC), Underwriters Laboratories (UL) or a third-party listing agency accredited by the North Carolina Department of Insurance, and all local safety codes in effect on the date of advertisement. Comply with all regulations and codes imposed by the owner of affected utility poles.

32.2. MATERIALS

A. General

Refer to “Pole Line Hardware” subsection in the “Messenger Cable” section of these Project Special Provisions.

Refer to the following articles of the *Standard Specifications*:

| | |
|--------------------------|--------|
| Wire | 1091-2 |
| Signs and Hardware | 1092-1 |
| Retroreflective Sheeting | 1092-2 |

Refer to *Roadway Standard Drawing* No. 1756.01.

B. Standards

Provide Ethernet radios that comply with the following IEEE networking standards for Ethernet communications:

- IEEE 802.1D Spanning Tree Protocol (STP),
- IEEE 802.1Q Virtual Local Area Networks (VLAN Tagging),
- IEEE 802.1X Port-Based Network Access Control,
- IEEE 802.11i Wireless Security,
- IEEE 802.3af Power Over Ethernet,
- RFC 821 – Simple Mail Transfer Protocol (SMTP),
- RFC 2131 – Dynamic Host Configuration Protocol for IPv4,
- RFC 2030 – Simple Network Time Protocol (SNTP).

C. 900 MHz Ethernet Radio Transceivers

Furnish license free 902 – 928 MHz Ethernet radios with antennas, coaxial cable and mounting hardware, and configuration software. Design radio transceivers to work in “point-to-point”, “store and forward repeater”, “point-to-multipoint” and “peer to peer” configurations. Provide radios that can operate as repeaters or access points. Provide radios with both capabilities.

◆ **Revision No. 1, April 10, 2017 - This document supersedes version originally issued and sealed by J. Todd Brooks, NCPE No. 017586 on 12/28/2016**

U-4715B

ITS-209

Buncombe County

Ensure the 900 MHz Ethernet radio transceivers meet the following minimum requirements:

- License free (ISM) spread spectrum radio band (902 – 928 MHz),
- Frequency hopping technology (direct sequence spread spectrum technology is not acceptable),
- Provide user-selectable radio frequency channels (Min. 50) and hopping patterns (Min. 50) that will allow the user to adjust operating characteristics to avoid interference within the intended 902 – 928 MHz frequency range,
- Channel Widths of 5, 10 and 20 MHz,
- Maximum of 8msec. end-to-end latency
- Ethernet interface capable of operating up to 6 to 54 Mbps,
- Built-in store-and-forward (single radio repeater, back-to-back radio set-ups are not allowed to accomplish this function),
- Data encryption:
 - SSID broadcast enable/disable,
 - Firewall for MAC/IP and port filtering
 - 64 bit and 128 bit WEP,
 - 128 bit WPA/WPA2,
 - IEEE 802.1X/RADIUS,
 - TKIP,
 - AES,
- Transmit power: 21 to 24 dBm +/- 1.5 dBm,
- Receiver sensitivity of -90dBm to -71 dBm,
- Front panel LED indicators:
 - Power,
 - Transmit data,
 - Receive data,
 - Data Port Indicators, consisting of at least 3 LED's grouped together representing a Low, Medium or High Signal Strength with regards to the communications link with another targeted radio. Software running on a laptop is not acceptable in meeting this requirement for front panel LED Data Port Indicators.
- Operating temperature of -40 to +165°F at 0 to 95% Humidity.
- Connectors/Ports:
 - Ethernet: 10/100BaseT auto negotiation, bidirectional, full duplex,
 - RS-232 serial console port,
 - Antenna: RP-SMA (female),
- Power supply requirements:
 - Wall adapter:
 - Input Voltage (120 VAC UL/CSA) wall cube plug-in module
 - Output Voltage (6 VDC to 24 VDC)
 - Typical current draw of no greater than 400 mA when powered with 12 VDC input, and transmitting 1 Watt of RF output power.
- Shelf or DIN rail mounted design.

Furnish a Radio Frequency Signal Jumper constructed of an RG-58 Coaxial Cable. On one end of the cable, supply a RF Threaded Connector that is compatible with the radio supplied and on the other end supply a Standard N-Type Male Connector to mate with the lightning arrestor.

◆ **Revision No. 1, April 10, 2017 - This document supersedes version originally issued and sealed by J. Todd Brooks, NCPE No. 017586 on 12/28/2016**

U-4715B**ITS-210****Buncombe County**

Provide the jumper in 6-foot lengths. Ensure that the cable is pre-assembled by a manufacturing facility. Contractor and Vendor assembled cables are not acceptable.

Furnish an Ethernet data interface cable to be installed between the Ethernet radio and either a traffic signal controller or Ethernet edge switch. Ensure cable is a minimum of 6 feet long. Ensure that the cable is assembled in a manufacturing facility. Contractor and/or Vendor assembled cables are not acceptable.

Ensure that installing the Ethernet radio system with a fully functional traffic signal controller does not require any field device modifications with regards to hardware or software.

D. Software

Furnish units with a Windows[®]-based software program that uses a GUI (Graphical User Interface) to provide “remote programming, radio configuration, remote maintenance, diagnostics and spectrum analyzer” features. Ensure the software will operate on Windows[®] 7 or Windows[®] 10. Provide software approved by the Engineer that is designed to function with the approved radio. Provide configuration software that can be upgraded in the future at no additional charge.

Ensure the radio is configurable from a single location (i.e. master radio location) via supplied software (no extra cost). Furnish software supplied with drivers to allow easy set-up with all industry standard traffic signal controllers, including 2070 controllers containing custom software written specifically for the North Carolina Department of Transportation.

E. Directional Antenna (Yagi)

Furnish a directional antenna of welded construction that allows for vertical and horizontal polarization. Furnish 9 dBi Gain or 12 dBi Gain antenna that meets the following minimum specifications:

U-4715B

ITS-211

Buncombe County

Properties of 9 dBi Gain Antenna

| Property | Requirement |
|---|---|
| Frequency Range | 902-928 MHz |
| Nominal Gain | 9 dBi |
| VSWR | 1:1.5 |
| Front to Back Ratio | 18 dB |
| Horizontal Beam Width (at half power points) | 54 degree |
| Vertical Beam Width (at half power points) | 48 degree |
| Power rating, UHF frequency | 100 Watts |
| Lightning Protection | DC ground |
| Termination | Coaxial pigtail with a standard N-Type female connector |
| Impedance | 50 ohms |
| Length | 24" |
| Rated Wind Velocity | 125 mph |
| Rated Wind Velocity (with 0.5 inch Radial Ice) | 100 mph |
| Projected Wind Surface Area (Flat Plane Equivalent) | 0.26 sq ft |
| Number Elements | 5 |

Furnish mounting hardware with the antenna that will secure the antenna to a mounting pipe that has a 1.5" Nominal Pipe Size (approximately 2" OD pipe diameter), as recommended by the manufacturer of the antenna and as approved by the Engineer.

Properties of 13 dBi Gain Antenna

| Property | Requirement |
|---|---|
| Frequency Range | 902 – 928 MHz |
| Nominal Gain | 13 dBi |
| Front to Back Ratio | 20 dB |
| Horizontal Beam Width (at half power points) | 40 degree |
| Vertical Beam Width (at half power points) | 35 degree |
| Power rating, UHF frequency | 200 Watts |
| Lightning Protection | DC Ground |
| Termination | Coaxial pigtail with a Standard N-Type Female Connector |
| Impedance | 50 ohms |
| Length | 53" |
| Rated Wind Velocity | 125 mph |
| Rated Wind Velocity (with 0.5 inch Radial Ice) | 100 mph |
| Projected Wind Surface Area (Flat Plane Equivalent) | 0.46 sq ft |
| Number Elements | 13 |

◆ **Revision No. 1, April 10, 2017 - This document supersedes version originally issued and sealed by J. Todd Brooks, NCPE No. 017586 on 12/28/2016**

U-4715B

ITS-212

Buncombe County

Furnish mounting hardware with the antenna that will secure the antenna to a mounting pipe that has a 1.5" Nominal Pipe Size (approximately 2" OD pipe diameter), as recommended by the manufacturer of the antenna and as approved by the Engineer.

F. Omni Antenna

Furnish an omni antenna of solid, single piece construction that meets the following minimum specifications:

Properties of Omni Antenna

| Property | Requirement |
|--------------------------------|----------------------------------|
| Frequency Range | 902-928 MHz |
| Nominal Gain | Typical gains of 9 dBi |
| Termination | Standard N-Type female connector |
| Impedance | 50 ohms |
| VSWR | 1.5:1 |
| Polarization | Linear |
| Horizontal Beam Width | 360 degrees |
| Vertical Beam Width | 11 degrees |
| Lightning Protection | DC ground |
| Power Rating, UHF Frequency | 50 Watts |
| Length | 57" |
| Rated Wind Velocity | 125 mph |

Furnish mounting hardware with the antenna that will secure the antenna to a mounting pipe that has a 1.5" Nominal Pipe Size (approximately 2" OD pipe diameter), as recommended by the manufacturer of the antenna and as approved by the Engineer.

G. Panel Antenna

Furnish a panel antenna of solid, single piece construction that meets the following minimum specifications:

Properties of Panel Antenna

| Property | Requirement |
|-----------------|----------------------------------|
| Frequency Range | 902-928 MHz |
| Nominal Gain | Typical gains of 8 dBi |
| Termination | Standard N-Type Female Connector |
| Impedance | 50 Ohms |
| VSWR | <1.5:1 |

◆ **Revision No. 1, April 10, 2017 - This document supersedes version originally issued and sealed by J. Todd Brooks, NCPE No. 017586 on 12/28/2016**

U-4715B

ITS-213

Buncombe County

Properties of Panel Antenna

| Property | Requirement |
|-----------------------------|------------------------|
| Polarization | Vertical or Horizontal |
| Horizontal Beam Width | 75 Degrees |
| Vertical Beam Width | 65 Degrees |
| Lightning Protection | DC Ground |
| Power Rating, UHF Frequency | 50 Watts |
| Size | Nominally 9" X 9" X 1" |
| Rated Wind Velocity | 125 mph |

Furnish mounting hardware with the antenna that will secure the antenna to a mounting pipe that has a 1.5" Nominal Pipe Size (approximately 2" OD pipe diameter), as recommended by the manufacturer of the antenna and as approved by the Engineer.

H. Antenna Mounting Hardware Kit

Furnish an antenna mounting kit to support the antenna when attached to a metal pole, mast arm or wood pole.

Ensure the Antenna Mounting Hardware Kit includes at least one 96" galvanized steel cable with a stainless steel bolt, nut and lock washer assembly on each end. Ensure the pole base plate accepts a 1-1/2" NPT aluminum pipe, and provides a surface that is at least 6-3/4" long x 4-1/4" to provide contact with the pole. Ensure the pole base plate is designed to allow both ends of the 96" galvanized cables to be secured and tightened to the base plate. Provide a 90 degree elbow with internal threads on both ends to accommodate 1-1/2" NPT aluminum pipes. Provide a 1-1/2" x 18" long aluminum pipe threaded on both ends and a 1-1/2" x 24" aluminum pipe threaded on one end with an end cap.

I. Coaxial Cable

Furnish 400 Series cable to provide a link between the antenna and the lightning arrester that meets the following minimum specifications:

U-4715B

ITS-214

Buncombe County

Properties of Coaxial Cable

| Property | Requirement |
|-----------------------------------|--|
| Attenuation (dB/100 ft) @ 900 MHz | 3.9 dB |
| Power Rating @ 900 MHz | 0.58 kW |
| Center Conductor | 0.108" diameter Copper Clad Aluminum |
| Dielectric: Cellular PE | 0.285" diameter |
| Shield | Aluminum Tape – 0.291" diameter Tinned Copper Braid – 0.320" diameter |
| Jacket | Black UV protected polyethylene |
| Bend radius | 1" with less than 1 ohm impedance change at bend |
| Impedance | 50 ohms |
| Capacitance per foot | 23.9 pF/ft |
| End connectors | Standard N-Type Male Connectors on both ends |

J. Standard N-Type Male Connector

Furnish standard N-Type male connector(s) of proper sizing to mate with the 400 series coaxial cable and use a crimping method to secure the connector to the coaxial cable. Furnish a connector that meets the following minimum requirements:

- 1) Center contact: Gold plated beryllium copper (spring loaded, non-solder),
- 2) Outer contact: Silver plated brass,
- 3) Body: Silver plated brass,
- 4) Crimp sleeve: Silver plated copper,
- 5) Dielectric: Teflon PTFE,
- 6) Waterproofing sleeve: Adhesive lined polyolefin – heat shrink, and
- 7) Attachment Size: Crimp Size 0.429" (minimum) hex.
- 8) Electrical Properties:
 - a) Impedance: 50 ohms,
 - b) Working voltage: 1000 vrms (max),
 - c) Insertion loss: $0.1 \times \sqrt{F_{GHz}}$, and
 - d) VSWR: 1.25:1 (max) up to 3GHz.

K. Coaxial Cable Shield Grounding and Weatherproofing Kits

Furnish a coaxial cable shield grounding kit containing components that will adequately bond and ground the cable shield to the pole ground. Ensure the grounding kit complies with MIL-STD-188-124A for coaxial cable and protects the cable from lightning currents in excess of 200kA. Ensure each kit is supplied, as a minimum, with the following:

- Preformed strap: 24 gauge copper strap that is a minimum of 1-5/8 inch long and is sized to mate with the 400 series coaxial cable,
- Tensioning hardware: Copper nuts and lock washers,
- Grounding lead cable: #6 AWG, stranded, insulated copper wire

◆ **Revision No. 1, April 10, 2017 - This document supersedes version originally issued and sealed by J. Todd Brooks, NCPE No. 017586 on 12/28/2016**

Furnish a weatherproofing kit containing components that will protect the coaxial cable shield grounding system against the ingress of moisture and prevent vibrations from loosening the connections. Ensure the weatherproofing kit is supplied, as a minimum, with the following:

- Butyl mastic tape: 3-3/4 inches wide by 24 inches long (approximately),
- Electrical tape: 2 inches wide by 20 inches long (approximately)

L. Lightning Arrestor

Furnish a lightning arrestor installed in line between each antenna and its designated radio inside the equipment cabinet that complies with the requirements listed in the table below. Furnish a lightning arrestor with multi-strike capability, low strike throughput energy, flange mount and bulkhead mount options and a standard N-Type female connector on both the surge-side and protected-side connectors.

Properties of Lightning Arrestor

| Property | Requirement |
|---------------------|--|
| Filter Type | DC Block (non gas tube design) |
| Surge | 20kA, 800MHz to 2.0GHz \leq 1.1 : 1 VSWR 18kA, 800MHz to 2.3GHz \leq 1.1 : 1 VSWR 18kA, 700MHz to 2.7GHz \leq 1.2 : 1 VSWR |
| Insertion loss | \leq 0.1 dB over frequency range |
| Max power | 500 w @ 920MHz (750 W @ at 122° F) |
| RF power | 300 Watts |
| Let through voltage | \leq \pm 3 Volts for 3kA @ 8/20 μ s Waveform |
| Throughput energy | \leq 0.5 μ J for 3kA @ 8/20 μ s Waveform |
| Temperature | -40 to 185° F Storage/Operating 122° F |
| Vibration | 1G at 5 Hz up to 100Hz |
| Unit impedance | 50 Ω |
| VSWR | 1.1:1 |
| Frequency range | 800 MHz to 2200 MHz |

M. Disconnect Switch

Where an antenna is mounted on a joint-use pole, furnish a double pole, single throw snap switch in a weatherproof outlet box with cover, suitable for use in wet locations. Ensure outlet box and cover support a lockout tag device. Ensure outlet box includes one ½-inch hole in back of box. Furnish mounting hardware, sealing gaskets and lockout tag. On NCDOT and City-owned poles, the disconnect switch is not required and may be omitted.

N. Warning Signs(s) and Decal(s)

Where an antenna is mounted on a joint-use pole, furnish an “RF Warning Sign” and “Decal” in accordance with *Roadway Standard Drawing* No. 1736.01, Sheets 3 and 4 of 5. Furnish stainless steel banding hardware or other attachment method approved by the Engineer to secure the sign to either metal or wood poles. On NCDOT or City-owned poles, the warning signs and decals are not required and may be omitted.

◆ **Revision No. 1, April 10, 2017 - This document supersedes version originally issued and sealed by J. Todd Brooks, NCPE No. 017586 on 12/28/2016**

U-4715B

ITS-216

Buncombe County

O. Pole-Mount Radio Cabinet

To house radio equipment, fiber-optic interconnect center, power supplies and surge protection for radios that are not located at a traffic signal or CCTV camera, furnish a Type 1 flasher/detector cabinet fabricated from 0.125" thick 5052-H32 marine grade aluminum with approximate dimensions of 14" x 14" x 11" but not to exceed 16" x 14" x 14". Provide a flasher/detector cabinet that is on the ITS & Signals QPL.

Provide a cabinet of compact design equipped with power supply but of sufficient size to accommodate radio 900 MHz Ethernet radio electronics and a cabinet-mounted interconnect center for termination of a fiber-optic drop cable. Furnish at cabinet with a front door with permanent neoprene door gasket, a continuous stainless steel hinge and single-point latching that use a Corbin No. 2 lock. Provide two keys for each cabinet. Equip the cabinet with screened louvers for ventilation. Provide all hardware and brackets necessary to mount the cabinet to a wood utility pole.

32.3. CONSTRUCTION METHODS**A. General**

The locations and types of antennas shown in the Plans are the recommend locations and types based upon testing and analysis performed during the design phase of the project. Site conditions may have changed since the initial tests were performed. It is ultimately the Contractor's responsibility to confirm through on-site field testing the types and locations of antennas for each wireless communications link and to provide alternate antenna types and locations if required and subject to the Engineer's approval to achieve a fully functional, reliable wireless communications system for this project.

Perform a radio path site survey test before ordering and installing any equipment.

Ensure the test evaluates the Signal Strength (dBm), Fade Margin (dB), Signal-to-Noise Ratio, Data Integrity (poll test), and a complete frequency spectrum scan. Ensure the radio path site survey test is performed using the supplied brand of radio equipment and type of antenna to be deployed at each location. During the initial radio path signal strength test it may be determined that a repeater station may be necessary to complete the intended link. Provide the test results to the Engineer for review and approval.

Submit copies of the test results and colored copies of the frequency spectrum scan along with an electronic copy of this information. The Engineer will approve final locations of antennas and any necessary repeater stations as well as the type of antenna use at each location. Install a coaxial cable, a power divider, and additional antenna locations where it is determined that a dual antenna configuration is necessary to accommodate communications in multiple directions.

At certain locations it may be necessary to integrate the radio system with a fiber-optic system. Follow the details shown in the fiber-optic splice plans.

Refer to and comply with *Roadway Standard Drawing* No. 1736.01, as amended and supplemented by the special details in the Plans. Use a 1" riser with heat-shrink tubing in lieu of a 2-inch riser with heat-shrink tubing to convey the coaxial cable for the antenna unless the Plans indicate otherwise..

◆ **Revision No. 1, April 10, 2017 - This document supersedes version originally issued and sealed by J. Todd Brooks, NCPE No. 017586 on 12/28/2016**

U-4715B

ITS-217

Buncombe County

B. Antenna

Install the antenna in such a manner that avoids conflicts with other utilities (separation distances in accordance with the guidelines of the NESC) and as specified in the antenna manufacturer's recommendations. Secure the antenna mounting hardware to the pole and route the coaxial cable such that no strain is placed on the N-Type Male coaxial connectors. On wood pole installations, bond the antenna mounting hardware to the pole ground using # 6 AWG bare copper wire using split bolt or compression type fitting. Install two antennae at a repeater site with separate radios.

C. Cabling

Install the coaxial cable shield grounding system by carefully removing the outer jacket of the coaxial cable without damaging the cable shield. Install the shield grounding system following the cable manufacturer's recommendations. Install and weatherproof the connection using the appropriate weatherproofing materials and following the manufacturer's recommendations. On wood poles, secure the #6 AWG grounding lead cable to the pole ground using split bolt or compression type fitting or an Engineer approved method. On metal poles, secure the #6 AWG grounding lead cable to the pole using an Engineer approved method.

Do not exceed the 1-inch bend radius of the coaxial cable as it traverses from the cabinet to the antenna assembly. Connect the lightning arrester to the coaxial cable in the equipment cabinet. Properly ground and secure the arrester in the cabinet.

Under a separate City project by others, the City of Asheville will be replacing aged existing metal poles with mast arms with new metal poles with mast arms at the following intersections along Patton Avenue in downtown Asheville:

| Signal Inventory No. | Intersection Name |
|----------------------|---|
| COA-111 | Patton Avenue at S. French Broad Avenue |
| COA-110 | Patton Avenue at Otis Street |
| COA- 109 | Patton Avenue at Asheland Avenue |
| COA-108 | Patton Avenue at Coxe Avenue |

At the locations listed above, coil and store inside the controller cabinet a minimum of 30 feet of additional coaxial cable for each antenna at that intersection to facilitate the relocation of the antenna(s) to the proposed new metal pole(s) with mast arm(s) by others at a later date.

D. Cabinet and Electrical Power Wiring

Fasten all wiring and harness supports to the cabinet with screws or other removable mechanical means. Do not use adhesives.

Do not locate terminals on the underside of the shelf or at other places where they are not readily visible and accessible, or where they may be a hazard to personnel. Provide a clear plastic guard for exposed 120 VAC terminals on the power panel.

Permanently label all cables entering the cabinet. Ensure the power supply for the radio system is **NOT** connected to the GFCI receptacle circuit located in the cabinet. Place a copy of

◆ **Revision No. 1, April 10, 2017 - This document supersedes version originally issued and sealed by J. Todd Brooks, NCPE No. 017586 on 12/28/2016**

U-4715B

ITS-218

Buncombe County

all manufacturer equipment specifications and instruction and maintenance manuals in the equipment cabinet.

E. Disconnect Switch

At locations where the antenna is mounted on a joint-use pole, install a double pole, snap switch to remove power from the Ethernet radio transceiver system. Comply with *Roadway Standard Drawing* No. 1736.01, Sheet 1 of 5. Do not mount weatherproof box on the traffic signal cabinet door. Drill a hole in the side of the traffic signal cabinet. Mount the outlet box over the hole using a ½-inch chase nipple and bushings. Ensure sealing gaskets are in place and no water can enter the cabinet. Securely mount the weatherproof outlet box with additional mounting screws. Bond the outlet box to the equipment ground bus. Run the power supply cord of the Ethernet radio unit into the outlet box and connect to switch. Securely attach power supply cord to equipment rack. Install disconnect switch with lockout tag cover. The disconnect switch is required where the antenna is mounted on a joint-use pole. If the antenna is mounted on an NCDOT or City-owned pole, the disconnect switch is not required and may be omitted.

Do not install the power supply for the radio in a GFCI protected outlet.

F. Warning Sign(s) and Decal(s)

At locations where the antenna is mounted on a joint use pole, mount the warning sign to the pole as shown on *Roadway Standard Drawing* No. 1736.01, Sheet 2 of 5. Ensure there are no conflicts between the warning sign and surrounding utilities. Mount warning sign to be easily viewed. Do not mount warning sign under pole grounds or conduit.

Clean and remove any dirt or oil on traffic cabinet before placing decal. Place decal adjacent to the disconnect switch located on the outside of traffic cabinet as shown on *Standard Drawing* No. 1736.01, Sheet 1 of 5.

The RF warning signs and decals are required when antennas are mounted on joint-use poles. If the antenna is mounted on an NCDOT or City-owned pole, the warning signs and decals are not required and may be omitted.

G. Pole-Mount Radio Cabinet

Mount the radio cabinet on wood pole at a height of 4 feet above the ground measured to the center of the cabinet. Position the cabinet on the pole so that it does not overhang an adjacent sidewalk or pedestrian path. Install conduit/riser containing fiber-optic communications cable(s) and terminate the communications cable in the cabinet mounted interconnect center. Connect the Ethernet radio to the appropriate connectors on the interconnect center patch panel using SMFO jumpers. Install electrical service into the bottom of the cabinet. Attach riser conveying the coaxial cable to the antenna on the pole to the bottom of the cabinet and terminate the coaxial cable on the Ethernet radio inside the cabinet.

32.4. MEASUREMENT AND PAYMENT

900MHz Ethernet Radio will be measured and paid as the actual number of Ethernet radios furnished, installed and accepted according to following conditions: 80% of the payment will be made upon acceptance of the installed radio system and the remaining 20% of the payment will be made following final acceptance (including completion of the 60-day Observation Period). This item includes the appropriate sized antenna(e), antenna mounting hardware, radio, power supplies and power cords, disconnect/snap switch, signs, decals, data interface cable, coaxial

◆ **Revision No. 1, April 10, 2017 - This document supersedes version originally issued and sealed by J. Todd Brooks, NCPE No. 017586 on 12/28/2016**

U-4715B**ITS-219****Buncombe County**

cable (including storage of slack cable), lightning arrestor, radio frequency jumper, coaxial cable power divider (splitter), coaxial cable connectors, coaxial cable shield grounding system with weatherproofing, labeling, any integration between the radio system and a fiber-optic network if necessary, installation materials and configuration software necessary to complete this work, including the radio path site survey and warranties.

Pole-mount radio cabinet will be measured as and paid as the actual number of pole mounted radio cabinets furnished, installed and accepted. No measurement will be made of pole mounting hardware, brackets, banding and fasteners needed to mount the cabinet on the pole as such items will be considered incidental to furnishing and installing a pole-mount radio cabinet. Furnishing and installing SMFO jumpers will be considered incidental to the 900 MHz radio.

Riser assemblies will be measured and paid for separately in accordance with the "Riser Assemblies" section of these Project Special Provisions.

Payment will be made under:

| Pay Item | Pay Unit |
|--------------------------|-----------------|
| 900MHz Ethernet Radio | Each |
| Pole-Mount Radio Cabinet | Each |

33. 2.4 GHZ ETHERNET RADIO

33.1. DESCRIPTION

Furnish and install a 2.4 GHz Ethernet radio system with all necessary hardware in accordance with the Plans and this Project Special Provision to provide video and data links between CCTV cameras on the Interstates in the area as shown in the Plans. Provide a radio system with a bi-directional, full duplex communications channel between multiple “near line-of-sight” antennas using licensed, spread spectrum technology operating in the 2.4 GHz unlicensed frequency band. The wireless Ethernet radio shall be a 2.4 GHz solution with a 12 dBi Yagi or 12 dBi omni-directional antenna as shown in the Plans or an Engineer approved equivalent.

Furnish material and workmanship conforming to the *National Electrical Code* (NEC), the *National Electrical Safety Code* (NESC), Underwriters Laboratories (UL) or a third-party listing agency accredited by the North Carolina Department of Insurance, and all local safety codes in effect on the date of advertisement. Comply with all regulations and codes imposed by the owner of affected utility poles.

A. Standards

Provide Ethernet radios that comply with the following IEEE networking standards for Ethernet communications:

- 802.11a/b/g/n Wireless LAN,
- IEEE 802.1D Spanning Tree Protocol (STP),
- IEEE 802.1Q Virtual Local Area Networks (VLAN Tagging),
- IEEE 802.1w Rapid Spanning Tree Protocol,
- IEEE 802.11i Wireless Security,
- IEEE 802.3 10BaseT,
- IEEE 802.3ab 100BaseT,
- IEEE 802.3af Power Over Ethernet,
- RFC 821 – Simple Mail Transfer Protocol (SMTP),
- RFC 2131 – Dynamic Host Configuration Protocol for IPv4,
- RFC 2030 – Simple Network Time Protocol (SNTP).

B. General

Wireless Ethernet Radios at CCTV Sites

To provide an Ethernet network signal connection to other device locations, furnish and install wireless Ethernet radios in a point-to-point (P2P), point-to-multipoint (P2MP) or repeater configuration at the following locations:

| No. | Corridor | Location | Fiber Access Point | Ethernet Radio Configuration | Antenna Type |
|-----|----------|-----------|--------------------|------------------------------|--------------|
| 1 | I-26 | Pond Road | Yes | PTP | Yagi* |
| 2 | I-40 | I-240 | No | Repeater | Omni* |
| 3 | I-40 | MM 46 | No | PTP | Yagi* |
| 4 | I-40 | MM 44.5 | No | PTP | Yagi* |

* Based on the results of the radio path site survey as specified in subsection entitled "Site Survey" under "Construction Methods" below, the location, antenna type and radio configuration may be subject to change. In these instances, the Contractor shall install the appropriate antenna type and configure each radio to achieve the maximum signal transfer.

At certain locations it will be necessary to integrate the radio system with a fiber-optic system. Follow the details shown in the fiber-optic splice plans.

33.2. MATERIALS

A. Ethernet Radio

The Ethernet radio shall be 2.412 to 2.462 GHz with a 12dBi Yagi or omni-directional antenna or an Engineer approved equivalent at locations as shown in the Plans. The 2.4 GHz Ethernet radio shall enable high-speed long range outdoor point-to-point, point-to-multipoint and repeater communications links and shall be suited for installations subject to harsh environments.

The wireless outdoor 2.4 GHz Ethernet radio shall include the radio, power supply, cabling and connectors, and a surge protection.

Ensure the Ethernet radio meets the following minimum requirements:

Radio Specifications

- Multiple Frequency Bands: 2.412 to 2.462 GHz Unlicensed Band
- Channels: 11
- Frequency Selection: Dynamic
- Total System EIRP and radio output power: Radio output power Max: 18dBm (Set to local regulatory requirements to comply with transmit, conducted EIRP power limits)
- Data Rate: 1 to 54 Mbps
- Transmit Rates: 802.11B: 1-11 Mbps, 802.11a/g: 6-54 Mbps, and 802.11n: 6.5-300 Mbps
- Transmit Power: 802.11b: 18 dBm, 802.11g: 15-18 dBm, 802.11a: 14-17 dBm

◆ **Revision No. 1, April 10, 2017 - This document supersedes version originally issued and sealed by J. Todd Brooks, NCPE No. 017586 on 12/28/2016**

U-4715B**ITS-222****Buncombe County**

- Receiver Sensitivity: 92 to -84 dBm at 802.11b, -87 to -70 dBm at 802.11g, -87 to -70 dBm at 802.11a,
- Wireless Modulation: Orthogonal Frequency Division Multiplexing (OFDM)
- Operating Modes: Backhaul (point-to-point) Point-to-multipoint and Repeater
- Security/Authentication and Encryption: AES, 64 and 128 bit WEP Encryption, WPA, WPA2, TKIP, SSID broadcast enable/disable, firewall for MAC/IP/Port-based filtering, IEEE 802.1X RADIUS

Configuration and Management

- Configuration Utility: Remote SSH, SNMP, FTP
- Software Upgrades: FTP download
- Diagnostics Tools: Antenna Alignment, Bandwidth, and Frequency Usage
- Real-time Link Monitoring: Secure Management Interface - Real-time signal strength, authentication data, system uptime, data rate, channel selection
- Electrical Power Input: 120 VAC input. low voltage DC with maximum power consumption of 9W.
- Power Output: 1 Amp at 18VDC
- Mechanical Dimensions: 13 in x 13 in x 13 in
- Weight: Less than 6 pounds.

Environmental

- Radio Operating Temperature: -30°C to 60°C. Weather protected outdoor units
- Radio Operating Humidity: 5% to 95% non-condensing

Compliance and Certification

- Regulations: FCC Part 90
- Safety: UL - Canada, USA, CE

The wireless 2.4 GHz Ethernet radio shall be capable of being configured in point-to-point, point-to-multipoint or repeater modes of operation.

◆ **Revision No. 1, April 10, 2017 - This document supersedes version originally issued and sealed by J. Todd Brooks, NCPE No. 017586 on 12/28/2016**

U-4715B

ITS-223

Buncombe County

B. Directional Antenna

Furnish a directional antenna of solid, single piece construction that meets the following minimum specifications:

Properties of Directional Antenna

| Property | Requirement |
|-----------------------------|----------------------------------|
| Frequency range | 2400- 2500 MHz |
| Nominal gain | Typical gain of 12 dBi |
| Termination | Standard N-Type female connector |
| Impedance | 50 ohms |
| Front to Back Ratio | 20 dB |
| VSWR | 1:1.5 |
| Polarization | Horizontal or Vertical |
| Horizontal Beam Width | 16 degrees |
| Vertical Beam Width | 21 degrees |
| Lightning protection | DC ground |
| Power rating, UHF frequency | 100 Watts |
| Dimensions | 12:” x 15” nominal |
| Rated wind velocity | 125 mph |

C. Omni Antenna

Furnish an omnidirectional antenna of solid, single piece construction that meets the following minimum specifications:

Properties of Omnidirectional Antenna

| Property | Requirement |
|-----------------------|----------------------------------|
| Frequency range | 2400- 2500 MHz |
| Nominal gain | Typical gain of 12 dBi |
| Termination | Standard N-Type female connector |
| Impedance | 50 ohms |
| VSWR | 1:1.5 |
| Polarization | Linear |
| Horizontal Beam Width | 360 degrees |
| Vertical Beam Width | 6 degrees |
| Lightning protection | DC ground |

◆ **Revision No. 1, April 10, 2017 - This document supersedes version originally issued and sealed by J. Todd Brooks, NCPE No. 017586 on 12/28/2016**

U-4715B

ITS-224

Buncombe County

Properties of Omnidirectional Antenna

| Property | Requirement |
|-----------------------------|--------------------|
| Power rating, UHF frequency | 100 Watts |
| Length | 57" |
| Rated wind velocity | 125 mph |

D. Coaxial Cable

Furnish LMR-400 DB and LMR-600 DB waterproof cable as shown in the Plans and required by these Project Special Provisions to provide a link between the antenna and the lightning arrestor that meets the following minimum specifications:

Properties of 400 Series Coaxial Cable

| Property | Requirement |
|-----------------------------------|--|
| Attenuation (dB/100 ft) @ 2.4 GHz | 6.6 dB |
| Average Power rating @ 2.4 GHz | 0.34 kW |
| Center conductor | 0.108" diameter Copper Clad Aluminum |
| Dielectric: Cellular PE | 0.285" diameter |
| Shield | Aluminum Tape – 0.291" diameter Tinned Copper Braid – 0.320" diameter |
| Jacket | Black UV protected polyethylene |
| Bend radius | 1" with less than 1 ohm impedance change at bend |
| Impedance | 50 ohms |
| Capacitance per foot | 23.9 pF/ft |
| End connectors | Standard N-Type Male Connectors on both ends |

Properties of 600 Series Coaxial Cable

| Property | Requirement |
|-----------------------------------|--|
| Attenuation (dB/100 ft) @ 2.4 GHz | 4.4 dB |
| Average Power rating @ 2.4 GHz | 0.53 kW |
| Center conductor | 0.176" diameter Copper Clad Aluminum |
| Dielectric: Cellular PE | 0.455" diameter |
| Shield | Aluminum Tape – 0.461" diameter Tinned Copper Braid – 0.490" diameter |
| Jacket | Black UV protected polyethylene |
| Bend radius | 1" with less than 1 ohm impedance change at bend |
| Impedance | 50 ohms |
| Capacitance per foot | 23.4 pF/ft |
| End connectors | Standard N-Type male connectors on both ends |

◆ **Revision No. 1, April 10, 2017 - This document supersedes version originally issued and sealed by J. Todd Brooks, NCPE No. 017586 on 12/28/2016**

U-4715B

ITS-225

Buncombe County

E. Standard N-Type Male Connector

Furnish standard N-Type male connector(s) of proper sizing to mate with the 400 and 600 series coaxial cables and use a crimping method to secure the connector to the coaxial cable. Furnish a connector that meets the following minimum requirements:

- Center contact: Gold plated beryllium copper (spring loaded, non-solder),
- Outer contact: Silver plated brass,
- Body: Silver plated brass,
- Crimp sleeve: Silver plated copper,
- Dielectric: Teflon PTFE,
- Waterproofing sleeve: Adhesive lined polyolefin – heat shrink, and
- Attachment Size: Crimp Size 0.429” (minimum) hex.
- Electrical Properties:
 - Impedance: 50 ohms,
 - Working voltage: 1000 vrms (max),
 - Insertion loss: $0.1 \times \sqrt{F_{GHz}}$, and
 - VSWR: 1.25:1 (max) up to 3GHz.

F. Coaxial Cable Shield Grounding and Weatherproofing Kits

Furnish a coaxial cable shield grounding kit containing components that will adequately bond and ground the cable shield to the pole ground. Ensure the grounding kit complies with MIL-STD-188-124A for coaxial cable and protects the cable from lightning currents in excess of 200kA. Ensure each kit is supplied, as a minimum, with the following:

- Preformed strap: 24 Gauge copper strap that is a minimum of 1-5/8 inch long and is sized to mate with the 400 series coaxial cable,
- Tensioning hardware: Copper nuts and lock washers,
- Grounding lead cable: #6 AWG, stranded, insulated copper wire

Furnish a weatherproofing kit containing components that will protect the coaxial cable shield grounding system against the ingress of moisture and prevent vibrations from loosening the connections. Ensure the weatherproofing kit is supplied, as a minimum, with the following:

- Butyl mastic tape: 3-3/4 inches wide by 24 inches long (approximately),
- Electrical tape: 2 inches wide by 20 inches long (approximately)

G. Surge Suppression

Provide surge protection in the traffic signal controller cabinet. All surge protection devices shall have an ambient operating temperature of -40 degrees F to 165 degrees F with 95 percent non-condensing relative humidity. All surge protection devices shall comply with UL 497A for paired data communications.

◆ **Revision No. 1, April 10, 2017 - This document supersedes version originally issued and sealed by J. Todd Brooks, NCPE No. 017586 on 12/28/2016**

U-4715B

ITS-226

Buncombe County

Provide specialized surge protection devices at the supply side of all low voltage connections to the wireless Ethernet radios. These connections include Ethernet data cables that comply with EIA requirements.

These specialized surge protection units shall be UL listed according to the UL 497A. The minimum surge current rating for the surge protection shall be 2,000 amps for data and telecommunications.

H. Pole-Mounting Hardware

Provide all hardware and mounting brackets required to mount the antennas and RF antenna warning sign (where required) on metal and wood poles as required by the Plans. Attach antennas and signs to poles using stainless steel banding hardware and clamps. Submit catalog cuts/manufacturer's literature for banding hardware and clamps to the Engineer for approval.

33.3. CONSTRUCTION METHODS

A. General

The locations and types of antennas shown in the Plans are the recommend locations and types based upon testing and analysis performed during the design phase of the project. Site conditions may have changed since the initial tests were performed. It is ultimately the Contractor's responsibility to confirm through on-site field testing the types and locations of antennas for each wireless communications link and to provide alternate antenna types and locations if required and subject to the Engineer's approval to achieve a fully functional, reliable wireless communications system for this project.

B. Site Survey

Perform a radio path site survey test before ordering and installing any equipment.

Ensure the test evaluates the Signal Strength (dBm), Fade Margin (dB), Signal-to-Noise Ratio, Data Integrity (poll test), and a complete frequency spectrum scan. Ensure the radio path site survey test is performed using the supplied brand of radio equipment and type of antenna to be deployed at each location. During the initial radio path signal strength test it may be determined that a repeater station may be necessary to complete the intended link. Provide the test results to the Engineer for review and approval. Submit copies of the test results and color copies of the frequency spectrum scan along with an electronic copy of this information. The Engineer will approve final locations of antennas and any necessary repeater stations as well as the type of antennas used for each location. If required, install an antenna splitter cable at locations where it is determined that a dual antenna configuration is necessary to accommodate communications in multiple directions.

C. Configuration

Set up the wireless Ethernet radio for operation in accordance with the manufacturer's recommendations. Configure the radios as point-to-point, point-multipoint or repeaters as appropriate. Configure them to use the frequencies found to minimize interference. Align antennas to receive the maximum signal transfer. Implement strong encryption and any other security features offered or as requested by the Engineer. Test to ensure that the radios function as intended.

◆ **Revision No. 1, April 10, 2017 - This document supersedes version originally issued and sealed by J. Todd Brooks, NCPE No. 017586 on 12/28/2016**

U-4715B

ITS-227

Buncombe County

D. Software

Furnish units with a Windows® compatible software program that uses a GUI (Graphical User Interface) to provide “remote programming, radio configuration, remote maintenance, diagnostics and spectrum analyzer” features. Provide software approved by the Engineer that is designed to function with the approved radio. Provide configuration software that can be upgraded in the future at no additional charge to the City/Department.

Ensure the wireless Ethernet radio transceiver is configurable from a single location (i.e. either end of the radio link) via supplied software (no extra cost to the City/Department).

E. General Requirements for Metal Pole Locations

At most of the intersections in the proposed 2.4 GHz Ethernet radio system, the traffic signals and controller cabinets are mounted on metal poles with mast arm and streetlight poles owned by Duke Energy. Coordinate all work related to the mounting of antennas and routing of antenna cables on these metal poles with Duke Energy. Comply with Duke Energy’s requirements for conducting work on these metal poles.

Be advised that unfused electrical service conductors may be present in transformer bases of the metal poles as well as routed vertically inside the pole to streetlights mounted at the top of the pole. Take care to ensure that antenna cables do not come in contact with such electrical wiring inside the transformer base and inside the pole and install non-metallic flexible conduit to shield the antenna cable from such electrical conductors. Take necessary precautions so that workers do not contact the service conductors while installing the antenna cables.

Prior to performing installing antennas and antenna cables, thoroughly investigate each site where antennas are proposed for mounting on the Duke-owned metal poles to become familiar with the unique conditions associated with each site and to ascertain the scope of the work required at each location. Develop a site-specific work plan as needed to address unique conditions encountered at each site.

Do not create any new holes or enlarge any existing holes in the metal poles, mast arms and transformer bases.

F. Antenna

Install the antenna in such a manner that avoids conflicts with other utilities (separation distances in accordance with the guidelines of the NESC) and as specified in the antenna manufacturer’s recommendations. Refer to the special details in the Plans for antenna mounting and cable routing details. Secure the antenna mounting hardware to the pole and route the Ethernet cable such that no strain is placed on the RG-45 connectors. On wood pole installations, bond the antenna mounting hardware to the pole ground using # 6 AWG bare copper wire using split bolt or compression type fitting. Install two antennae at a repeater site with a low-loss coaxial cable and, if required, an antenna cable splitter. If used, secure the antenna cable splitter to pole, using Engineer-approved non-intrusive methods to attach them securely to metal poles. Examples of non-intrusive attachment methods, subject to the Engineer’s review and approval, include: black UV and weather resistant cable ties designed for outdoor use; industrial grade black hook-and-loop fastener systems designed for outdoor use; and black, heavy-duty, double-sided adhesive foam mounting squares designed to be permanent and weather resistant for outdoor use.

◆ **Revision No. 1, April 10, 2017 - This document supersedes version originally issued and sealed by J. Todd Brooks, NCPE No. 017586 on 12/28/2016**

Secure the antenna to the pole using stainless steel banding hardware or a method approved by the Engineer.

G. Antenna Cabling

Install the coaxial cable shield grounding system by carefully removing the outer jacket of the coaxial cable without damaging the cable shield. Install the shield grounding system following the cable manufacturer's recommendations. Install and weatherproof the connection using the appropriate weatherproofing materials and following the manufacturer's recommendations. On wood poles, secure the #6 AWG grounding lead cable to the pole ground using split bolt or compression type fitting or an Engineer approved method. On metal poles, secure the #6 AWG grounding lead cable to the pole using an Engineer approved method.

Use the following type antenna cable at the following locations:

| No. | Corridor | Location | Antenna Cable | Ethernet Radio Configuration | Antenna Type |
|-----|----------|-----------|---------------|------------------------------|--------------|
| 1 | I-26 | Pond Road | LMR-400 | PTP | Yagi* |
| 2 | I-40 | I-240 | LMR-600 | Repeater | Omni* |
| 3 | I-26 | MM 28.8 | LMR-400 | Repeater | Two Yagi* |
| 4 | I-40 | MM 46 | LMR-400 | PTP | Yagi* |
| 5 | I-40 | MM 44.5 | LMR-400 | PTP | Yagi* |

* Based on the results of the radio path site survey as specified in subsection entitled "Site Survey" under "Construction Methods" below, the location, antenna type and radio configuration may be subject to change. In these instances, the Contractor shall install the appropriate antenna type and configure each radio to achieve the maximum signal transfer.

H. Cabinet and Electrical Power Wiring

Provide surge protection in controller cabinets to comply with the radio manufacturer's recommendations for these protectors.

Furnish outdoor rated CAT-6 Ethernet cable to be installed between the 2.4 GHz Ethernet radio transceivers and Ethernet power injector. Provide all necessary Ethernet patch cables and ensure cables are of appropriate length.

Connect the Ethernet surge protection devices between the Ethernet power injector and the 2.4 GHz Ethernet radio. This installation technique is designed to restrict earth current transients induced within the ground or directly from the power source from entering the Ethernet radio.

Ensure that installing the Ethernet radio transceivers with a fully functional traffic signal controller does not require any field device modifications with regards to hardware or software.

Fasten all wiring and harness supports to the cabinet with screws or other removable mechanical means. Do not use adhesives.

Do not locate terminals on the underside of the shelf or at other places where they are not readily visible and accessible, or where they may be a hazard to personnel. Provide a clear plastic guard for exposed 120 VAC terminals on the power panel.

◆ **Revision No. 1, April 10, 2017 - This document supersedes version originally issued and sealed by J. Todd Brooks, NCPE No. 017586 on 12/28/2016**

Permanently label all cables entering the cabinet. Ensure the power supply for the radio system is **NOT** connected to the GFCI receptacle circuit located in the cabinet. Place a copy of all manufacturer equipment specifications and instruction and maintenance manuals in the equipment cabinet.

I. Routing of Cable for Antennas Mounted on Metal Poles

Do not create any new holes in the existing metal poles and transformer bases nor enlarge any existing holes. In all cases, use the same holes through which signal cables and communications cable currently pass to feed the antenna cables into and out of the poles. Do not feed antenna cables through holes or conduits that contain electrical conductors.

Where the Plans call for routing the antenna cable from the controller cabinet to the antenna through the interior of the metal pole, install the antenna cable in a continuous non-metallic flexible conduit from the antenna cable's entry point to its exit point to shield the cable from unfused electrical conductors present inside the pole. Provide a non-intrusive means for securing the upper end of the flex conduit to the interior of the pole so that it does not drop down to the pole base.

On wood poles, attach a 1" rigid galvanized riser with heat shrink tubing (unpainted) using conduit straps. Route the antenna cable from the signal cabinet mounted on the wood pole to the antenna mounted on the wood pole through this riser.

Refer to the special details in the Plans for additional cable routing and antenna mounting details.

J. Wireless Ethernet Testing

Description: The wireless Ethernet links must be tested prior to purchasing the Ethernet radios and once the wireless links are installed. The wireless testing prior to purchasing of the radios will validate the viability of each wireless link and will adjust any radio mounting locations. Following installation of the wireless network sections, acceptance testing must be conducted to demonstrate that wireless links are providing maximum throughput and that wireless network sections passing through repeater sites are providing acceptable throughput.

Tree Foliage Constraint: All wireless testing must be completed when 90% of peak tree foliage has developed or remains on the trees along a link or corridor being tested. The Engineer has final approval of the wireless testing timeframe based on this requirement.

Wireless Acceptance Testing: Test the installed and configured individual wireless links and wireless network connections. A wireless link is defined as being between two Ethernet radios. A wireless network connection may be between two Ethernet bridge radios at intersections or may pass through multiple repeaters to provide a wireless connection between Ethernet switches at adjacent intersections.

Test Procedure: Develop a wireless link and wireless network connection testing procedure that follows the RFC 2544 protocol. The procedure must be approved by the Engineer. The test procedure must determine the throughput of each individual wireless link and for each wireless network connection.

Acceptance: A wireless link and network connection will be accepted as complete when testing results demonstrate and document that each installed wireless link meets or exceeds the initial link test results, and the throughput meets or exceeds 22 Mbps 90% of the time. The

◆ **Revision No. 1, April 10, 2017 - This document supersedes version originally issued and sealed by J. Todd Brooks, NCPE No. 017586 on 12/28/2016**

U-4715B**ITS-230****Buncombe County**

wireless network connections must meet or exceed the initial test results for the worst case wireless link that composes the wireless network connection. Provide all equipment and personnel needed to safely conduct the test and arrange for the Engineer's representative to witness the tests.

K. Training

A factory certified representative shall provide two (2) days of local training after radios have been installed and are operational.

33.4. MEASUREMENT AND PAYMENT

2.4 GHz Ethernet radio will be measured and paid as the actual number of 2.4 GHz Ethernet radios furnished, installed and accepted according to following conditions: 80% of the payment will be made upon acceptance of the installed radio system and the remaining 20% of the payment will be made following final acceptance (including completion of the 60-day Observation Period). This item includes the appropriate antenna(e), Ethernet cable, PoE adapter, Ethernet power injector, grounding system with weatherproofing, surge protection, installation materials, configuration software, labeling, any integration between the bridge system and the fiber-optic network (if necessary) and warranties.

The Contractor shall be responsible for providing a complete, functional system including all necessary cables and connectors in accordance to the specifications and as specified in the Plans. All miscellaneous patch and interconnect cables shall meet the proposed equipment specification requirements and shall meet EIA/TIA telecommunications standards.

No measurement will be made of power supplies, power cords, adapters, antenna mounting hardware, stainless steel banding hardware and clamps, connectors, cables, non-metallic flex conduit, grommets, cable ties, surge protection devices, cable splitters, non-intrusive mounting systems for cable splitters, low-loss coaxial cable, and installation materials necessary to complete this work, including the radio path site survey test and warranties, as these will be considered incidental to furnishing and installing 2.4 GHz Ethernet radios.

Riser assemblies will be measured and paid for separately in accordance with the "Riser Assemblies" section of these Project Special Provisions.

Payment will be made under:

| Pay Item | Pay Unit |
|------------------------|-----------------|
| 2.4 GHz Ethernet Radio | Each |

34. ETHERNET CABLE

34.1. DESCRIPTION

Furnish and install copper Ethernet cable, as shown in the Plans, for interconnecting various hardware in an Ethernet network located between the traffic signal cabinets, CCTV cabinets, the TMC, and the City of Asheville Transportation Department in City Hall. Furnish and install Ethernet patch panels for terminating Ethernet cable in the TMC.

34.2. MATERIALS

A. Ethernet Cable

Provide shielded Category 6 Ethernet outdoor-rated cable that complies with ANSI/TIA-568-C.2 standards for four-pair shielded twisted copper for Ethernet communications. The cable shall meet all of the mechanical requirements of ANSI/ICEA S-80-576 applicable to four-pair inside wiring cable for plenum or general cabling.

Furnish Ethernet cable meeting the following minimum performance requirements:

- Specified frequency range: 1-250 MHz
- Impedance: 100 ohms
- Return Loss: 201. dB
- Attenuation: 22 dB
- Near End Crosstalk (NEXT): 35.3 dB
- Power Sum NEXT: 32.3 dB
- ELFNEXT: 23.8 dB
- Delay Skew: 45 ns
- Nominal Impedance: 14 pF/ft

Furnish Ethernet cable meeting the following physical requirements:

- Jacket: PVC, UV resistant
- Jacket Color: Black
- Insulation: Polyolefin
- Core: Gel-filled or flooded core
- Binder: Clear mylar with 100% coverage
- Shield: Aluminum/mylar with 100% coverage
- Drain Wire: N/A
- Conductors: Solid annealed copper
- Conductor Color Codes: White-Blue/Blue, White-Orange/Orange, White-Green/Green, White-Brown/Brown
- Conductor size: 24 AWG

For Ethernet cable installed in outdoors on aerial messenger cable and in underground conduits, provide the cable rated for such conditions (i.e., UV-resistant, wet conditions, etc.).

B. Cable Management

Wire and cable must provide integrated features to enhance cable management. Integrated cable management features shall include:

- Ascending Descending Sequential Foot Markings: The cable shall provide ascending/descending sequential foot markings printed on the cable jacket. The foot markings shall be used to determine the exact length of cable runs and/or determine the amount of cable remaining in/on a box or reel.
- Alphanumeric Cable Labeling Coding System: The cable shall provide alphanumeric cable labeling coding system printed on the cable jacket. The printed coding system shall include the following alphanumeric characters to allow cable identification without the need for separate adhesive-style labels: A, B, C, D, E, 0, 1, 2, 3, 4, 5, 6, 7, 8, 9. The coding system shall allow easy cable labeling using a standard waterproof marker for: identification of devices, device addresses, zone/circuit cable numbers, etc.
- Cable Colors: The cable shall be available with different color stripes and solid jacket colors. The cable coloring may be used with the alphanumeric cable labeling system to further enhance cable identification to maximize field productivity during system installation and/or maintenance and service.
- Integral Rip Cords: Cables 18 AWG and larger shall include an integral rip cord to provide for easier field stripping of the cable jacket.

Utilize pre-lubricated cable treated with a lubricant to increase cable pulling productivity and efficiency and to decrease the risk of cable damage due to excessive pulling strengths. A non-staining lubricant shall be applied to coat the full length of the cable during the manufacturing process. The lubricant shall produce a low coefficient of friction on the cable jacket material that reduces pulling friction by up to 70%. The lubricant shall continue to reduce friction after it has dried; remaining as a slippery film that retains lubricity for months after use. The cable lubricant shall comply with the physical and performance requirements of Telcordia Standard, TR-NWT-002811, and Generic Requirements for Cable Placing Lubricants. The lubricant shall not contain solvents nor have a flash point.

Furnish color coded cables to denote the type of connection between devices. The colors shall be:

- TMC and City of Asheville Transportation Department:
 - ITS Servers and firewall - Blue
 - Video Servers and Video Processor Units – Yellow
 - Workstations and UPS – Gray
 - Video encoders and decoders – Green
 - Test Cabinets - Orange
- Exterior Cable - Black
- Field Device Cabinets:
 - Traffic Signal Controllers – Blue
 - Conflict Monitors - Red
 - CCTV Cameras – Black
 - Video Encoders – Green
 - Laptop - Gray

◆ **Revision No. 1, April 10, 2017 - This document supersedes version originally issued and sealed by J. Todd Brooks, NCPE No. 017586 on 12/28/2016**

U-4715B

ITS-233

Buncombe County

C. Connectors

Provide RJ-45 connectors with gold wire conductors terminated according EIA/TIA-568-A/568-B standards. Provide connectors with eight contacts. Furnish connectors appropriately rated for the cable being installed. Provide cables with factory-installed connectors for interior cables.

D. Ethernet Patch Cords

Furnish Fast Ethernet patch cords meeting the following physical requirements:

- Minimum of five (5)-foot length,
- Category 6,
- Factory pre-installed RJ-45 connectors on both ends,
- Molded anti-snag hoods over connectors, and
- Gold plated connectors.

Furnish Ethernet patch cords meeting the following minimum performance requirements:

- TIA/EIA-568-A-5, Additional Transmission Performance Specifications for 4-pair 100 Ω Category 6 Cabling.
- Frequency Range: 1-100 MHz.
- Near-End Crosstalk (NEXT): 30.1 dB.
- Power-sum NEXT: 27.1 dB.
- Attenuation to Crosstalk Ratio (ACR): 6.1 dB.
- Power-sum ACR: 3.1 dB.
- Return Loss: 10 dB. and
- Propagation Delay: 548 nsec.

E. Environmental Requirements**1. Outdoor Cable**

Provide 4-pair twisted copper Ethernet cable and connectors rated for an ambient operating temperature range of -30° to 165° F. The cable shall be shielded, outdoor-rated and have a UV resistant jacket. The void between the insulated copper pairs and the polyethylene outer jacket shall be injected with a water resistant flooding compound.

2. Indoor Cable

Provide 4-pair twisted copper Ethernet cable and connectors rated for an ambient operating temperature range of -30° to 165° F. Furnish factory pre-terminated/pre-connectorized Ethernet cables whenever possible. Provide factory pre-connectorized Ethernet cables for all cables that are less than or equal to 12 feet in length.

34.3. CONSTRUCTION METHODS**A. General**

Install color-coded Category 6 Ethernet cable for traffic signal controller and CCTV cabinets, on traffic signal and utility poles, and in conduits or on messenger cable to bring the cable between traffic signal controller and CCTV cabinets. Use color-coded cable as described in these Project Special Provisions above.

◆ **Revision No. 1, April 10, 2017 - This document supersedes version originally issued and sealed by J. Todd Brooks, NCPE No. 017586 on 12/28/2016**

U-4715B**ITS-234****Buncombe County**

Furnish all tools, equipment, materials, supplies, and hardware necessary to install a fully operational Ethernet cable system as depicted in the Plans. Install the Ethernet cable according to the latest version of the manufacturer's cable installation procedures and the industry-accepted installation standards, codes, and practices, or as directed by the Engineer.

Take all precautions necessary to ensure the Ethernet cable is not damaged during storage and installation. Do not step on the cable nor run over the cable with vehicles or equipment. Do not pull the cable over or around obstructions or along the ground.

Immediately cease work and notify the Engineer and the affected owner should damage to existing cables or equipment occur. Make the required repairs at no additional cost to the Department.

Provide the Engineer with three copies of the Ethernet cable manufacturer's recommended and maximum pulling tensions for each Ethernet cable size before the installation of Ethernet cable.

Install Ethernet cable in continuous lengths with no splices outside cabinets.

Cut cables to length to minimize coils of spare cable. Cut outer jacket and trim conductors per manufacturer's recommendations. Ensure all conductors extend to the end of the channel and make solid electrical contact with the gold connectors. Crimp the RJ-45 connector body to lock conductors in channels.

B. Aerial Installation

Use pole attachment hardware and roller guides with safety clips to install the aerial Ethernet cable.

Maintain tension during the pulling process for aerial run Ethernet cable by using a mechanical clutch (dynamometer) device with breakaway swivel approved by the Engineer. Do not exceed 80 percent of the manufacturer's maximum allowable pulling tension. Do not allow the Ethernet cable to contact the ground or other obstructions between the poles during installation. Do not use a motorized vehicle to generate cable-pulling forces.

C. Messenger Cable Installation

Double lash the Ethernet cable to the messenger cable where the messenger cable is used solely to support the communications cable.

Wrap the communications cable to the messenger cable using aluminum ribbon wraps where the messenger cable supports other cables (i.e., traffic signal cable, lead-in cable, etc.).

D. Underground Installation

Install underground Ethernet cable as shown in the Plans using cable-pulling lubricants approved by the Ethernet cable manufacturer and the Engineer. Obtain the Engineer's approval of the cable lubricant and method of pulling before the installation of underground Ethernet cable.

Do not exceed 80 percent of the manufacturer's maximum pulling tension when installing underground Ethernet cable.

◆ **Revision No. 1, April 10, 2017 - This document supersedes version originally issued and sealed by J. Todd Brooks, NCPE No. 017586 on 12/28/2016**

U-4715B**ITS-235****Buncombe County**

Use a clutch device (dynamometer) with breakaway swivel so as not to exceed the allowable pulling tension if the cable is pulled by mechanical means. Do not use a motorized vehicle to generate cable-pulling forces.

Keep tension on the cable reel and the pulling line at the start of each pull. Do not release the tension in the cable if the pulling operation is halted. Restart the pulling operation by gradually increasing the tension until the cable is in motion.

Set cable reels up on the same side of the junction box as the conduit section in which the cable is to be installed. Place the reel level and align the reel with the conduit section such that the cable will pass from the top of the reel in a smooth bend into the conduit without twisting. Do not pull the cable from the bottom of the reel. Manually feed the cable by rotating the reel. Do not pull the cable through intermediate junction boxes, pull boxes, handholes, or openings in conduit unless otherwise approved by the Engineer.

Crimp the RJ-45 connector body to lock conductors in channels. Test each connector from end to end.

E. Above-Ceiling Installation

Install Ethernet cable in the TMC and in City hall in cable trays as shown in the Plans using the above described pulling methods. The installation of the cable tray in the TMC is included in this project. The cable tray within City of Asheville Transportation Department is existing above the acoustical ceiling.

F. Ethernet Patch Cords

Install Ethernet patch cords between Ethernet patch panels and devices and network interface box and devices.

34.4. MEASUREMENT AND PAYMENT

Ethernet cable will be measured and paid as the actual linear feet of Ethernet cable furnished, installed, and accepted regardless of the color of the outer jacket. Measurement will be made by calculating the difference in length markings located on outer jacket from start of run to end of run for each run. No measurement will be made of connectors as such work is considered incidental to installing the Ethernet cable.

No measurement will be made for Ethernet patch cables that connect adjacent devices/equipment (e.g., between an Ethernet edge switch and a controller housed in the same cabinet) as they will be considered incidental to furnishing and installing the equipment that they connect.

Payment will be made under:

| Pay Item | Pay Unit |
|-----------------|-----------------|
| Ethernet Cable | Linear Foot |

◆ **Revision No. 1, April 10, 2017 - This document supersedes version originally issued and sealed by J. Todd Brooks, NCPE No. 017586 on 12/28/2016**

35. CCTV FIELD EQUIPMENT

35.1. DESCRIPTION

Furnish and install CCTV field equipment, cabinets and local camera control software described in this Section. Remove and deliver existing CCTV field equipment and cabinets that will not be used per Section 1 of these Project Special Provisions and as shown in the Plans.

Furnish and install new electrical service for CCTV where shown in the Plans.

Provide a system to protect field devices and electronic equipment from lightning and surge protection using UL[®] listed surge protection devices.

35.2. MATERIALS

A. General

Provide new CCTV camera assemblies and cabinets and all wiring as shown in the Plans. Each CCTV camera assembly shall consist of the following:

- NEMA environmental dome enclosure,
- CCTV color digital signal processing camera unit integrated encoder, zoom lens, filter, control circuit, and accessories,
- Motorized pan, tilt, and zoom,
- Power supplies,
- Pole-mount camera attachment hardware,
- Built-in video encoder cable of H.64/MPEG-4 compression for video-over IP transmission,
- All necessary cable, connectors and incidental hardware to make a complete and operable system,
- NEMA Type 4, IP 66 enclosure constructed of aluminum with a clear acrylic dome or approved equal camera unit housing,
- Composite cable for power supply and Ethernet communications, and
- Surge protection devices.

Provide Type 336A cabinets for CCTV cabinets as shown in the Plans.

Furnish all tools, equipment, materials, supplies and hardware necessary to install a fully operational CCTV camera system as depicted in the Plans and described in these Project Special Provisions.

Provide all hardware and mounting brackets required to mount CCTV camera assemblies and CCTV cabinets to metal and wood poles as required by the Plans. Attach camera mounting brackets and CCTV cabinets to poles using Engineer-approved stainless steel banding hardware and clamps. Submit catalog cuts/manufacturer's literature for banding hardware and clamps to the Engineer for approval.

B. Standards

- ANSI,
- ASTM,
- CE, Class B,
- EIA Standards 170, 232, 422, 250C and 485,
- FCC Rules Part 15, Sub-part J,
- FCC Class A,
- FCC, Class B,
- IEEE,
- ICEA,
- IMSA,
- ISO 9001,
- NEC,
- NEMA 4X, IP 66,
- NEMA Type 1,
- NTSC, and
- UL Listed.

Provide UL listed surge protection devices according to the UL 1449, 2nd edition standard that comply with the NEMA requirements as detailed in the NEMA TS 1 (1992) standard.

Provide a means to ground all equipment as called for in the Standard Specifications, these Project Special Provisions, and the Plans.

C. Camera Assembly

Furnish new CCTV camera assemblies at locations shown on the Plans. Each assembly consists of one dome CCTV camera that contains, in a single enclosed unit, the following functionality and accessories:

1. Cameras

Provide new 1/3-inch charged-coupled device (CCD) color day/night cameras. The sensors shall use Complementary Metal-Oxide-Semiconductor (CMOS) technology. The camera must meet the following minimum requirements:

- | | |
|----------------------------|--|
| • Video signal format: | NTSC compatible resolution, user selectable up to a maximum of 1920 x 1080 (1080p) |
| • White balance: | Automatic through the lens with manual override, |
| • Electronic-shutter: | DIP-switch selectable NTSC electronic shutter with speed range from 1/2 of a second (off) to 1/30,000 of a second (NTSC), |
| • Overexposure protection: | Built-in circuitry or a protection device to prevent any damage to the camera when pointed at strong light sources, including the sun, |
| • Gain control: | Automatic and manual, |
| • Sensitivity: | 0.6 lux at 90% scene reflectance, with f/1.6 and 28 dB gain, |

◆ **Revision No. 1, April 10, 2017 - This document supersedes version originally issued and sealed by J. Todd Brooks, NCPE No. 017586 on 12/28/2016**

U-4715B**ITS-238****Buncombe County**

- Input/Output Connection: Single 10BASE-T/100BASE-T compatible outdoor-rated Category 6 cable for video and control, and IP66-rated RJ45 connector
- Security: Min. 20 users in unicast mode, unlimited in multicast
- Open Application Programming Interface (API): ONVIF Profile S
- Primary supply voltage: 120 VAC,
- Camera voltage: 24 VAC or 24 VDC, and
- Camera power: 73 VA with heater and blower at 24 VAC.

2. Lens

Provide each camera with a motorized zoom lens with automatic iris control with manual override and neutral density spot filter. Provide lenses that meet the following optical specifications:

- Automatic focus: Automatic with manual override, Electronic Image Stabilizations (EIS)
- Horizontal angle of view: 59 degrees at 4.3 mm wide zoom and 2.1 degrees at 129 mm telephoto zoom,
- Focal length: 4.3 mm to 129 mm, 30X optical zoom, 12X electronic zoom,
- Zoom Speed: 2.9, 4.2 and 5.8 seconds,
- Lens aperture: Minimum of f/1.6 to f/4.7,
- Maximum Sensitivity at 35 IRE: .025 lux at ½ second color, .1 lux at 1/60 second black and white, .004 lux at ½ second black and white,
- Preset positioning: Minimum of 128 presets.

The lens must be capable of both automatic and remote manual control iris and focus override operation. The lens must be equipped for remote control of zoom and focus, including automatic movement to any of the preset zoom and focus positions. Provide mechanical or electrical means to protect the motors from overrunning in extreme positions. The operating voltages of the lens must be compatible with the outputs of the camera control.

3. Camera Housing

Provide new dome style enclosure for assemblies with a high performance integrated dome system or approved equal. Provide the dome housing with a 1½" NPT threaded cable entry. Equip each camera housing with a mounting assembly for attachment to the CCTV camera pole. The enclosures must be equipped with a strip heater. Provide a sunshield fabricated from corrosion resistant aluminum and finished in a neutral color of weather resistant enamel. The viewing area of the enclosure must be tempered glass.

Provide surge protectors for all ungrounded conductors that will enter the CCTV enclosure as described below. House the surge protectors within the CCTV housing in a manner approved by the Engineer.

A dome-type environmental housing shall have a sustained ambient operating temperature of -50 degrees F to 122 degrees F, with 100 percent non-condensing relative humidity as defined within the NEMA TS-2 (1998) standard. The enclosure shall have a NEMA 4X/IP-66 rating.

◆ **Revision No. 1, April 10, 2017 - This document supersedes version originally issued and sealed by J. Todd Brooks, NCPE No. 017586 on 12/28/2016**

U-4715B

ITS-239

Buncombe County

4. Pan and Tilt Unit

Equip each new dome style assembly with a pan and tilt unit. The pan and tilt unit must be integral to dome system. The pan and tilt unit must be rated for outdoor operation, provide dynamic braking for instantaneous stopping, prevent drift, and have minimum backlash. The dome must have an auto flip dome rotation to rotate and reposition camera for viewing objects passing below camera. Provide electronic image stabilization. The pan and tilt units must meet or exceed the following specifications:

- Pan: Continuous 360 degrees,
- Tilt: +2 to -92 degrees minimum,
- Presets: Minimum of 128 presets,
- Preset accuracy: 0.1 degree,
- Preset pan speed: 0.1 degrees/second to 200 degrees/second,
- Preset tilt speed: 0.1 degrees/second to 400 degrees/second,
- Privacy zones: Minimum of eight user configurable shapes,
- Input voltage: 24 VDC or 24 VAC, and
- Motors: Two-phase induction type, continuous duty, instantaneous reversing.

5. Power Supplies

Furnish a camera power supply recommended by the manufacturer for use with the camera. Furnish a power supply that is rated for outdoor use, is compatible with the AC electric service source (e.g., traffic signal cabinet), and provides power within the input range of the camera. Furnish camera power cable from the camera manufacturer as follows:

- Three wire consisting of power conductors and bond wire,
- 8 AWG power conductors,
- 6 AWG bond wire, and
- THWN stranded.

D. Camera Mounting Bracket

Provide a pole attachment assembly for the CCTV camera unit to mount on wood poles, metal poles, and metal poles with mast arms. The attachment assembly shall use stainless steel banding around the pole approved by the Engineer. Provide black stainless steel banding for attaching the assembly to existing metal poles that have a black finish/coating.

Submit shop drawings of the attachment assembly for review and approval by the Engineer prior to delivery.

Provide the CCTV attachment assembly that allows for the removal and replacement of the CCTV enclosure as well as providing a weatherproof, weather-tight, seal that does not allow moisture to enter the enclosure.

Provide CCTV camera attachment assembly that is able to withstand wind loading at the maximum wind speed and gust factor called for in the interim revision of the 5th Edition *AASHTO Specifications for Structural Supports for Highway Signs, Luminaries and Traffic Signals* and can support a minimum camera unit dead load of 45 pounds.

◆ **Revision No. 1, April 10, 2017 - This document supersedes version originally issued and sealed by J. Todd Brooks, NCPE No. 017586 on 12/28/2016**

E. Video Encoder

All video encoders must have the following minimum features:

- Network Interface: Ethernet 10/100Base-T (RJ-45 connector)
- Protocols: IPv4, IPv6, HTTP, HTTPS, SSL, QoS, FTP, SMTP, UPnP, SNMP v2c/v3, DNS, NTP, RTSP, RTP, TCP, UDP, IGMP, DHCP
- Security: SSL, SSH, 802.1x, HTTPS encryption with password controlled browser interface
- Video Streams: 2 simultaneous streams, user configurable
- Compression: H.264 (MPEG-4 Part 10/AVC)
- Resolution: Scalable; NTSC-compatible 320x176 to 1920x1080 (HDTV 1080p, 16:9 Aspect Ratio)
- Frame Rate: 1-30 FPS programmable (full motion)
- Bandwidth: 30 kbps – 6 Mbps, configurable depending on resolution
- Edge Storage: SD/SDHC/SDXC slot supporting up to 64GB memory card

Furnish cameras with a built-in digital video Ethernet encoder to allow video-over-IP transmission. The encoder units must be built into the camera housing and require no additional equipment to transmit encoded video over IP networks.

F. Type 336A Camera Cabinet**1. General**

Provide Type 336A CCTV cabinets that provide for and meet the following minimum requirements:

- Ethernet edge switch (paid for separately),
- Termination of the composite cable to the camera,
- Local interface panel with maintenance access points for data and video connections to observe camera images and program/monitor camera status,
- Fiber-optic interconnect center (paid for separately),
- Grounding bus bar,
- 19-inch rack system for mounting of all devices in the cabinet,
- Pull-out shelf for laptop and maintenance use,
- Stationary shelf for shelf-mounting the Ethernet edge switch,
- Fluorescent lighting,
- Ventilation fan,
- Thermostats,
- 120 VAC power supply,
- 120 VAC GFCI-protected duplex outlets for tools,
- 120 VAC surge protected duplex outlets for equipment,
- Surge protection on incoming and outgoing electrical lines (power and data),
- Transformers/power supplies, and
- Power strip along vertical rail.

U-4715B**ITS-241****Buncombe County**

Provide cabinets complete with a prefabricated cabinet shell, and all internal components and equipment, back and side panels, front and back doors, terminal strips, cabling and harnesses, surge protection for power and communication circuits, power distribution blocks or assemblies, shelves, connectors and all mounting hardware necessary for installation of equipment.

Provide the cabinets using unpainted sheet aluminum with a minimum thickness of 0.125 inch.

Provide the rack assembly with a removable, standard 19-inch EIA compliant rack. Equip each cabinet with an aluminum storage compartment mounted in the rack assembly with the following dimensions (± 0.5 inch): 16 inches wide, 14 inches long and 1.75 inches deep. Provide the compartment with ball bearing telescoping drawer guides to allow full extension from the rack assembly. The storage compartment shall open to provide a full-depth storage space for cabinet documentation and other miscellaneous items. The storage compartment shall be of adequate construction to support a weight of 20 pounds without sagging when extended. The top of the storage compartment shall be hinged aluminum. Provide at least one removable metal full-depth shelf with each cabinet.

Provide all cabinets and exterior door seams with continuously welded seams and with smooth exterior welds. Provide all cabinets with two (2) full-size doors (one front, one back). Provide the doors with three hinges, or a full-length stainless steel piano hinge, with stainless steel pins spot-welded at the top. The hinges shall utilize stainless steel hinge pins. Mount the hinges so that they cannot be removed from the door or cabinet without first opening the door. Brace the door and hinges to withstand a 100-pound per vertical foot of door height load applied vertically to the outer edge of the door when standing open. There shall be no permanent deformation or impairment of any part of the door or cabinet body when the load is removed. Provide the cabinet door with a #2 Corbin lock. Provide two keys for each cabinet. Provide the cabinet doors so they can be padlocked. Provide door openings with double flanges on all four sides.

Doorstops shall be included at 90° and 180° positions. Provide both the door and the doorstop mechanism of sufficient strength to withstand a simulated wind load of five pounds per square foot of door area applied to the both inside and outside surfaces without failure, permanent deformation, or compromising of door position and normal operation. Provide the cabinets without auxiliary police doors.

Ensure that cabinet doors include a gasket to provide a dust and weather-resistant seal when closed. Provide the gasket material with closed-cell neoprene and shall maintain its resiliency after exposure to the outdoor environment. The gasket shall show no sign of rolling or sagging, and shall ensure a uniform dust and weather-resistant seal around the entire door facing.

Provide pole-mounted version of the 336A CCTV cabinet.

2. Ventilation

Provide a cooling fan in all cabinets with a minimum capacity of 100 CFM. Provide a thermostat to control the ventilation system.

Provide the cabinets with vent openings in the door to allow convection cooling of electronic components. Locate the vent opening on the lower portion of the cabinet door and cover fully on the inside with a commercially available disposable three layer graded type filter.

◆ **Revision No. 1, April 10, 2017 - This document supersedes version originally issued and sealed by J. Todd Brooks, NCPE No. 017586 on 12/28/2016**

U-4715B**ITS-242****Buncombe County**

Provide cabinets with a serial number unique to the manufacturer. Engrave the entire identification code on a metallic plate that is epoxied to the cabinet on the upper right hand sidewall.

3. Electrical

Provide a power distribution assembly that consists of power filters, transient voltage suppression, equipment grounding, main and branch circuit breakers for equipment, electrical outlets, lighting and ventilation.

Provide AC isolation within the cabinet. Configure all cabinets to accept 120 VAC from the utility company.

Provide UL listed circuit breakers with an interrupt capacity of 5,000 amperes and insulation resistance of 100 MΩ at 500 VDC. Provide power distributions blocks for use as power feed and junction points for two and three wire circuits. The line side of each shall be capable of handling up to 2/0 AWG conductors. Isolate the AC neutral and equipment ground wiring and terminal blocks from the line wiring by an insulation resistance of at least 10 MΩ when measured at the AC neutral.

For components that are furnished by the Contractor that are mounted on cabinet side panels, fasten with hex-head or Phillips-head machine screws. Install the screws into tapped and threaded holes in the panels. The components include, but are not limited to, terminal blocks; bus bars, and DC power supply chassis.

Tag and identify all cabinet wiring installed by the Contractor by the use of insulated pre-printed sleeves. The wire markers shall identify in plain words with sufficient details without abbreviations or codes.

Neatly arrange all wiring in the cabinet, firmly lace or bundle it, and mechanically secure the wiring without the use of adhesive fasteners. Route and secure all wiring and cabling so as to avoid sharp edges and to avoid conflicts with other equipment or cabling. Terminate all wiring on a terminal block, strip, bus bar, device clamp, lug; or connector, do not splice any wiring. Label all wiring, cables, terminal strips, and distribution blocks provided by the Contractor. Provide strain relief for all cabling with connectors, all cabling entering knockouts or ports at the equipment, and where appropriate.

4. Cable Terminations

Terminate the Ethernet field cabling on the Ethernet surge protection device for the Ethernet communications. Terminate Ethernet data cables in RJ-45 connector plug receptacles. Terminate power conductors on the surge protection devices. Clearly and permanently factory label all input and output cable sides.

G. Composite Cable

Provide a composite cable for carrying the CCTV power and Ethernet communications between the camera and CCTV cabinet. The composite cable is required to provide sufficient amperage to operate the camera heater and blower. The composite cable shall consist of:

- Outer jacket composed of UV resistant PVC,
- Ethernet cable (refer to "Ethernet Cable" section of these Project Special Provisions)

◆ **Revision No. 1, April 10, 2017 - This document supersedes version originally issued and sealed by J. Todd Brooks, NCPE No. 017586 on 12/28/2016**

U-4715B**ITS-243****Buncombe County**

- Power Cable,
 - 14 AWG, two conductors
 - 12 AWG, green bond wire
 - Three wire, and
 - THWN stranded.

For CCTV-29 at the intersection of McDowell Street at Lodge Street (Sig. Inv. No. 13-0389), use 12 AWG power conductors with a 10 AWG bond wire due to the distance around the intersection to the camera from the traffic signal cabinet.

H. Surge Suppression

Provide surge protection both ahead of and behind the ITS device electronics for the cameras. All surge protection devices shall have an ambient operating temperature of -40 degrees F to 165 degrees F with 95 percent non-condensing relative humidity. All surge protection devices shall comply with the following standards:

- UL 1449 version 3 for electrical power,
- UL 497B for paired data communications, and

For those CCTV cabinets with Ethernet communications over twisted-pair copper cable, provide surge protection devices meeting UL 1449A.

Provide surge protection for all four pairs of the Ethernet cable. Data voltage shall be 48 VDC. Surge protector will function with a Maximum Continuous Operating Voltage (MCOV) of 64VDC, and will clamp (on 1000VDC, 1mA, 10/1000 μ s waveform) at 72VDC +/- 5V. The maximum continuous current on data lines under normal conditions will be 1.5 A. The peak surge current that can be passed on any pair of data lines can be no more than 30A. Response time on data lines shall be no more than 1 pico-seconds.

1. Line Side CCTV Power

Each cabinet must be provided with a hybrid-type, power line surge protection device mounted inside the power distribution assembly. The protector must be installed between the applied line voltage and earth ground. The surge protector must be capable of reducing the effect of lightning transient voltages applied to the AC line. The protector must be mounted inside the power distribution assembly housing facing the rear of the cabinet. The protector must include the following features and functions:

- Maximum AC line voltage: 140 VAC,
- Twenty pulses of peak current, each of which must rise in 8 microseconds and fall in 20 microseconds to ½ the peak: 20,000 Amperes,
- The protector must be provided with the following terminals:
 - Main line (AC line first stage terminal),
 - Main neutral (AC neutral input terminal),
 - Equipment line out (AC line second state output terminal, 19 amps),
 - Equipment neutral out (neutral terminal to protected equipment),
 - Ground (earth connection),
- The main AC line in and the equipment line out terminals must be separated by a 200 Microhenry (minimum) inductor rated to handle the 10 Amp AC service,
- The first stage clamp must be between main line and ground terminals,

◆ **Revision No. 1, April 10, 2017 - This document supersedes version originally issued and sealed by J. Todd Brooks, NCPE No. 017586 on 12/28/2016**

U-4715B**ITS-244****Buncombe County**

- The second stage clamp must be between equipment line out and equipment neutral,
- The protector for the first and second stage clamp must have an MOV or similar solid-state device rated at 20 KA and must be of a completely solid-state design (i.e., no gas discharge tubes allowed),
- The main neutral and equipment neutral out must be connected together internally and must have an MOV similar solid-state device or gas discharge tube rated at 20 KA between main neutral and ground terminals,
- Peak clamp voltage: 350 volts at 20 KA (voltage measured between equipment line out and equipment neutral out terminals. Current applied between main line and ground terminals with ground and main neutral terminals externally tied together),
- Voltage must never exceed 350 volts, and
- The protector must be epoxy-encapsulated in a flame-retardant material.
- Continuous service current: 10 Amps at 120 VAC RMS.
- The equipment line out must provide power to cabinet CCTV and communications equipment and to the 24V power supply.

2. Load Side CCTV Power

Load side protection is designed to restrict surge current transients from entering the power source from the CCTV device and/or site. The surge protection for the CCTV power source shall have an operating voltage of 28 volts single phase and a maximum continuous operating voltage of 34 volts single phase.

The device's surge protection shall be rated at a minimum of 10,000 amps and have maximum clamping voltage ratings of 34 VAC. The surge protection shall also be UL listed for a minimum suppressed voltage of 330 volts per line to the neutral/ground. The maximum leakage current is 5 microhenries at 28 volts. The maximum load current is 10 amps. The suppression device shall be of the metal oxide varistor (MOV) type.

3. Load Side CCTV Data

Provide specialized surge protection devices at the supply and load sides of all low voltage connections to the CCTV device and its operating subsystems. Provide specialized surge protection devices at the supply and load sides of all low voltage Ethernet data connections between a CCTV and traffic signal cabinet.

The surge protection shall have an operating voltage to match the characteristics of the CCTV, such as 28 volts of alternating current and less than 5 VDC for data functions. These specialized surge protection units shall be UL listed according to the UL 497B (paired-data cable) standards. The minimum surge current rating for the surge protection shall be 2,000 amps for data and telecommunications, 2,000 amps for twisted pair video.

I. Grounding

Provide a cabinet grounding system for the Type 336A cabinets as shown in the Plans. Incorporate a means to bond (i.e., connect) all metal components of the camera and cabinets to the grounding system with a grounding cable that uses a mechanical connection on the equipment side and an exothermic welded connection at the down cable.

◆ **Revision No. 1, April 10, 2017 - This document supersedes version originally issued and sealed by J. Todd Brooks, NCPE No. 017586 on 12/28/2016**

U-4715B**ITS-245****Buncombe County**

Provide a minimum of four grounding electrodes with a minimum length of 10 feet each and listed according to UL requirements as detailed in the *UL 467J* standard. Provide copper clad or solid copper electrodes.

J. Software

Provide Vendor-supplied GUI-based software to setup, configure and operate the cameras in the field. This software shall include features to set communications addresses and protocols, define camera ID lens control, digital signal processing (DSP) settings, azimuth configuration, presets, tours, and privacy zones. The software shall allow the user to control all functions of the camera locally from the CCTV cabinet at the base of the pole with a serial or USB cable.

35.3. CONSTRUCTION METHODS**A. Electrical and Mechanical Requirements**

Ground all equipment as called for in the *Standard Specifications*, these Project Special Provisions, and the Plans.

The air terminal ground wire must not pass through any equipment cabinet or enclosure.

Electrically bond each camera and pan/tilt/zoom mechanism and its housing to the CCTV camera attachment assembly using a number 6 AWG braided copper conductor.

B. CCTV Cabinet

Mount the CCTV cabinet on the pole supporting the CCTV camera it controls using approved hardware and attachment brackets. Mount the cabinet 4 feet from the ground to the center of the cabinet. Avoid mounting cabinets where they will overhang and encroach upon an adjacent sidewalk or pedestrian path. Where a minor overhang of the sidewalk or pedestrian path cannot be reasonably avoided, ensure that a minimum of four feet of clear sidewalk width will remain once the cabinet is installed. Do not mount cabinets above pedestrian pushbuttons or where they will hinder access to pedestrian pushbuttons. Have the Engineer approve the proposed mounting position prior to attaching the CCTV cabinet to the pole.

Ground all CCTV cabinets in accordance with the requirements of these Project Special Provisions. Keep the ground wire from the cabinet ground bus bar to the ground rod assembly or array as short as possible. Ensure the ground wire is not in contact with any other part of the cabinet.

Tag and identify all cabinet wiring installed by the Contractor by the use of insulated pre-printed sleeves. The wire markers shall identify in plain words with sufficient details without abbreviations or codes.

Neatly arrange all wiring, firmly lace or bundle it, and mechanically secure the wiring without the use of adhesive fasteners. Route and secure all wiring and cabling to avoid sharp edges and to avoid conflicts with other equipment or cabling. Terminate all wiring on a terminal block, strip, bus bar, device clamp, lug, or connector, do not splice any wiring. Label all wiring, cables, terminal strips, and distribution blocks installed by the Contractor. Provide strain relief for all cabling with connectors, all cabling entering knockouts or ports at the equipment, and where appropriate.

Fasten all components installed by the Contractor to be mounted on cabinet side panels with hex-head or Phillips-head machine screws. Install the screws into tapped and threaded holes in

◆ **Revision No. 1, April 10, 2017 - This document supersedes version originally issued and sealed by J. Todd Brooks, NCPE No. 017586 on 12/28/2016**

U-4715B**ITS-246****Buncombe County**

the panels. The components include, but are not limited to, terminal blocks; bus bars, and DC power supply chassis.

Stencil the CCTV camera number on both the front and rear doors of the Type 336A CCTV cabinet or the adjacent traffic signal controller cabinet where there is no separate CCTV cabinet. Place the CCTV camera number below the signal inventory number on traffic signal controller cabinets. Use 3-inch black characters.

Install new Type 336A CCTV camera cabinets as shown in the Plans. Connect the cabinet to the CCTV camera assembly with an Ethernet cable and low voltage power conductors. Mount the fiber-optic interconnect center in accordance with the "Fiber-Optic Communications Cable" section of these Project Special Provisions. Install the Ethernet edge switch inside the cabinet in accordance with the "Communications Hardware" section of these Project Special Provisions. Connect the appropriate connectors on the interconnect center with those on the Ethernet edge switch using SMFO jumpers.

C. Power Service

For Type 336A CCTV cabinets, provide 120 VAC power from an existing, modified or proposed electrical service as shown on the Plans. For locations where a power service is shared with by adjacent CCTV and signal cabinets, modify the existing electrical service or provide a new electrical service to provide separate breakers for the respective cabinets in the service disconnect. For all other Type 336A CCTV cabinets, install new power service under separate pay item as shown in the Plans. Comply with the "Electrical Service" section of these Project Special Provisions and the details shown in the Plans.

At locations identified in the Plans where there no separate CCTV cabinet is being installed, obtain 28VAC power from the adjacent traffic signal controller cabinet.

D. Grounding

Ground the CCTV pole and subsystems in accordance with the special details in the Plans.

E. Composite Cable

Install the composite cable between each camera and its respective cabinet (traffic signal controller cabinet or CCTV cabinet). Connect the power conductors and the Ethernet cable to their respective surge protection devices in the cabinet. Ensure each camera is configured to operate its heater and blower.

F. Surge Protection

1. Device Line Side Power

Connect the surge protection devices on the CCTV power source on the line side. This device shall provide protection between line-to-neutral, line-to-ground, line-to-line and neutral-to-ground.

2. Device Load Side Power

Connect the surge protection devices in the power line side ahead of all CCTV electronic equipment. This installation technique is designed to restrict earth current transients induced within the ground or directly from the power source from entering the ITS device through the incoming 120/240-volt power circuit. This device shall provide protection between line-to-

◆ **Revision No. 1, April 10, 2017 - This document supersedes version originally issued and sealed by J. Todd Brooks, NCPE No. 017586 on 12/28/2016**

U-4715B**ITS-247****Buncombe County**

neutral, line-to-ground, line-to-line and neutral to ground. Install surge protection devices in the CCTV cabinets in accordance with the special details in the Plans.

3. Device Data

Connect the specialized surge protection devices at the supply and line sides of all Ethernet communications to the CCTV device and its operating subsystems. Install surge protection devices in the CCTV in accordance with the special details in the Plans.

G. CCTV Camera Attachments

Install the camera attachment assembly to the mounting bracket in a manner that allows for the removal and replacement of the CCTV enclosure as well as providing a weatherproof, weather-tight seal that does not allow moisture to enter the enclosure.

Install CCTV camera attachment assembly that is able to withstand wind loading at the maximum wind speed and gust factor called for in the *AASHTO Standard Specifications for Structural Supports for Highway Signs, Luminaires and Traffic Signals*, 5th Edition, and can support a minimum camera unit dead load of 45 pounds.

Mount CCTV camera units at a height sufficient to adequately see traffic in all direction and as approved by the Engineer. Mount cameras on poles at the attachment heights shown in the Plans.

Mount CCTV camera on the side of pole that is nearest to the intended field of view, to avoid occlusion of the view by the pole or utility lines. Obtain approval of camera orientation from the Engineer. Comply with the "CCTV Wood Poles" section of these Project Special Provisions.

Have the Engineer approve the pole location prior to installing the camera on an existing pole and prior to setting a new pole. At locations shown in the Plans, assemble the camera attachment hardware for the CCTV camera unit and attach to the pole using stainless steel banding approved by the Engineer. Submit shop drawings for review and approval by the Engineer prior to installation.

H. Cellular Communications

Install Department-furnished cellular telephone modems and associated antennas at proposed location of CCTV-07 on I-26 at Ferry Road (Milemarker 34) to provide the communications link to the TMC in lieu of a fiber-optic communications link. Notify the Division Traffic Engineer at least 8 weeks in advance of need for cellular telephone modems and antennas.

I. Software

If Vendor software is provided to program and operate the cameras, install the Vendor-supplied GUI-based software to setup, configure and operate the cameras on each laptop supplied with the project.

J. GPS Coordinates

Provide real world coordinates for all junction boxes and equipment cabinets installed or utilized under this project. Provide the coordinates in feet units using the North Carolina State Plane coordinate system (1983 North American Datum also known as NAD '83). Furnish coordinates that do not deviate more than 1.7 feet in the horizontal plane and 3.3 feet in the vertical plane. Global positioning system (GPS) equipment able to obtain the coordinate data

◆ **Revision No. 1, April 10, 2017 - This document supersedes version originally issued and sealed by J. Todd Brooks, NCPE No. 017586 on 12/28/2016**

U-4715B

ITS-248

Buncombe County

within these tolerances may be used. Submit cut sheets on the GPS unit proposed to collect the data for approval by the Engineer.

Provide both digital copies and hard copies of all information regarding the location (including to but not limited to manufacturer, model number, City system ID number and NCDOT inventory number) in the Microsoft Excel spreadsheet using the format shown in example below. In addition to Excel format, provide a digital copy of the location information as an ESRI Shapefile (.SHP file format).

| City System ID# | NCDOT Inv # | Name | Location | Latitude | Longitude | Manufacturer | Model # |
|-----------------|-------------|------------------------------------|---|----------|-----------|--------------|-------------------------------------|
| | 05-0134 | Equipment Cabinet | US 70 at Raynor Rd./ Auburn-Knightdale | -78.5500 | 35.6873 | McCain | Type-332 |
| | | Junction Box # 1 (Phase 2 Side) | US 70 at Raynor Rd./ Auburn-Knightdale | -78.5516 | 35.6879 | Quazite | PG1118BA12(Box) PG118HA00(Cover) |
| | | Junction Box # 2 (Phase 2 Side) | US 70 at Raynor Rd./ Auburn-Knightdale | -78.5506 | 35.6876 | Quazite | PG1118BA12(Box) PG118HA00(Cover) |
| | | Junction Box # 3 (Near Cabinet) | US 70 at Raynor Rd./ Auburn-Knightdale | -78.5501 | 35.6873 | Quazite | PG1118BA12(Box) PG118HA00(Cover) |
| | | Junction Box # 4 (Phase 6 Side) | US 70 at Raynor Rd./ Auburn-Knightdale | -78.5486 | 35.6873 | Quazite | PG1118BA12(Box) PG118HA00(Cover) |
| | | Junction Box # 5 (Phase 6 Side) | US 70 at Raynor Rd./ Auburn-Knightdale | -78.5493 | 35.6876 | Quazite | PG1118BA12(Box) PG118HA00(Cover) |
| | | Junction Box # 6 (Phase 4 Side) | US 70 at Raynor Rd./ Auburn-Knightdale | -78.5503 | 35.6879 | Quazite | PG1118BA12(Box) PG118HA00(Cover) |

35.4. MEASUREMENT AND PAYMENT

CCTV camera assembly will be measured and paid as the actual number of CCTV camera assemblies furnished, installed, and accepted according to following conditions: 90% of the payment will be made upon acceptance of the installed CCTV camera assembly and the remaining 10% of the payment will be made following final acceptance (including completion of the 60-day observation period).

No separate measurement will be made for composite power/Ethernet cabling, connectors, CCTV camera attachment assemblies, software, grounding equipment, surge protector devices, other cabling, and conduit, or any other equipment or labor required to install the CCTV assembly and integrate it with the fiber-optic communications equipment as they are considered incidental to furnishing and installing the CCTV camera assembly and the CCTV cabinet.

CCTV cabinet will be measured and paid as the actual number of CCTV cabinets furnished, installed, and accepted, according to following conditions: 90% of the payment will be made upon acceptance of the installed CCTV cabinet and the remaining 10% of the payment will be made following final acceptance (including completion of the 60-day observation period).

No separate measurement and payment will be made for hardware, fasteners, stainless steel bands and brackets required to mount CCTV cabinets to a pole as shown in the Plans as such work will be considered incidental to furnishing and installing the CCTV cabinets.

No measurement will be made of collecting and recording GPS coordinates for junction boxes and CCTV cabinets and compiling this data in the prescribed Microsoft Excel spreadsheet

◆ **Revision No. 1, April 10, 2017 - This document supersedes version originally issued and sealed by J. Todd Brooks, NCPE No. 017586 on 12/28/2016**

U-4715B

ITS-249

Buncombe County

as such work will be considered incidental to furnishing and installing junction boxes and CCTV cabinets.

No measurement and payment will be made for removing existing CCTV equipment (e.g., cameras and their mounting brackets, cabling, cabinets, fiber-optic transceivers, etc.) that will not be retained and used as part of the new CCTV system, nor for delivery of removed CCTV cameras and cabinets and all equipment housed inside to the Division 13 Traffic Services office, and disposal of all other removed CCTV related hardware, as such work will be considered incidental to furnishing and installing CCTV camera assemblies and CCTV cabinets.

No measurement and payment will be made for installing a Department-furnished cellular modem and antenna at a CCTV camera location to provide communications between the CCTV camera and the TMC as such work will be considered incidental to furnishing and installing the CCTV assembly and CCTV cabinet at the same location.

Installation of Ethernet edge switches will be measured and paid for in accordance with the “Communications Hardware” section of these Project Special Provisions.

Payment will be made under:

| Pay Item | Pay Unit |
|----------------------|-----------------|
| CCTV Camera Assembly | Each |
| CCTV Cabinet | Each |

U-4715B

ITS-250

Buncombe County

36. CCTV INTEGRATION AND SOFTWARE MODIFICATION

36.1. DESCRIPTION

Update the Department's existing VideoPro CCTV system software package on the existing video server and update the configuration to add the additional cameras, network video recorders, and video devices provided in this Project. Furnish and install VideoPro on the City Transportation Department workstation.

36.2. CONSTRUCTION METHODS

Protronix's VideoPro is the existing regional video sharing and distribution system that controls the existing CCTV cameras and video monitors at the TMC. The software utilizes a client-server architecture. Modify the Protronix CCTV central software configuration at the TMC to display and map the CCTV devices from the network so that the CCTV video can be displayed on the new monitors and display devices in the TMC and at the City Transportation Department.

Install VideoPro on the City's workstation. Update the existing VideoPro server in the TMC and edit the existing device databases for the new cameras. All additions and edits to the databases must be viewable by all current users of the system.

Update the existing VideoPro server in the TMC for the new monitor wall devices, IP cameras and network video recorders, and PTZ joysticks.

Configure administrative and user VLANs for the VideoPro servers in the TMC Ethernet core switch to enable video sharing.

Integrate the VideoPro software to allow for:

- Remote users to view and control all CCTV devices monitors connected to the TMC through the Ethernet network and the CCTV Control GUI furnished as part of this software such that a user in a facility (TMC or City Staff) can switch, view, and control cameras.
- Department staff to control the network video recorders to record, playback and write to DVD video streams. Playback could be on a workstation monitor or wall monitor.
- Department staff to display signal system software graphics on the wall monitors.

36.3. MEASUREMENT AND PAYMENT

Modify CCTV Software shall be measured and paid as a lump sum. This shall include furnishing, installing, and all materials, equipment, labor, tools, storage, shipping, and incidentals necessary to modify the existing software, install CCTV software on City Transportation Department workstation, complete system integration, and provide a complete operating system.

Payment will be made under:

| Pay Item | Pay Unit |
|----------------------|-----------------|
| Modify CCTV Software | Lump Sum |

◆ **Revision No. 1, April 10, 2017 - This document supersedes version originally issued and sealed by J. Todd Brooks, NCPE No. 017586 on 12/28/2016**

37. SIGNAL SYSTEM SOFTWARE

37.1. DESCRIPTION

Furnish and install traffic control system software for the following applications:

- Distributed Processing System Software
- System Support Software

Install the following software as furnished by the Engineer:

- Local Controller Software (latest IP version of NCDOT's OASIS[®] software package)

The Contractor shall be responsible for the development of and integration of all system graphics (and associated system devices) described in the following specifications.

37.2. FUNCTIONAL REQUIREMENTS

A. General

The overall architecture of the system shall be a client server design based on hybrid centralized/distributed intersection control concepts.

Processing shall be distributed and OASIS[®] communications protocol shall be used for all intersection controller interfaces. Client workstations shall access networked file servers that perform traffic management, system communications, database management, and system graphics.

The system shall be implemented using standard, commercially available computer hardware required in the "Computer Hardware and Peripherals" section of these Project Special Provisions. Windowing graphical user interfaces (GUI) using object-oriented design and geographically coded database components shall be an integral part of the system design. These elements shall form the basis of all user interactions with the system.

The software shall be portable, as a minimum, across multiple PC hardware platforms and shall be designed to integrate with off-the-shelf PC software. For example, the system shall provide the ability to exchange files with common Geographic Information Systems (GIS), databases, and the latest version of Microsoft[®] Office.

All software and firmware furnished under this project (both for individual field equipment locations and for central software) that maintain internal clocks and utilize those clocks for display of time, reporting of time back to system users, reporting of time on reports and event logs, and/or use of internal time clock to coordinate actions and activities with other software or devices shall be able to adjust to leap-year and current day light savings time dates automatically without user intervention or adjustment.

1. Local Area Network Requirements

A 10/100/1000 Base-T Ethernet, local area network (LAN) shall support the distributed client/server architecture. The requirements for the LAN are in "Communications Hardware" section of these Project Special Provisions.

The software shall allow for a minimum of sixteen (16) simultaneous users (including remote users) of the traffic signal system applications software. No degradation in system performance

◆ **Revision No. 1, April 10, 2017 - This document supersedes version originally issued and sealed by J. Todd Brooks, NCPE No. 017586 on 12/28/2016**

U-4715B**ITS-252****Buncombe County**

shall occur when sixteen operators use the system simultaneously. Each user, subject to his or her security level, shall have full access for system control, database entry/examination, malfunction diagnosis, system operation evaluation and measures of effectiveness analysis. Access by any particular user to any particular command shall be allowed or disallowed based upon that user's assigned security level.

2. Software License

Provide a perpetual, irrevocable software license to the Department and the City of Asheville that gives them the right to copy and use the distributed processing software furnished with this project at any facility within the signal system limits.

Furnish software modifications necessary for system operation as per this Project Special Provision to the agency at no additional cost during the warranty period.

Furnish software that may be used at the NCDOT Division 13 TMC and the City of Asheville Transportation Department, NCDOT Division 13 Office, or at any other offices in the State of North Carolina that the City and State, or their authorized agent, may establish for the purpose of traffic signal monitoring and control of the Asheville Signal System.

For any software functionality that is specifically developed for this project, the software developer shall provide hardcopy and digital copies of the un-compiled source code of the software. This source code must be fully documented and commented, so that an experienced (minimum of 3 years) programmer/developer in the language(s) that the software is written may interpret, modify, and debug the code. The required software compilers shall be specifically and clearly identified and include the operator system platform, the version number, release number and date, and brand.

For copyrighted commercial off-the-shelf (COTS) software, a copy of the source code (both hardcopy and un-compiled digital commented as described in the preceding paragraph) shall be held in an escrow account by an independent agent agreed to prior to final acceptance of the system by the Department. The version of the source code in the escrow account shall be updated as modifications, fixes, enhancements, and improvements are made to the software and implemented on the software products used by the Department. In the event the provider of COTS software product(s) defaults, discontinues support of the software product(s) furnished under this project, goes out of business, or otherwise is unavailable to support the software product(s), the software source code contained in the escrow account shall immediately become the property of the Department.

Provide any third party software licenses to the Department and the City of Asheville for software that may be used. Example: report-configuring, diagnostic, or monitoring software.

3. Operating System

The operating system for all server software provided under this project shall be Microsoft Windows Server® 2012, Microsoft SQL Server 2012 or newer. The operating system software for all workstations and laptops shall be Microsoft Windows® 7 Professional Edition. The release used shall be the latest revision with service packs available as recommended by the supplier of the system software.

The network operating system (NOS) shall be Microsoft Windows Server® 2008 or approved equal and must be compatible with the traffic signal system software.

◆ **Revision No. 1, April 10, 2017 - This document supersedes version originally issued and sealed by J. Todd Brooks, NCPE No. 017586 on 12/28/2016**

U-4715B**ITS-253****Buncombe County**

The NOS shall be compatible and work seamlessly with the traffic signal system software and all other software (video, cellular, productivity, LAN, etc.).

4. Software Standards

The software shall use NTCIP Standards 1201 and 1202. The central to field device communications shall utilize NTCIP 1202.

5. Software Updates

Furnish the version of system software at the time of installation. Provide a means to automatically update the system software to all workstations, laptops in the network after new versions are installed on the server.

B. Distributed Processing Signal System Software

1. General

The signal system software shall not be a prototype or software custom-developed for this project. The software shall have been successfully integrated, tested, and accepted in at least two cities of comparable size (a minimum of 100 intersections). This deployment shall be with 2070 controllers utilizing the local controller software to be deployed under this project.

The system software shall communicate directly with the local intersection 2070 controllers installed under this project. The use of remote communication units (RCUs) is not permitted. The signal system software shall interface with the latest IP version of NCDOT's OASIS[®] local controller software package. The system shall use a client-server design based on hybrid centralized/distributed intersection control.

The Contractor shall demonstrate to the Department that the system software is capable of communicating with 2070E controllers produced by at least three different manufacturers on at least three channels.

The system shall be designed to operate 24 hours per day, unattended, with operator attention required only periodically. Operator intervention requirements shall be limited to defining system components, modifying system timing, responding to alarms or malfunction indicators, diagnosing component failures, and manually "fine-tuning" new timing plans.

The software shall provide central monitoring of up to 500 intelligent controllers. The system design shall accommodate future expansion. The addition of new intersections and detectors, in the field, shall not require additional software or central hardware, except for modems or transceivers and shall require only modification of the control database. The software design shall facilitate the easy, future incorporation of additional control strategy, software logic, and additional system features.

All changes to the system, including adding new controllers, configuring communications, modifying maps and intersection displays, etc., shall be performed through the system graphical user interface and by updating files in the system software folders. The use of initialization files and external editors shall not be required.

A laptop utility program shall provide on-street accessibility to off-line controllers.

2. Start-Up and Shut-Down

The traffic control system shall provide for the initial start-up of the system by initializing all operational and failure arrays within the software. The initialization routines shall be used not

◆ **Revision No. 1, April 10, 2017 - This document supersedes version originally issued and sealed by J. Todd Brooks, NCPE No. 017586 on 12/28/2016**

only at the true initial start-up of the system, but whenever it is desired to reinitialize the system without prior status information.

The traffic control system shall accommodate a planned shutdown of the monitoring functions of the traffic control software.

3. Power Failure

Interface system software with the uninterruptible power supply. Upon detection of a loss of power, the system software shall notify the operator.

The traffic control program may suddenly stop execution for various hardware or software reasons. In such event, alarms shall alert the operator as to the problem and circuitry shall ensure against the transmission of erroneous data by the field communications subsystem.

In the event that the operator determines that the operation of the system is improper, he/she shall be able to immediately force all system intersections to an off-line, or a time-based coordination timing plan stored in the local controller (depending on the local day plan) from any system workstation.

4. Backup Intersection Operation

The system shall provide for backup intersection operation in case of failure of the ITS Application Server, ITS Communications Server, or the communication system. This backup shall be accomplished by means of time-based coordination (TBC) provided by the local controller software.

When operating by centrally controlled scheduled events, the local controllers shall automatically implement local TBC, according to the day plan programmed into the controller whenever communication to central is absent.

When operating by centrally controlled manual commands, the local controllers shall continue to run according to those commands regardless of the state of communications.

5. Clock Updates

Upon login, each workstation clock shall be automatically updated by the Microsoft Windows operating system to the current time of the distributed system server clock.

6. Remote Access

The system shall allow full access to the system for a multiple user by means of Ethernet access through a secured firewall, using VPN or other means approved by the Department. The remote user shall be allowed to perform any functions, permitted by Terminal Services, and available to any other user with the same level of security regardless to where the user is physically located.

7. Paging

The system shall be capable of automatically sending alphanumeric messages (SMS – text messaging) to cellular telephones, smart phones and email addresses upon detecting problems with the system or from any device. Malfunctions notifications shall also appear as a pop-up alarm, or similar notification approved by the department, on each workstation logged into the system. An audible alert shall be associated with a pop-up alarm, and configurable by the user.

The visual pop-ups and audible alerts shall be configurable to stay up for a specified time period or to stay up indefinitely until closed by the user. Malfunction notifications shall consist

◆ **Revision No. 1, April 10, 2017 - This document supersedes version originally issued and sealed by J. Todd Brooks, NCPE No. 017586 on 12/28/2016**

U-4715B**ITS-255****Buncombe County**

of at least three (3), user configurable, priority levels, to include low priority, medium priority and high priority alerts. Acknowledgements of incoming malfunction alarms shall be required for all medium and high priority on-screen notifications. Low priority alarm notifications shall not require acknowledgements.

Malfunction alerts shall be sent via text (SMS) or email notifications and shall be configurable by TOD/DOW, allowing recipients to be selected based upon severity or priority of event and to issue text/email messages sent to multiple devices or addresses.

Notifications shall allow a confirmation to assure that the malfunction has been acknowledged. If no acknowledgement is received upon expiration of a user programmable time-out period, subsequent notifications shall be configurable to be sent to alternate devices.

The system shall log all malfunction notifications, retries, and acknowledgements with time and date stamps. The first acknowledgement shall be recorded; all others shall be ignored.

8. Field Communications

Within the Asheville computerized signal system, traffic signal controllers will be integrated with field Ethernet edge switches that are arranged in a multi-drop communications channels capable of supporting a minimum twenty (20) traffic signal controllers on a dedicated communications channel. The software shall operate with a fully redundant communications network. Each controller is connected to the system via a pair of optical fibers and field Ethernet switch. A channel consists of two fibers: one transmitting and the other receiving. The field communications will also include Ethernet radios operating at 900 MHz.

Each channel with its boundaries and the controllers and CCTV cameras contained within it are depicted on the cable schematic diagram shown in the Plans.

9. Database Preparation

Complete all data entry necessary to implement the operation of the system software.

The Engineer will furnish intersection timing information and coordination parameters (cycle, split, offset). Any custom intersection displays will also be provided by the Department or City. Otherwise, default intersection timing data and standard intersection maps will be utilized when configuring intersections onto the system. Program all system detectors shown in the plans. Coordinate with the Department to provide setup, naming/labeling, logging and any features required for the operation of all system detectors.

TOD/DOW plans, alarms and other information for the operation of the signal system shall be entered by the Contractor.

10. System Function Monitoring

Verification of on-street system operation shall be incorporated in the new signal system. Operation of all controller equipment shall be monitored, with current displays and malfunctions reported in near real-time. Continuous, polled communication shall occur from the local controller to the communication server.

11. Database Backup and Restoration

The system shall have a simple means of copying the database files from the hard disk to a removable storage device or archive server. All files required to restore the system to operation without the need to manually re-enter data shall be included on removable storage device.

◆ **Revision No. 1, April 10, 2017 - This document supersedes version originally issued and sealed by J. Todd Brooks, NCPE No. 017586 on 12/28/2016**

Files containing records of logged events and detector data shall be saved on a RAID array disk storage as described in the “Computer Hardware and Peripherals” section of these Project Special Provisions. The system shall enable an operator to copy all logged events, within a user-specified date range, to the removable storage device or archive server. The system shall enable an operator to copy all selected detector data to the removable storage device.

The software shall provide simple, straightforward means for restoring system operation from the backup database files.

12. Graphical User Interface

An object-oriented, graphical user interface (GUI) shall be provided to control and access all systems displays, reports, and dialogue boxes. The GUI shall provide access to all signal system monitoring and control options from a single screen.

Graphical icons shall be used on the displays to represent system devices. The icons shall provide easy access to traffic control data (signal timing, geometric, etc.), real-time data (intersection, link status, etc.), the database, and graphical image files.

The GUI shall include an intersection/link base map with windowed table reports and management input windows. The GUI shall provide interactive mechanisms to assist in creating, editing, and modifying editable dynamic graphic screens that are linked to system dynamic elements. As a result, all operator actions shall be immediately visible as a change in the system graphic.

The workspace session window shall display a toolbar near one of the window borders. The toolbar shall contain buttons and other controls specific for actions relating to a selected window. Actions supported by and pertaining to an active window shall be invoked through the toolbar, action bars, menu selection, popup menu or controls internal to the window itself.

Menu and dialogue box options that are not appropriate in a particular context or not available to a given user shall be “grayed-out” and unavailable for selection.

Traffic engineering terminology shall be used throughout the programming displays. Display organization and data entry approach shall allow system operators to operate the distributed signal system software without using reference cards or manuals.

The user interface shall include an object library that contains dynamic icon objects for system control and monitoring devices. The basic system shall include, at a minimum, objects for traffic signals (OASIS[®]).

The library shall also include an interactive editor for placing these objects within dynamic graphic screens.

The system shall allow the user to link dynamic graphics objects directly to system database elements without low-level code programming, use of initialization files, or program recompilation. The library shall also include dynamic objects allowing the user to define directional roadway links using a simple vector drawing facility. Proper representation of directional status attributes shall be available at all zoomed levels, on the system map.

All information shall be shown simultaneously and continuously displayed until canceled by the operator. Displays shall not affect system operation. All displays shall have a maximum refresh rate of one second.

◆ **Revision No. 1, April 10, 2017 - This document supersedes version originally issued and sealed by J. Todd Brooks, NCPE No. 017586 on 12/28/2016**

U-4715B

ITS-257

Buncombe County

System Graphics

These dynamic condition maps shall provide a simple mechanism for system navigation, presentation of status, and selections within the user interface.

Backgrounds for the system-wide graphic shall be capable of containing commercial vector images of geographically accurate maps or scanned images. These images shall be compatible with common GIS packages such as ARCGIS. These images shall be used as the display layers of real-time graphics displays. The graphics for the entire system shall be developed in the ESRI map objects embedded environment, or approved equivalent.

Backgrounds for the control section and intersection displays shall be .bmp or .jpg formats. Resolution or file size shall not be limited.

Zooming, scrolling and automatic control layers of graphic presentations shall be included with the system.

All graphics for system maps, control section maps, and intersection displays shall be submitted to the Engineer for approval before being integrated with the software.

System Map

The ESRI-based system-wide map or approved equivalent shall provide a dynamic display of the entire surveillance area and any layers the agency requires, including but not limited to interstate highways, major arterial roads, railroads, jurisdiction boundaries, and bodies of water. It shall be possible to “zoom in” and “drill down” to any specific area of the map using the pointing device to select one corner of an area to view, and then select the opposite corner of the area to view. (Zoom out capability shall also be provided). The window containing the system-wide map shall be capable of being dynamically sized by a workstation user.

It shall be possible to display intersection icons in different formats, using the menu bar. The system map shall provide a dynamic display of the signal system signalized intersections in the following two modes:

- Intersection phasing
- Intersection plan

The graphic shall also dynamically display the status of the controllers (e.g., coordination, emergency vehicle preemption, railroad preemption, transition, free operation, flashing, failure, intersection phase status). Intersection status and roadway links shall change color dynamically based on user definable color selection.

Intersection phase status (green, yellow and red) shall be displayed in real-time on the intersection phasing icon. The intersection control status shall be displayed as the background color on the intersection plan icon. Intersection plan information shall be displayed as a number on the intersection plan icon.

Link status shall be shown as different (user defined) colors for differing traffic flow conditions.

The system display shall be capable of being dynamically sized by a workstation user. Resizing the window shall not reduce the amount of data displayed on a workstation monitor and the same aspect ratio shall be monitored as before the resizing.

◆ **Revision No. 1, April 10, 2017 - This document supersedes version originally issued and sealed by J. Todd Brooks, NCPE No. 017586 on 12/28/2016**

Control Section Map

Create default subsection maps/zones or areas to provide a display. The default displays will be called control section maps, and shall provide a more detailed display of selected zones or areas of the system. A control section shall be able to be called from the system map display via a double mouse click or from a drop down menu. A minimum of fifteen (15) control section displays shall be capable of being simultaneously displayed while the system map is open and the maximum number intersection display windows are open. The control section map interface shall be an integrated portion of the distributed processing system software and shall not be a stand-alone package.

The control section map shall provide a dynamic display of the signal system, including landmarks, streets, signalized intersections, interstate highways (if applicable), railroads (if applicable), system detectors, system detector actuation. Labels for these items shall also be displayed. All labeling shall be approved by the Engineer. The graphic shall also dynamically display the status of the controllers in the sub-area (e.g., coordination, emergency vehicle preemption, railroad preemption transition, free operation, flashing, failed, intersection phase status). Volume and occupancy levels shall be displayed as color bars on the map. Intersection phase status (green, yellow, and red) shall be displayed in real-time using arrow icons. Link status shall be shown as green for free flow or near free flow conditions. Yellow shall be shown for moderate congestion or transition conditions. Red shall be shown for congested conditions, and flashing red shall be used to indicate severe congestion or major delays. The control section display shall be capable of being dynamically sized by a workstation user. Resizing the window shall not reduce the amount of data displayed on a workstation monitor, and the same aspect ratio shall be monitored as before the resizing. The control section map graphic shall include a user-definable control section map title. North shall either be at the top or right side of the monitor when displaying a control sub-area. Vertical and horizontal scroll bars may be provided if the size of the sub-area is such that it cannot be displayed on a monitor at a scale (as determined by the Engineer) that is adequate for viewing by the operator. Refer to the System Detector Schematic in the Plans for control section boundaries and numbering. There will be a maximum of 30 control section Map displays. Submit a sample of a control section display or map for review by the Engineer.

Intersection Display

The intersection graphic shall display both static and dynamic information. The static information shall include the intersection name, geometrics of the intersection (including a graphic display of the number of lanes and their associated use), adjacent land use, the location of the controller, and a layout of the intersection with the intersections signal locations and number of heads. The dynamic information to be displayed shall include:

- All vehicle signal indications for each active phase, and up to sixteen (16) overlaps with red, yellow, and green indicators
- All pedestrian signal indications, for up to sixteen (16) active phases. WALK, flashing DONT WALK, and steady DONT WALK shall be shown
- Vehicle and pedestrian detector actuations for each active phase

◆ **Revision No. 1, April 10, 2017 - This document supersedes version originally issued and sealed by J. Todd Brooks, NCPE No. 017586 on 12/28/2016**

U-4715B

ITS-259

Buncombe County

- Cycle timer (central and local clocks)
- Timing plan in effect (with cycle length and offset)

Operational status of the intersection shall include the following, but not be limited to:

- Timing in effect (in coordination, TOD, TR, etc.)
- Status mode (transition, free operation, flash, preemption (railroad or emergency vehicle))
- Control mode (manual control, local control, failed, etc.)

The intersection display shall accommodate all OASIS[®] phasing.

The intersection display shall be capable of being dynamically sized by a workstation user. Resizing the window shall not reduce the amount of data displayed on a workstation monitor.

13. Intersection Monitoring

The status of each controller shall be monitored and any detected error condition shall be logged. Error conditions shall be stored in a form that specifies the type, date, and time of the error. Error processing shall be performed during both coordinated and free operations.

The software shall monitor for the following conditions:

Communications Status

The system software shall report the present status of the communication system at the controller. Changes in status of the communication system shall be recorded in the system log.

Communication Error

If communication between the communications server and local intersection is lost for a number of consecutive seconds, a failure shall be identified and an error message shall be logged and the intersection shall be dropped from system monitoring. Upon identification of a communications error, the software shall continuously attempt to re-establish communications to the intersection and regain monitoring of the intersection.

Flash Conditions

The system shall have the following flash mode capabilities:

- **Central Flash:** Individual intersections and control sections shall be capable of being placed on flash by operator command or schedule entry.
- **Cabinet Flash:** Cabinet flash mode shall be indicated when a controller enters flash via manual selection at the cabinet.
- **Conflict Flash:** Conflict flash shall result from a tripped conflict monitor at the local intersection. Conflict flash shall be logged as a failure by the software system.

The type of flash mode (central, cabinet, or conflict), the intersection name, date and time shall be logged for each entry or exit from flash.

◆ **Revision No. 1, April 10, 2017 - This document supersedes version originally issued and sealed by J. Todd Brooks, NCPE No. 017586 on 12/28/2016**

U-4715B**ITS-260****Buncombe County***Local Preemption*

The system shall monitor and recognize the occurrence of preemption at each local intersection. Accordingly, a preempted intersection shall not be erroneously diagnosed as having experienced a coordination failure. System log messages shall be recorded to note the beginning and ending times of local preemption and the type of preemption (e.g. emergency vehicle, railroad, etc.).

Implemented Local Manual Control

Local manual control shall be initiated and controlled by hardware at the intersection. The software shall identify any intersection that is in local manual control by means of a status message. Accordingly, an intersection being operated under manual control shall not be erroneously diagnosed as having experienced a coordination failure. When the local manual control status has been removed, the local software shall initiate the transition back to normal operation and the system log messages shall be recorded at the start and end of local manual control condition.

Local and System Detectors

The system shall allow users to set up and gather detector data from local and system detectors for traffic responsive operation or other analytical purposes.

The software shall be able to recognize and report failed detectors (e.g. constant call, no calls, etc.). A detector shall be automatically suspended from use if it is failed. Parameters for determining under counting, over counting, maximum presence shall be adjustable by the user. Detectors classified as marginal shall remain in use, but shall be identified. A change in classification to either failed or marginal and the reason for the change shall be reported to the operator and automatically entered in the system log. A reclassification to acceptable shall also be logged. System detector activity reported from any local controller type shall be monitor for under counting, over counting, and maximum presence.

Regardless of the classification status of any detector, detector status reporting shall continue unless inhibited by an operator command. A detector that has been suspended from use due to a failure shall remain suspended until its operation has been reclassified as either acceptable or marginal, or until the operator enters a command that releases it from suspension.

Detector data smoothing shall be provided to prevent short-term fluctuations from incorrectly influencing traffic-responsive control algorithms. The system software shall automatically use historical data for the traffic-responsive control algorithms when detectors have been classified as failed.

Timing Plans

An intersection timing plan shall be defined as a unique combination of cycle length, split and offset at an intersection. The software shall monitor a minimum of sixty-four (64) timing plans for OASIS[®] controllers. In addition, the software shall enable selection of both flashing and free operation of any intersection.

Cycle lengths, offsets, and splits shall be reported in one-second increments, or as a percentage of the cycle length if selected by the user.

◆ **Revision No. 1, April 10, 2017 - This document supersedes version originally issued and sealed by J. Todd Brooks, NCPE No. 017586 on 12/28/2016**

Whenever a new timing plan is implemented, each controller shall achieve the new offset by implementing a transition with respect to the new cycle clock reference. For each intersection on the system, the software shall recognize and display a message that local transition is in effect.

Phase Movements

The system shall monitor each independent movement of up to sixteen (16) phases, for the quad-ring OASIS® controller. This monitoring shall include force off points, and permissive periods for each phase.

Clock Updates

Following each update of the clock on the communications server, the system shall update the clocks in each local controller and the distributed system server.

The system shall be able to receive clock updates from an external time synchronization source. Clock updates shall be demonstrated and approved by the Engineer. The system shall broadcast, unicast, or use a combination of both to send time updates to controllers on a user-configurable schedule. The user shall be able to configure how often the broadcast is performed, the hour at which the broadcast begins, the number of times the broadcast is repeated, and the time period between repeated broadcasts.

The system shall provide a means of monitoring the time drift of clocks on controllers, provided the controller supports this functionality.

For each controller that supports this functionality, the system shall allow checking controller clock times on a user-specified interval.

The system shall display the time the controller's clock was last checked and the difference between that controller clock and the system time reference.

The system shall also provide the ability to automatically synchronize a controller's clock if the time drift exceeds a user-specified threshold.

The system shall provide a means to synchronize controller clocks with the system time reference upon user command.

This functionality shall be provided in addition to the scheduled time broadcasts previously specified.

14. Intersection Control

The software shall allow any user to control and implement changes to any intersection controller via the GUI, either through scheduled events, manually controlled events, or time-of-day plans programmed in the local controller. All parameters and events that can be programmed from the controller front panel shall be available at central for remote implementation. Any aspect of the controller timing shall be assessable from central, and shall allow editing of all timings. Full upload and download of timings to controllers shall also be allowed.

Central Scheduler

It shall not be necessary to use a special function to implement any of the local controller's basic functions. These functions shall be inherited from the timing plans associated with each type of controller.

◆ **Revision No. 1, April 10, 2017 - This document supersedes version originally issued and sealed by J. Todd Brooks, NCPE No. 017586 on 12/28/2016**

U-4715B

ITS-262

Buncombe County

The system shall include a centrally based event scheduler that issues scheduled commands to local controllers. The set of schedulable events shall include:

- Coordination Plans
- Software Flash
- Free Operation
- Local TOD
- Traffic Responsive Operation
- Holidays
- Special Functions (supported by local controller type, including one-time events)

The event scheduler shall support the following features:

- **Day Plans:** The scheduler shall support scheduling of up to 100 unique day plans. Each day plan shall support up to 100 individually schedulable events. The individual events shall be implemented for a specific controller or a control section. The time resolution of each event shall be one minute.
- **Week Plans:** The scheduler shall support up to 52 week plans. Each week plan shall support individual day plan selection for each day of the week.
- **Annual Calendar:** An annual calendar shall support both week plan and individual day plan selection. The calendar shall automatically roll permanently scheduled events from one year to the next.
- **Individual Event Scheduler:** The scheduler shall support up to 500 Individual events to be scheduled at a higher priority than the Calendar events.
- **Manual Command/Temporary Event Scheduler:** The scheduler shall support implementation of temporary events. These events shall be programmed to begin immediately or within a scheduled timeframe. These events shall be automatically deleted from the system upon completion.

Time-of-Day Operating Mode

The Time-of-Day/Day-of-Week/Day-of-Year (TOD/DOW/DOY) mode of operation shall allow the advance scheduling of the signal plan and timing plan to be implemented in each section. TOD/DOW/DOY scheduling shall be performed based on the schedule data stored locally at the controller and updated by upload/download operations.

Coordination Plan and Scheduler Resolution

Events in the scheduler (both turn-on and turn-off) shall be adjustable in minimum increments of one minute.

Section (Zone) Control

The software shall achieve coordinated operation across the boundaries of all control sections operating on the same cycle length or on multiples of the same cycle length by ensuring that all such control sections are synchronized to a common reference.

◆ **Revision No. 1, April 10, 2017 - This document supersedes version originally issued and sealed by J. Todd Brooks, NCPE No. 017586 on 12/28/2016**

Timing plan selection shall not be limited to entire sections. Timing plans, at the discretion of the system operator, shall be implemented for a single intersection, section of intersections, or system-wide. The timing plan shall be selectable by the operator (Manual mode), by a time clock scheduler (Time-of-Day/Day-of-Week mode), or by the local controller itself.

Traffic-Responsive Operation

In traffic-responsive operation (TRO), the system software implements a V+kO, threshold matching algorithm, and shall select the timing plan based upon system detector information and coordination threshold parameters that have been defined by the user.

The system database shall identify the system detectors that are assigned to each control section for traffic-responsive operation. System detectors may be assigned to more than one control section.

In traffic-responsive operation, the software shall use weighted volume and occupancy from the active system detectors. When the system is running TRO, it shall monitor the control section for failed detectors. Upon detection of failed detectors, TRO will continue to function until the percentage of failed detectors exceeds an operator-specified threshold. The section shall then automatically switch to the TOD/DOW/DOY timing plan. This plan shall remain in effect until the percentage of failed detectors is below a different operator specified threshold. At this time traffic-responsive operation shall automatically resume.

Minimum plan execution time and threshold hysteresis shall be established by the operator to prevent excessive switching between timing plans. The minimum time between timing plan changes for any given section shall be measured in one-minute increments; this value shall be separately defined for each section.

The user shall have the ability to run traffic responsive as a background process wherein a traffic responsive plan is selected, but not implemented. This shall allow the user to verify traffic responsive operation in an off-line mode.

15. Database Management

The system shall be built around a multi-user commercial off-the-shelf (COTS) database software product. The database shall be used to store, retrieve, and maintain system data and parameter files and shall be available for common computer hardware platforms. The database system shall use structured query language (SQL) and conform to Microsoft's open database standards.

The software shall provide user-friendly database facilities that allow changes to be put into effect while the system remains fully operational. The system shall provide the following database management features.

The database management software shall allow programming of the intersection controller databases. Each intersection controller shall have separate database programming pages. These pages shall contain all the programming options unique to each intersection.

All programming entries shall primarily consist of numerical values, "Yes" or "No" entries, and bit data. During configuration data entry, the new data shall overwrite the old data. If the data is in error, changes shall not be permitted and the user shall be alerted by either an error message on the display or a warning tone.

◆ **Revision No. 1, April 10, 2017 - This document supersedes version originally issued and sealed by J. Todd Brooks, NCPE No. 017586 on 12/28/2016**

U-4715B

ITS-264

Buncombe County

All data items entered from any workstation shall be tested for data type (numeric or text) and allowed range. All string data items shall be tested to ensure that they do not exceed the allowed length. The program shall not terminate because any data item is incorrectly entered. When errors or potential errors are detected, the program shall either display a specific diagnostic message on the screen or shall give an audible alarm and shall place the cursor in the proper field. In any case, the system shall allow the operator to re-enter the item. Prior to or simultaneously with reentry, the diagnostic message, if any, shall be erased.

Whenever a logical grouping of data (such as a full screen or the complete database file) has been entered or edited satisfactorily, that data shall be written to the proper record. This may take place upon return to the main menu or, alternatively, it may take place as the entry or editing of each distinct file is ended.

The screen organization and data entry/edit method shall enable the operator to use all functions without the need to use reference manuals or cards. The software shall minimize the use of mnemonics to interface with the user on the screen, in printed reports, and in the system's documentation or worksheets. Only mnemonics consisting of Engineer approved traffic engineering abbreviations and other straightforward abbreviations shall be acceptable.

All field descriptions and inputs shall be simple and all text shall be in simple English and common traffic engineering terminology. It shall not be necessary to perform any decoding to read the information. All necessary field descriptions shall be specifically and discretely provided on the same display screen as they are needed.

Copy Facility

It shall be possible to copy an entire controller database (except for intersection name and identification number) from one controller database to another controller database.

It shall be possible to copy from within the database software all logical segments of the controller database to other like segments of the same controller database using menu commands (IE Timing Table page 1 → Timing Table page 2).

It shall be possible to copy from within the database software all logical segments of the controller database to other like segments of another controller database using menu commands (IE Timing Table page 1 [intersection 100] → Timing Table page 2 [intersection 101]).

It shall be possible to copy from one cell within a database table to another like cell in the same table (IE min green phase 1 to min green phase 2).

Upload/Download of Database

Any workstation shall provide for uploading (copying) the database, and logical segments thereof, from any OASIS[®] local controller. The software shall similarly provide for downloading (copying) the database, and logical segments thereof, to a 2070 controller using OASIS[®] firmware from any workstation.

Uploading a controller database from the field to central (or downloading from central to the field) from one type of controller to another type shall not be permitted.

The upload/download feature shall use block transfer techniques with a cyclic redundancy check (CRC) to ensure data integrity. Non-verified data shall cause termination of the upload or

◆ **Revision No. 1, April 10, 2017 - This document supersedes version originally issued and sealed by J. Todd Brooks, NCPE No. 017586 on 12/28/2016**

U-4715B**ITS-265****Buncombe County**

download operation, with no transfer of the corrupted block occurring. A status message shall be displayed when improper termination of the upload or download operation occurs.

Database Comparison

Following an upload, the system shall allow the operator to compare the database of any intersection controller to the database stored for that intersection on the file server. This comparison shall identify any differences between the uploaded and stored file data. The system operator shall be able to correct, use, or substitute data values and proceed with further comparison. Provide a means to view/locate stored data on file server.

16. Reports

The system shall generate a number of pre-configured reports. The database software shall permit the operator to use structured query language (SQL) to retrieve data and produce pre-configured reports. System report information shall be able to be exported to a XML file with report data, CSV (comma delimited), PDF file, TIFF file or a Microsoft Word file. All reports should show asset ID number, main street, cross street, asset type and prevalent information to the asset.

The formats (samples) of all pre-configured reports shall be submitted to the Engineer for approval.

The list of pre-configured reports shall include, but not be limited to, the following:

- System Errors/Alerts
- Communications Status Online/Offline
- System and Local Detector VOS Data
- Device Communications Configuration
- Device Configuration
- Events Log
- Control Section/Links Data
- Scheduler
- Signal Changes
- Signal Detector Events
- Split Monitor
- System Activity
- System Events
- Time Drift
- Upload and Compare
- User Login
- Detector VOS

◆ **Revision No. 1, April 10, 2017 - This document supersedes version originally issued and sealed by J. Todd Brooks, NCPE No. 017586 on 12/28/2016**

U-4715B**ITS-266****Buncombe County**

- Daily
- Hourly
- Multi-date / Hourly
- Multi-date / Daily

Use of third party software for the development of custom reports shall be provided by the Contractor. The software shall interface with the signal system software and its data base to allow the user to create custom reports. The user shall be able to define the format of those reports. The system shall also provide a means by which user-specific reports can be created and added to the Reports menu item without the requirement of additional software or custom development work by the software provider.

Training shall be provided on the editing, creation, exporting and general use of pre-configured and custom reports.

17. Security

In addition to the network security features provided by the operating system, the software shall provide customizable levels of access security. Each user must enter a login name and password before gaining access to the software.

The system shall accept any number of users to be configured onto the database. The system shall have three default levels of security, as follows:

- Admin User
- Read Write
- Read Only

The top level (Admin User) shall provide for total access (i.e. permit the operator to view and change all information in the system). Only users with this authorization shall be permitted to view or change access security codes, add new users and delete existing users.

A bottom level (Read Only) shall permit viewing of all information (except access security codes) yet not permit the operator to make any changes to the database.

The system shall also provide the ability to customize each user's privileges with respect to system functionality. Privileges can also be defined with interjurisdictional rights. Specific privileges shall be configurable for each user, with respect to each of the following System Permissions:

- User Setup (Admin User Only)
- Asset Group
- Location
- System Preferences
- Archive Logs
- Export Logs
- Restore Logs
- Purge Logs

◆ **Revision No. 1, April 10, 2017 - This document supersedes version originally issued and sealed by J. Todd Brooks, NCPE No. 017586 on 12/28/2016**

U-4715B**ITS-267****Buncombe County**

Specific privileges shall be configurable for each user, with respect to each of the following Traffic Permissions:

- ITS Communications Server Setup
- Detectors
- Sections
- ICM Port Configuration
- Scheduler
- Traffic responsive
- Time Space Diagram
- AEM
- W4 Special Functions
- Traffic Preferences

Specific privileges shall be configurable for each user, with respect to each of the following alarm assignments:

- Central Communications Failure
- Field Communications Failure
- Technician Flash
- Monitor / Conflict Flash
- Controller Error
- Stop Time
- Detector Failure
- Police Switch
- Door Open
- Local Clock Failure
- Special Function 1
- Special Function 2
- Special Function 3
- Special Function 4

Each user shall have separate privileges to each asset group (a group of intersections defined within the system, which may cross jurisdictional boundaries, allowing multiple agencies to use a single system). Specific privileges shall be configurable for each user, with respect to each of the following asset group functions:

- Properties
- Delete
- Graphics Editor
- Timing Tables
- Upload

◆ **Revision No. 1, April 10, 2017 - This document supersedes version originally issued and sealed by J. Todd Brooks, NCPE No. 017586 on 12/28/2016**

U-4715B**ITS-268****Buncombe County**

- Download
- Manual Commands
- Real Time Clock

18. Help

The signal system software shall have comprehensive, online help screens. The help screens shall be context sensitive, providing information specific to the highlighted fields or windows displayed.

C. Local Controller Software

Local controller software shall be the latest version of the NCDOT-approved controller software. The Engineer will furnish the latest version of the software at the time of burn-in. Request the software from the Engineer a minimum of five business days prior to burn-in.

D. System Support Software and Devices**1. Devices**

Furnish one (1) Garmin eTrex Legend GPS Receivers, or approved equivalent, with Cigarette Lighter Adapters (#010-10203-00).

2. Productivity Software

Furnish a network version of the latest release of the Microsoft Office, Professional Edition, including Excel, Access, Word, and PowerPoint. A license shall be provided for each workstation and notebook computer furnished with the project. Furnish and install a copy of the latest release of Microsoft Office, Professional Edition, on each workstation and notebook computer furnished.

Include a complete user's manual and original installation disks or CD-ROMs for each software package. Provide full technical and maintenance support for all software.

3. Utility Software

Furnish utility software for uploading and downloading timing plans locally at the signal cabinet. Furnish software that is compatible with local controller software and signal system central software. Furnish software with printing functionality. Provide a copy of the utility software on all notebook computers furnished under this project. In addition, provide a copy of the utility software to the Engineer prior to Final Acceptance.

37.3. INSTALLATION AND INTEGRATION**A. General**

Install and fully integrate distributed processing signal system software on ITS Application Server called for in "Computer Hardware and Peripherals" section of these Project Special Provisions. Install and fully integrate distributed processing signal system software on each workstation and notebook computers in the Asheville traffic signal system.

Install and fully integrate distributed processing signal system software with the ITS Communications Server called for in "Computer Hardware and Peripherals" section of these Project Special Provisions as required.

◆ **Revision No. 1, April 10, 2017 - This document supersedes version originally issued and sealed by J. Todd Brooks, NCPE No. 017586 on 12/28/2016**

U-4715B**ITS-269****Buncombe County**

Install all software furnished for the system in accordance with the procedures recommended by the software supplier.

Install a copy of the distributed processing traffic signal system software and all communications software necessary to achieve remote operations on the notebook computers.

Register all software products furnished with this project with the software supplier. The City of Asheville and NCDOT shall be identified as the registered owner of all software.

B. Distributed Processing Signal System Software

Install and integrate the distributed processing traffic control applications software and all other software with the communications system and local controllers to provide a traffic signal system that provides the functionality required by these Project Special Provisions.

Load all parameters necessary to implement coordinated signal operations. The Engineer will furnish the timing parameters in standard traffic engineering format (cycle, split, and offset) prior to the initiation of the 60-day observation period. Make any modifications to the cycle, split, and offset information furnished by the Engineer that are necessary to implement the timing plans into the system database. The test period may not begin until the timing parameters have been loaded. The Engineer may, at his/her option, observe the loading of the timing plans.

As directed by the Engineer, make modifications to the coordinated signal timing parameters (cycle, split and offset) prior to system acceptance to improve system coordination and efficiency. The Engineer will furnish the parameters to be modified by the Contractor. Make these modifications at no additional cost. No timing plan changes will be required after the successful completion of the system operational test (as approved by the Engineer).

Prepare comprehensive, detailed graphic displays for the system display, for all control section displays, and for all intersection displays. Contractor shall install all displays and fully integrate with system software. Submit all graphics to the Engineer for approval prior to the System Operational Test and prior to integration in the software.

Program all new system detectors installed under this project, and all existing system detectors being reused, in the signal system software. Install all associated graphics related to system detectors. Integrate system detector locations (based on the actual installation in the field) on all associated system graphics.

Submit specific landmarks and features to be displayed in the section and intersection displays to the Engineer for approval. Develop each screen upon approval of the areas to be displayed by each screen and make revisions as required from review.

Provide training to City and Department personnel relative to the creation and editing of the sub-area and intersection displays as required in these Project Special Provisions.

C. Local Controller Software

Install NCDOT-furnished local controller software on all new controllers. Use the latest version available at the time of installation as directed by the Engineer. Request local controller software from Engineer a minimum of one (1) week prior to use of software during burn-in period.

All controllers in the final Signal System shall have identical local software.

◆ **Revision No. 1, April 10, 2017 - This document supersedes version originally issued and sealed by J. Todd Brooks, NCPE No. 017586 on 12/28/2016**

U-4715B

ITS-270

Buncombe County

D. System Support Software and Devices

Install software, devices, productivity software, and utility software on all workstations and notebook computers provided with the project.

37.4. TESTING**A. General**

Provide the following tests and demonstration of the system software:

- System Demonstration Test, if required (see below)
- System Operational Test (as called for in “Testing and Acceptance” section)
- 60-Day Observation Period (as called for in the “Testing and Acceptance” section)

B. System Demonstration

If the signal system software package proposed for this project has not been deployed for a state or municipal system in North Carolina, a system demonstration is required. Otherwise, the system demonstration requirements are considered to have been fulfilled under previous projects.

Within one-hundred (100) calendar days after award of the contract, demonstrate ability to provide a working traffic control system that will be in general accordance with these Project Special Provisions. This shall be accomplished by conducting a demonstration of the major elements of the traffic control software at an existing, operational traffic signal system somewhere within the United States or Canada, excluding Alaska and Hawaii.

The demonstration shall take place at an actual, operating traffic signal system that features software developed and furnished by the same vendor proposed by the Contractor for this project. The candidate demonstration system shall have actual functional performance that is similar to, or better than the system required by these Project Special Provisions. A minimum of thirty (30) days prior to this demonstration, the Contractor shall submit to the Engineer a detailed description of the features provided by the candidate demonstration system and a narrative discussion of how that system differs from the functionality required by these Project Special Provisions. The Engineer shall be the sole judge as to whether or not the candidate demonstration system is sufficiently similar to the one required for the Asheville System. All transportation, lodging and per diem costs for NCDOT and City personnel to witness the system demonstration will be borne by NCDOT or the City.

37.5. MEASUREMENT AND PAYMENT

Signal system software shall be measured and paid as a lump sum. This shall include the furnishing, installation, testing, and all materials, 3rd party software for reporting, equipment, labor, tools, storage, shipping, and incidentals necessary to install the software, complete system integration, and provide a complete operational system. Partial payment for this item will be made as follows: 50% of the lump sum price upon delivery and installation of the software and 50% of the lump sum price upon successful completion of the Observation Period. No payment will be made for providing software license and source code as required in these Project Special Provisions.

◆ **Revision No. 1, April 10, 2017 - This document supersedes version originally issued and sealed by J. Todd Brooks, NCPE No. 017586 on 12/28/2016**

U-4715B**ITS-271****Buncombe County**

System support software and devices shall be measured and paid as a lump sum. This shall include the furnishing, installation, and all materials, equipment, labor, tools, storage, shipping, and incidentals necessary to install and configure the software and provide a complete operating system. Payment for this item will be made as follows: 100% of the lump sum price upon delivery, installation and testing of the software into the appropriate hardware. GPS receivers will not be paid for separately but will be considered incidental. No payment will be made for providing software license and source code as required in these Project Special Provisions.

All other software and hardware otherwise required to accomplish the functionality required by these Project Special Provisions will not be paid for separately but will be considered incidental. No payment will be made for providing software license and source code as required in these Project Special Provisions.

Testing will not be paid for separately but will be considered incidental to equipment installation.

Payment will be made under:

| Pay Item | Pay Unit |
|-------------------------------------|-----------------|
| Signal System Software | Lump Sum |
| System Support Software and Devices | Lump Sum |

◆ **Revision No. 1, April 10, 2017 - This document supersedes version originally issued and sealed by J. Todd Brooks, NCPE No. 017586 on 12/28/2016**

38. COMPUTER HARDWARE AND PERIPHERALS

38.1. DESCRIPTION

Furnish and install all materials with the most recently developed and approved product versions that meet or exceed all applicable standards, specifications, and requirements before the system is considered for acceptance. Ensure that all equipment features, functions, and performance measures are met.

Furnish, assemble, fabricate and install new products obtained from the manufacturer or reseller. Provide commercial off-the-shelf materials, equipment, and components.

Furnish and install ITS servers and two computer workstations in the TMC and one computer workstation in the City Transportation Department. Install five laptops in the TMC and two laptops in the City Transportation Department for diagnostic work on the signals system. Ensure that all workstation and laptop computers can access the ITS LAN and can be used to monitor, interact, and control all critical input and output parameters of the traffic signal system and ITS devices.

A. ITS Servers

Furnish and install ITS servers in the TMC as described in the Plans and these Project Special Provisions. Furnish and install application servers (one primary signal system application server and one redundant signal system application server) and one communications server in the TMC. Connect the ITS servers in the TMC to the Ethernet core switch and to a UPS protected outlet.

B. Computer Workstations

Furnish and install computer workstations consisting of a CPU, two monitors, keyboard, UPS and mouse in the TMC and at the City Transportation Department.

C. Laptop Computers

Furnish and install laptop computers consisting of the computer, power supply, carrying bag, and mouse for use by Department staff in the TMC and City Transportation Department staff.

D. Printer

Furnish and install a color laser network printer for use in the TMC.

E. KVM Switch

Furnish and install a rack-mounted KVM switch assembly consisting of a monitor, keyboard, and mouse with switching hardware to control and access the servers supplied with this project.

F. UPS

Furnish and install uninterruptible power supply (UPS) units for the Ethernet core switch in the TMC. Each UPS shall also include any ancillary equipment or incidental items, such as required mounting hardware and cabling.

G. Existing Equipment

Remove existing computer equipment from the TMC noted to be removed in the Plans.

◆ **Revision No. 1, April 10, 2017 - This document supersedes version originally issued and sealed by J. Todd Brooks, NCPE No. 017586 on 12/28/2016**

38.2. MATERIALS

A. ITS Servers

1. Functional

The ITS servers shall integrate the workstations with other ITS systems and shall enable video and data accessibility and exchange between various systems. The servers shall function in automated fashion in unmanned mode supporting clients' control functions via ASN.1 and/or XML-defined protocols over TCP/IP. Provide the servers capable of operating in the following configurations:

- Single server configuration (environments with n*10 controlled objects).
- Multiple server configuration (environments with n*100 controlled objects).
- Thin server configuration (active control of local part in case of larger system).

Provide ITS servers meeting the following functional requirements:

- Handle commands from system clients via ASN.1 and/or XML defined protocol over standard TCP/IP connection.
- Command underlying nodes (devices such as encoders, video servers).
- Report status of system nodes and alarms.
- Monitor system nodes connections.
- Store recent alarms in internal database.
- Receive Simple Network Management Protocol (SNMP) traps generated by network infrastructure, translate SNMP traps as system alarms, and send alarms as SNMP traps.
- Support remote configuration and diagnostics.
- Restore video and connections in case of system component restarts.
- Support protocols: TCP, UDP, NTP and IP Multicast IGMP.

2. Performance

Provide ITS application and backup servers meeting the following minimum requirements:

- Chassis: Up to eight (8) 3.5-inch hard drives,
- Processor: Dual quad core Intel Xeon E5-2640 or better at 2.6 GHz or greater, QPI, HT, 8C/16T, 20 MB cache, Turbo 1866 MHz,
- Memory: Minimum 32 GB RDIMMS for two processors, 2133 MT/s x8 data width,
- Backplane: 1x6 backplane for 3.5 inch drives, expandable to eight drives,
- Power Supply: Dual, hot plug, redundant power supplies with separate cords,
- Riser: Riser with three x 8 PICE and one PICE x16 slots
- RAID Controller: PERC H730 RAID 5 (3-16 hard drives) with PCIe, 1 GB NV cache,
- Hard Drives: RAID 5 with 4 x 300 GB, 10k RPM, SAS, 6 Gbps 2.5 inch Hotplug,
- CD-ROM: DVD +/-RW SATA Drive, internal,
- Video Card: Integrated video chipset controller 8 MB SD RAM with 480 MB/s memory bandwidth and DirectX 5.0,
- Video Adaptor: SGVA,

◆ **Revision No. 1, April 10, 2017 - This document supersedes version originally issued and sealed by J. Todd Brooks, NCPE No. 017586 on 12/28/2016**

U-4715B**ITS-274****Buncombe County**

- Mounting: Slide ready rails and cable management
- Network: Quad-port Gigabit Network Adaptor with TOE, two x v 2.0, ACPI v 2.0, SMBus 2.0,
- Embedded Controller: Out of band management, iDRAC8 Express, integrated remote access controller,
- Operating System: Microsoft Server 2012, Standard Edition with 5 CALs, and
- Support Software: Microsoft SQL 2014, Standard Edition, with 10 CALs.

Provide one ITS communications server meeting the following minimum requirements:

- Chassis: Up to eight (8) 3.5-inch hard drives,
- Processor: Dual quad core Intel Xeon E5-2640 v3 or better at 2.6 GHz or greater, QPI, HT, 8C/16T, 20 MB cache, Turbo, 1866 MHz,
- Memory: Minimum 16 GB RDIMMS for two processors 2133 MT/s, single rank, x8 data width,
- Power Supply: Dual hot-plug and redundant, separate power cords,
- Riser: Riser with two PICE x 8 and two PICE x slots
- Drive Controller: Internal PERC H330 RAID with RAID 1 OS, 2x4 connectors, PCIe, 256 MB cache, expandable to eight drives,
- Hard Drives: 500 GB (2 x 250 GB), 7.2k RPM SATA, 6 Gbps 3.5 inch, Hotplug,
- CD-ROM: DVD +/-RW SATA Drive, internal,
- Video Card: Integrated video chipset controller 8 MB SD RAM including 3D 60 MHz memory, 480 MB/s memory bandwidth and DirectX 5.0,
- Video Adaptor: SGVA,
- Mounting: Slide ready rails and cable management
- Network: Quad-port Gigabit Network Adaptor with TOE, two x PCIe v 2.0, ACPI v 2.0, SMBus 2.0,
- Embedded Controller: Out of band management, iDRAC8 Express, integrated remote access controller, and
- Operating System: Microsoft Server 2008, Standard Edition and 5 CALs.

3. Physical Features

Provide rack-mounted ITS servers for proposed enclosed 19-inch communications rack located in the TMC. Provide servers with a maximum size of 2 RUs.

Provide servers meeting the minimum following power requirements:

- Power supply: 110-130 VAC.
- Power consumption: Typical 750W per power supply.

Provide servers meeting the following data port requirements:

- Serial: One standard serial port,
- Audio: Three jacks – channel out, line in, and microphone.
- Ethernet: Dual 1000 Base T Ethernet with RJ-45 connectors as described above and
- USB port: Four USB 2.0 ports.

◆ **Revision No. 1, April 10, 2017 - This document supersedes version originally issued and sealed by J. Todd Brooks, NCPE No. 017586 on 12/28/2016**

U-4715B**ITS-275****Buncombe County**

Provide servers with at least one direct 10/100 Base T Ethernet LAN interface. The network connector shall be RJ-45 for Category 6 STP for interfacing with the signal system's Gigabit Ethernet core switch.

B. Computer Workstations

1. Functional

Provide computer workstations that can operate the signal system software and the video control software over an Ethernet network in the TMC and the City Transportation Department.

2. Performance

Provide computer workstations meeting the following requirements:

- Processor: Quad core Intel Xeon E5-1603 v23 processor at 2.8 GHz or greater, 10 MB cache, L2 cache at 1333 MHz,
- Memory: 8 GB DDR3 ECC at 1866 MHz,
- Network: 10/100/1000 Base T Ethernet PCI Express with RJ-45 connector,
- Hard Drive Controller: AHCI chipset SATA, non-RAID, six ports (6 -6 Gbps SW RAID),
- Hard Drive: CI 500 GB SATA, operating at 7200 RPM
- CD-ROM: 16X DVD and 16x DVD+/- RW,
- Keyboard: USB 104-key model,
- Mouse: USB 3-button optical mouse with center scroll,
- Sound: 16-bit integrated high definition audio with external speakers,
- Speakers: Sound bar for use with flat panel monitor,
- Video Card: Two (2) Dual 512 GB DDR3 memory, 64-bit, 14 Gbps, PCIe 2.1 compliant with dual DVI video outputs, maximum digital resolution 2560 x 1600, maximum analog resolution 1920 x 1200, with display port to DVI breakout cables for dual displays,
- Video Output: RGB and DVI connector,
- Desktop Monitor Color: 16.7 million colors,
- Operating System: Windows® 10 Professional, 64-bit, latest version,
- Application software: Enterprise version of Norton antivirus software compatible with City requirements, and DVD burning software, and
- Desktop Monitors: LED, dual 24-inch, digital flat panel display, DVI-D, HDCP Display ports,
 - USB Ports: USB 3.0, one upstream port and three downstream ports,
 - Resolution: 1,920 x 1,080 dpi,
 - Pixel Pitch: 0.275 mm
 - Viewing Angle: 178 degrees vertically and horizontally
 - Contrast Ratio: 1,000:1 (typical) and 10,000:1 (dynamic)
 - Brightness: 250 cd/m²
 - Colors: 16.7 million colors.

◆ **Revision No. 1, April 10, 2017 - This document supersedes version originally issued and sealed by J. Todd Brooks, NCPE No. 017586 on 12/28/2016**

3. Physical Features

Provide computer workstations meeting the minimum power requirements:

- Input voltage: 90-135 V at 50/60 Hz, and
- Output wattage: 825 W.

Provide computer workstations meeting the minimum port requirements:

- Keyboard: One USB connection,
- Mouse: One USB connection,
- Audio: Miniature phono jacks – line out, line in, and microphone,
- Ethernet: 10/100 Base T Ethernet with RJ-45 connector, and
- USB Port: At least 4 rear and 2 front USB 2.0 ports (min. 6 total)

Equip all computer workstations with at least one direct 10/100 Base T Ethernet LAN interface. The network connector shall be RJ-45 for Category 6 STP or 6 UTP for interfacing with the Ethernet core switch.

C. Laptop Computers

1. Functional

Provide laptop computers that can operate the signal system software and the video control software over an Ethernet network in the TMC, the City Transportation Department, in a field cabinet and remotely.

2. Performance

Ensure that the laptop computers meet the following requirements. Ensure that the laptops have the capability to be networked with ITS LAN via an Ethernet cable connection through the Gigabit Ethernet core switch located in the TMC and over the Internet. Configure the laptop computers for connection anywhere in the network to facilitate maintenance and troubleshooting activities.

- Processor: Intel quad core i7-6820HQ at 2.74 GHz or greater, 3.60 GHz Turbo mode, 3M L2 cache at 1066 MHz,
- Memory: 4 GB DDR2-800 SDRAM, 2133MHz DDR4 SDRAM, Non-ECC
- Network: Integrated 10/100/1000 Base T Ethernet with RJ-45 connector, 802.11g wireless LAN card,
- WiFi Adaptor: Dual-band, 802.11 a/g/n 2X2 mini card with Bluetooth 4.1
- Hard Drive Controller: C1, All SATA drives, non-RAID,
- Hard Drive: 250 GB SATA operating at 7200 RPM,
- CD-ROM: 8X DVD+/-RW combo drive,
- Keyboard: 104 key model,
- Mouse: USB, 2 three-button optical mice,
- Audio: Miniature phono jacks – line out, line in, and microphone
- Sound: Integrated audio with internal speakers,
- Video Adaptor: 2 GB GDDR5 memory, 128-bit, 72 Gbps memory bandwidth, VGA, HDMI and display port support, 1920 x 1200, 32-bit,

U-4715B**ITS-277****Buncombe County**

- Internal Monitor: 16.5-inch HD, LED, 1366 x 768,
- Operating System: Windows® 7 Professional, latest version,
- Application software: Enterprise version of Norton antivirus software compatible with Department requirements, and DVD burning software, and
- Other Accessories: Two AC adaptors per laptop, spare battery and nylon travel bag.

3. Physical Features

Ensure that the laptop computer operates on an input voltage of 90 to 135 VAC at 50/60 Hz. Provide laptop computers meeting the following minimum port requirements:

- Audio: Three jacks – channel out, line in, and microphone,
- Ethernet: 10/100 Base T Ethernet with RJ-45 connector, and
- USB Port: Two USB 2.0 ports.
- Monitor: LED, anti-glare screen (for outdoor use in sunlight)

Equip the laptop computer with at least one direct 10/100 Base T Ethernet LAN interface. Ensure that the network connector is an RJ-45 for Category 6 STP to interface with the Ethernet core switch.

D. Printer

Provide a color laser network printer meeting the following requirements:

- Memory: Minimum of 192 MB of RAM,
- Communications: Ethernet 10/100 Base-T network card with RJ-45 connector, bi-directional IEEE 1284 ECP-compliant parallel interface, and one (1) open EIO expansion slot,
- Typefaces: Latest version of Windows print typefaces,
- Resolution: 600x 600 dpi (color or black and white),
- Printer Language: PCL 6 with commands for fully integrated HP-GL/2 vector graphics and advanced imagery/special effects printing with a minimum of 80 internal and scaleable fonts,
- Printer Speed: 20 pages per minute (ppm) for both color and black and white prints,
- First Page Out Time: 16 seconds,
- Cartridges: Black, three colors,
- Paper Tray Capacity: 100 sheet capacity,
- Paper Tray Output: 250-sheet tray,
- Tray Sizes: 8.5 x 11 inch, 8.5 x 14 inch, and 11 x 17 inch.

U-4715B**ITS-278****Buncombe County****E. KVM Switch****1. Functional**

Provide keyboard-video-mouse (KVM) assembly that can access and provide operator interface for at least 10 servers. The KVM switch may have either an integral tilt-up screen or a separate screen.

2. Performance

Provide KVM meeting the following requirements:

- Meets EIA-310C & IEC-3 specifications,
- The KVM assembly shall include KVM switch, keyboard, flat screen display, and associated cabling,
- Port selection by pushbuttons, on-screen display, or hot keys,
- Remotely accessible over the network,
- Active port status LEDs,
- Administrative and user assignable rights,
- IP addressable,
- Compatible with Windows® 7 Professional and Windows® Server 2008,
- Support video resolution up to 1,600 x 1,200 at 75 Hz, and
- Servers: Minimum of six.

3. Physical Features

Furnish a KVM switch meeting the following material requirements:

- Monitor: Integrated or separate 17-inch, TFT 1,280 x 1,024, 27 dpi, SGVA, LED, folding rack-mounted, contrast ratio of 350:1, frame rate of 60Hz (typ.), 75Hz (Max),
- Keyboard: 104 key model,
- Mouse: Touch pad,
- KVM switch: Rack-mounted, maximum 2 RU size,
- Cabling: All power, keyboard, mouse and display cabling between each server and the KVM assembly; and mounting brackets, and
- Power Supply: 120 VAC.

F. UPS**1. Functional**

Provide UPS units that produce uninterruptible power and power conditioning for the computer workstations in the City Transportation Department as well as the computer workstations in the TMC.

Each UPS shall provide adequate capacity to run its respective workstation and monitor(s) without commercial power for twenty minutes. Provide load calculations for each configuration of equipment connecting to a UPS.

U-4715B**ITS-279****Buncombe County****2. Performance**

Provide UPS meeting the following performance requirements:

- Output voltage distortion: less than 5 percent,
- Nominal input voltage: 120V,
- Nominal output voltage: 120V,
- Input frequency: 50/60 Hz \pm 3Hz, auto-sensing,
- Output frequency (sync to mains): 57-63 Hz for 60 Hz nominal frequency,
- Waveform type: Sine wave, and
- Noise filtering: Full time multi-pole noise filtering shall meet 0.3% IEEE surge let-through; zero clamping response time shall meet UL 1449.

Verify that the UPS meets all specifications and is capable of performing all of its functions during and after being subjected to:

- Operating temperature: 0-104° F,
- Operating relative humidity: 95%,
- Storage temperature: 5-113° F, and
- Storage relative humidity: 95%.

3. Physical Features

Supply each UPS unit with twenty-five (25) percent spare outlets. Ensure that the UPS meets the following material requirements:

- Floor mounted for all workstations and laptops at all locations
- Sealed AGM type, maintenance free batteries,
- USB interface port,
- Status Lights: power on, power source and overload,
- Alarms: audible and remote notification, and
- Manual power on/off switch.

Supply UPS unit with multi-pole noise filtering. Ensure that the UPS remote monitoring software performs the following functions:

- Data logging,
- Event logging,
- Fault notification,
- Unattended system shutdown,
- Hibernation,
- Operating system shutdown, and
- Power event summary.

G. Ethernet Patch Panel

Furnish a rack-mountable 48-port Ethernet patch panel for installation in the enclosed 19-inch communications rack inside the TMC. Provide patch panels designed for Category 6 cable and that meets TIA/EIA-568-C.1 Category 6 and ISO 11801 Class D standards. All ports shall be RJ-45 eight-wire jacks. Provide all mounting screws and mounting hardware needed to mount the patch panel in a 19-inch equipment rack.

◆ **Revision No. 1, April 10, 2017 - This document supersedes version originally issued and sealed by J. Todd Brooks, NCPE No. 017586 on 12/28/2016**

U-4715B

ITS-280

Buncombe County

38.3. CONSTRUCTION REQUIREMENTS

A. General

Receive approval for the System Design Report described in these Project Special Provisions before submitting products submittal data, purchasing, installing and configuring the computer and communications hardware at each facility. Implement the plan upon approval.

Integrate all servers, workstations, laptops, and printers on the ITS LAN so all applications will be fully functional. Install the operating system, software and antivirus software to NCDOT Information Technology (IT) standards.

Furnish all tools, equipment, materials, supplies, and manufactured hardware, and perform all operations and equipment integration necessary to provide a complete, fully operational network. Mount all TMC server equipment as shown in the Plans in enclosed 19" communications racks.

All cabling shall be:

- Neatly tagged with permanent labels at both ends of every cable,
- Secured with wire ties and cable management hardware in the communications racks, and
- Grounded to rack grounding hardware.

Ensure that all project IP addresses are assigned as defined in the System Design Report. Ensure the as-built documentation includes the identification of all IP addresses and VLANs, and associated hardware devices and device locations.

B. ITS Servers

Install the TMC ITS servers in the proposed enclosed 19-inch communications racks located in the TMC as shown in the Plans. Install the software packages described in these Project Special Provisions.

Install all software necessary to support the signal system software and to meet all of the data communications requirements described in these Project Special Provisions, including once-per-second polling of all traffic signal controllers.

Connect proposed ITS servers to the respective Ethernet switches. Install Ethernet patch cords between the Ethernet patch panel and the managed Ethernet switch in the TMC. Plug power supplies into outlets on separate circuits. Connect servers to KVM switch. Power up and run diagnostics.

Configure the ITS LAN for remote access through the firewall with remote access software for up to four laptop licenses.

C. Computer Workstation

Install the computer workstations in locations as shown in the Plans. Install the client software packages described in these Project Special Provisions.

U-4715B**ITS-281****Buncombe County**

Connect the workstations to the ITS LAN by installing Ethernet patch cords between the Ethernet patch panel and the Ethernet core switch in the TMC. Perform the following operational tests for each computer component in accordance with the test plans. After the equipment has been installed, perform the following:

- Connect all components (monitors, mice, keyboards, existing printers, network cables, power supplies),
- Install all software required in these Project Special Provisions,
- Configure network communications,
- Map network drives and existing printers,
- Run diagnostic utilities on the hardware, and
- Print test pages for each workstation on each existing printer to verify printer configuration.

D. Laptop Computers

Install the laptop computers with supporting hardware in the TMC and at the City Transportation Department. Connect the laptops to the ITS LAN through the respective Ethernet switches in those facilities.

Perform the following operational tests for each computer component in accordance with the test plans. After the equipment has been installed, perform the following:

- Connect all components (monitors, mice, keyboards, existing printers, network cables, power supplies),
- Install all software required in these Project Special Provisions,
- Configure network communications,
- Map network drives and existing printers,
- Run diagnostic utilities on the hardware, and
- Print test pages for each laptop on the existing printers to verify printer configuration.

E. Printer

Install the color network printer in the TMC as directed by the Engineer. Connect the printer to the ITS LAN. Setup laptops and workstations on the network to use the printer and print a test page from each printer and laptop.

F. KVM Switch

Install the KVM assembly in the enclosed 19-inch communications rack with the ITS servers in the TMC. After the KVM assembly has been installed, perform the following operational tests on the KVM assembly in accordance with the test plans:

- Connect all existing and proposed servers, monitors, keyboards, mice, and power supplies,
- Program the on-screen display to assign ports and bank numbers and to enter the names of each server in the menu,
- Program the KVM switch for scan features and access privileges, and
- Select each server and ensure the mouse and keyboard work the selected server and the monitor displays the appropriate server.

◆ **Revision No. 1, April 10, 2017 - This document supersedes version originally issued and sealed by J. Todd Brooks, NCPE No. 017586 on 12/28/2016**

U-4715B

ITS-282

Buncombe County

G. UPS

Install UPS units in the TMC and in the City Transportation Department as close as possible to their respective equipment. Connect the UPS unit to a power outlet. Connect the UPS monitoring port to a USB port on its respective workstation.

Install the UPS monitoring software on the workstations in the TMC and City Transportation Department for remote monitoring of the respective UPS units. Configure the remote monitoring to send email alerts. Run the UPS diagnostics.

H. Ethernet Patch Panel

Mount the 48-port Ethernet patch panel in the enclosed communications rack inside the TMC as shown in the Plans. Terminate the Ethernet cables from the respective racks on the punch down block. Follow manufacturer's installation instructions for cable termination and panel assembly. Install Ethernet patch cables between the patch panel and the respective Ethernet switches.

I. Existing Equipment

Reuse the existing printers in the TMC. Remove all existing servers, computers, monitors, and associated support equipment designated to be removed in the Plans and these Project Special Provisions. Deliver all servers, workstations and flat screen monitors to the Department. Dispose of all other equipment.

38.4. DOCUMENTATION

Furnish the Department and the City two copies of the following materials prior to acceptance: installation, operation, training and troubleshooting manuals, wiring diagrams, including cable pinouts, parts lists, warranty materials, and serial and model numbers of all equipment furnished. Furnish all software and operating system on CD or DVD with original license information registered to the City of Asheville.

38.5. WARRANTY

Provide a minimum of three-year manufacturer's warranty to guarantee the materials supplied are free of defects and workmanship. The manufacturer's warranty period starts upon the date of final acceptance.

38.6. MEASUREMENT AND PAYMENT

ITS server will be measured and paid as the actual number of ITS servers furnished, installed, and accepted.

Computer workstation will be measured and paid as the actual number of computer workstations with monitor(s), keyboard, UPS, mouse, operating system, and software furnished, installed, and accepted.

Laptop computer will be measured and paid as the actual number of laptop computers with external monitors, keyboard, mouse, AC adaptors, spare battery, nylon travel bag, operating system, and software furnished, installed, and accepted.

Printer will be measured and paid as the actual number of printers with AC adaptor and software furnished, installed, and accepted.

◆ **Revision No. 1, April 10, 2017 - This document supersedes version originally issued and sealed by J. Todd Brooks, NCPE No. 017586 on 12/28/2016**

U-4715B**ITS-283****Buncombe County**

KVM switch will be measured and paid as the actual number of KVM switches furnished, installed, and accepted. If a separate LED monitor is provided, then no separate measurement and payment will be made for the monitor.

No separate measurement will be made for coaxial cables, communication cables, electrical cables, mounting hardware, nuts, bolts, brackets, connectors, risers, grounding equipment, or surge suppression, as these will be considered incidental to the pay items for installing ITS server, laptop and workstation computer, and KVM switch.

No separate measurement will be made for the Ethernet patch panels as these will be considered incidental to the pay item for Ethernet cable. Ethernet cable will be measured and paid in accordance with the "Ethernet Cable" section of these Project Special Provisions.

No separate measurement will be made for UPS units supplied with each workstation. The UPS units for workstation computers will be considered incidental to the pay items for workstation and laptop computers.

No measurement and payment will be made for removal of existing computer hardware and peripherals and existing communications hardware in the TMC and the City Transportation Department as such work will be considered incidental to furnishing and installing computer hardware and peripherals and communications hardware at those locations.

Payment will be made under:

| Pay Item | Pay Unit |
|----------------------|-----------------|
| ITS Server | Each |
| Computer Workstation | Each |
| Laptop Computer | Each |
| Printer | Each |
| KVM Switch | Each |

◆ **Revision No. 1, April 10, 2017 - This document supersedes version originally issued and sealed by J. Todd Brooks, NCPE No. 017586 on 12/28/2016**

39. COMMUNICATIONS HARDWARE

39.1. DESCRIPTION

Furnish and install all equipment described below for a fully functional Gigabit Ethernet network for communication to the signal system and CCTV.

A. Ethernet Core Switch

Furnish and install a central Layer 3 managed Gigabit Ethernet core switch along with a Category 6 patch panel for the TMC. Ensure that the managed Ethernet core switch provides Gigabit Ethernet connectivity at transmission rates of 1000 megabits per second (Mbps), and is expandable to 10 Gigabits per second (Gbps).

B. Ethernet Edge Switch

Furnish and install a hardened, field Ethernet edge switch (hereafter “edge switch”) for field devices. Ensure that the edge switch provides wire-speed, Ethernet connectivity at each ITS device location to the Ethernet core switch.

C. Firewall

Furnish and install firewall appliances in the TMC to provide network security from Internet-based traffic, as well as to provide an IPsec Virtual Private Network (VPN) connectivity.

D. Network Management Software

For the communications network, utilize network management software (NMS) for configuration, troubleshooting, security, and system monitoring. The software shall be furnished and installed by the Contractor ♦ to manage and monitor the Ethernet core ♦ and Ethernet edge switches ♦ and the ITS devices. ♦ The Contractor shall perform the initial system integration of all core and edge switches installed on the project.

Install the network management software on all relevant communications hardware, including workstations, laptops and servers, as recommended by the manufacturer’s instructions. Ensure that the network management software is compatible with all elements of the network, including the Ethernet switches, workstations, laptops, and servers. Ensure the system meets the minimum technical requirements and is capable of handling expansion within the ITS network. Ensure that the software manages third party switches and hardware via Simple Network Management Protocol (SNMP) v1 or v3.

Provide system that has a graphical user interface (GUI) for the operator and shall graphically depict the equipment and maintenance/operational status using a graphical map of the system. Include setup and diagnostic utility software for both the server and client computers (licenses to be provided by the Contractor). Ensure that the system is interoperable with all end-to-end communications elements (video encoder, Ethernet switches, and video decoder) that connect each CCTV camera to analog and digital video monitors.

E. Uninterruptible Power Supply (UPS)

Furnish and install a new rack-mounted UPS in the TMC to serve the Ethernet core switch, ITS servers and other equipment mounted in the communications racks in the server room.

♦ **Revision No. 1, April 10, 2017 - This document supersedes version originally issued and sealed by J. Todd Brooks, NCPE No. 017586 on 12/28/2016**

U-4715B**ITS-285****Buncombe County**

Each UPS shall also include any ancillary equipment or incidental items, such as required mounting hardware and cabling. Furnish and install monitoring software to provide email alerts.

Furnish all materials with the most recently developed and approved product versions that meet or exceed all applicable standards, specifications, and requirements before the system is considered for acceptance. Size the UPS to provide at least 20 minutes of UPS power. Provide the UPS a 25% reserve of receptacles. Provide load calculations for each configuration of equipment connecting to a UPS.

39.2. MATERIALS

A. General

Ensure that the Ethernet switches are fully compatible and interoperable with the trunk Ethernet network interface and that the Ethernet switches support half and full duplex Ethernet communications.

Furnish Ethernet switches that provide 99.999% error-free operation, and that comply with the Electronic Industries Alliance (EIA) Ethernet data communication requirements using single-mode fiber-optic transmission medium and copper transmission medium. Ensure that the Ethernet switches have a minimum mean time between failures (MTBF) of 10 years, or 87,600 hours, as calculated using the Bellcore/Telcordia SR-332 standard for reliability prediction.

Provide all SMFO jumpers required to connect the Ethernet core switch and Ethernet edge switches with the connector panels of fiber-optic splice centers. Provide SMFO jumpers with factory-assembled LC connectors on one end (i.e., the fiber-optic interconnect center/connector housing end) and, on the other end, factory-assembled connectors of the same type provided on the managed Ethernet core switch and Ethernet edge switch.

Provide SMFO jumpers that are a minimum of 3 feet in length for Ethernet switches inside controller cabinets, CCTV cabinets, the TMC and the City Transportation Department. Furnish SMFO jumpers that are a minimum of 6 feet in length for the communications racks inside the TMC. Ensure SMFO jumpers meet the operating characteristics of the SMFO cable with which it is to be coupled.

B. Ethernet Core Switch

1. Standards

Provide an Ethernet core switch that complies with the following IEEE networking standards for Ethernet communications:

- IEEE 802.1D Spanning Tree Protocol (STP),
- IEEE 802.1P Quality of Service (QoS),
- IEEE 802.1Q Virtual Local Area Networks (VLAN Tagging),
- IEEE 802.1S Multiple Spanning Tree Protocol (MSTP),
- IEEE 802.1X Port-Based Network Access Control,
- IEEE 802.1W Rapid Spanning Tree Protocol (RSTP),
- IEEE 802.3X Flow Control,
- IEEE 802.3Z Standards Compliant 1000 Base-SX and 1000 Base-LX optics,
- IEEE 802.3ad Link Aggregation,
- RFC 821 – Simple Mail Transfer Protocol (SMTP),

◆ **Revision No. 1, April 10, 2017 - This document supersedes version originally issued and sealed by J. Todd Brooks, NCPE No. 017586 on 12/28/2016**

- RFC 854 – Telnet Protocol Specification,
- RFC 1112 – IGMP v1,
- RFC 2131 – Dynamic Host Configuration Protocol for IPv4,
- RFC 2236 – IGMP v2,
- RFC 3315 – Dynamic Host Configuration Protocol for IPv6 (DHCPv6),
- RFC 3376 – IGMP v3,
- RFC 2362 – Protocol Independent Multicast Sparse Mode (PIM-SM),
- RFC 3973 – Protocol Independent Multicast Dense Mode (PIM-DM),
- RFC 2328 – Open Shortest Path First (OSPF) v2,
- RFC 2338 – Virtual Router Redundancy Protocol (VRRP),
- RFC 2570:2575 – SNMP v3,
- RFC 2030 – Simple Network Time Protocol (SNTP), and
- RFC 2267 – Denial of Service (DoS).

Ensure that the Ethernet core switch has a minimum mean time between failures (MTBF) of 10 years, or 87,600 hours, as calculated using the Bellcore/Telcordia SR-332 standard for reliability prediction.

Ensure that the Ethernet core switch has a limited lifetime hardware warranty.

2. Functional

Provide an Ethernet core switch that is comprised of multiple stackable switches that form a single virtual chassis. The virtual chassis shall be managed as a single network device. The Ethernet core switch shall have a minimum of **four (4)** switches in the initial virtual chassis, however additional switches may be required to meet the port requirements indicated in the Plans. The Ethernet core switch shall have a minimum of two dedicated virtual chassis (stacking) ports providing a minimum 128 Gbps switching capacity across the virtual backplane. Ensure the Ethernet core switch complies with the EIA's Ethernet data communication requirements using a single-mode fiber-optic transmission media; and Category 6 copper transmission media.

Provide a stackable-type design with the capability to expand the stack to a minimum of eight (8) units in a single logical device (virtual chassis) that meets the following minimum requirements:

Power:

- Redundant power supplies, either on a per-switch basis or as a shared resource for each switch in the stack,
- Hot swappable while running without opening the chassis without interrupting the operation,
- Autosensing and autoswitching, and
- 110 VAC single phase power source.

I/O:

- A minimum of four (4) switches shall be provided in a full stacking configuration with additional switches provided as needed to meet the required number of optical and copper ports indicated in the plans.

U-4715B

ITS-287

Buncombe County

- Each virtual chassis shall contain:
 - A minimum of twenty-four (24) ports per switch,
 - A minimum of three (3) switches with a total of sixty (60) fiber-optic 100/1000 Base-X optical ports at full wire speed.
 - One switch with twenty-four (24) 10/100/1000 Base-T ports at full wire speed.
- Ethernet single mode fiber-optic ports shall support Standard (10 km) and Long Haul (70+ km) optics.

High Availability (HA) Features:

- Redundant, hot swappable power supplies
- Ability for each switch in the stack to serve as the master (1:N availability)
- Cross module link aggregation

Security Features:

- IEEE 802.1X – RADIUS Authentication,
- TACACS+,
- Secure Shell (SSH v2),
- Access Control List (ACL), and
- Denial of Service (DoS) Protection.

Optical Ports: Ensure that all single mode fiber-optic link ports operate at 1310 or 1550 nanometers. Provide fully-functional ports with Type LC connectors and the optics for the optical ports as specified in the Plans or by the Engineer. Do not use mechanical transfer registered jack (MTRJ) or ST type connectors. At a minimum, the core Ethernet switch shall be equipped with sixty (60) fully functional single mode 1 Gbps fiber-optic SFP transceivers, but additional SFPs may be required to meet the total port requirements in the Plans. Provide small form-factor plug-able (SFP) optics with 10 km, 20 km, 40km, 70 km, or 120 km optics as required to meet the distance requirement as indicated in the Plans.

Provide 1 Gbps optical transceivers as specified in the Plans or by the Engineer. Each transceiver consists of fiber pairs; one fiber will transmit (TX) data and one fiber will receive (RX) data. Provide optical transceivers that meet the following minimum requirements:

- Optical receiver sensitivity: -20 dBm,
- Optical transmitter power: 9.5 to -3 dBm,
- Estimated transmission distance: 20 km,
- Operating wavelength: 1310 nm, and
- Operating temperature: -40 to 185 degrees F.

Copper Ports: Provide 48 fully functional copper ports installed in the Ethernet core switch virtual chassis. Provide copper ports that are Type RJ-45 and that auto-negotiate speed (i.e., 10/100/1000 Base) and duplex (i.e., full or half). Ensure that all 10/100/1000 Base TX ports meet the specifications detailed in this section and are compliant with the IEEE 802.3 standard pinouts. Ensure that all Category 6 shielded twisted pair/shielded twisted pair network cables are compliant with the EIA/TIA-568-A standard.

◆ **Revision No. 1, April 10, 2017 - This document supersedes version originally issued and sealed by J. Todd Brooks, NCPE No. 017586 on 12/28/2016**

Ensure that the Ethernet core switch (10/100/1000 Mbps ports) supports jumbo frames and full Layer 3 routing. Ensure that the switch includes support for dynamic unicast routing protocols such as RIPv1/v2 and OSPF, and support for multicast routing protocols, including PIM-SM, PIM-DM, and DVMRP.

Port Security: Supply an Ethernet core switch that supports/complies with the following (remotely) minimum requirements:

- Ability to configure static MAC addresses,
- Ability to disable automatic address learning per port, known hereafter as Secure Port. Secure Ports only forward data for pre-defined / learned MAC addresses, and
- Trap and alarm upon any unauthorized MAC address and shutdown for programmable duration. Port shutdown requires administrator to manually reset the port before communications are allowed.

3. Physical Features

Physical: Provide an Ethernet core switch that is rack mountable into a standard 19-inch EIA rack and not exceed 10 RU in height. Provide all mounting kits, brackets, and hardware for mounting into a standard 19-inch rack.

Chassis Fan Assembly: Equip the managed Ethernet core switch with at least one cooling fan assembly per power supply to cool the CPU, main memory, and voltage regulators. Ensure that the fan has sufficient capacity and airflow to cool the switch.

4. Electrical Specifications

Ensure that the Ethernet core switch operates and power is supplied with 115 volts of alternating current (VAC) at 60 Hz input frequency. Ensure that the Ethernet core switch has a minimum operating input of 110 VAC and a maximum operating input of 130 VAC. Ensure that if the device requires operating voltages other than 120 VAC, supply the required voltage converter. Ensure that the maximum power consumption does not exceed 350 watts per switch for the Ethernet core switch. Ensure that the managed Ethernet core switch and GBICs have diagnostic light emitting diodes (LEDs), including link, TX, RX, speed (for Category 6 ports only), and power LEDs.

5. Performance Requirements

Ensure that the Ethernet core switch includes management capabilities, as defined in the following:

- Have a non-blocking architecture,
- Route and switch unicast and multicast traffic simultaneously at wire speed,
- Support fully redundant load sharing and hot swappable power supplies (N+1 support),
- Minimum 88 Gbps switching capacity per switch
- Minimum throughput: 65 Mbps per switch
- Minimum 128 Gbps switching capacity via stacking port
- Minimum 10k unicast routes in hardware
- Minimum 2k multicast routes in hardware

6. Management Capabilities

Ensure that the Ethernet core switch includes management capabilities, as defined in the following:

- Incorporate an internal temperature sensor capable of sending system log and/or SNMP traps should the switch exceed a specified warning level,
- Support automatic powering off should the temperature exceed a specified level to prevent damage to the switch,
- Support port mirroring and monitoring to aid in troubleshooting,
- Be capable of utilizing the following standard protocols:
 - Support VLAN (IEEE 802.1Q),
 - Support Multiple Spanning Tree Protocol (IEEE 802.1Q-2005),
 - Support Rapid Spanning Tree Protocol (IEEE 802.1W),
 - Support IGMP Versions 1 and 2 (RFC 1112 and 2236),
 - Support RIP Versions 1 and 2 (RFC 1058 and 1723),
 - Support OSPF Version 2 (RFC 1583 and 2328),
 - Support PIM (SM & DM),
 - Support IGMP Version 1 and 2 (RFC 1112 and 2236),
 - Support DVMRP,
 - Support VRRP (RFC 2338),
 - Support ToS/DSCP mapping to priority queue,
 - Support QoS queue management using weighted round robin (WRR) and strict priority (SP),
 - Support 10/100/1000 BaseTX ports (RJ-45),
 - Support a minimum of (2) 10-Gigabit Ethernet ports per switch,
 - Support Flow Control (IEEE 802.3x),
 - Support Gigabit Ethernet (IEEE 802.3z),
 - Support SNMP Version 1 and 3,
 - Support 4 groups of RMON-I (Groups 1-3, 9),
 - Be managed through console (RS-232), telnet, and Web interface, and
 - Support download and upload of images and configurations via Trivial File Transfer Protocol (TFTP).

Ensure that the Ethernet core switch fully supports all Layer 2 and Layer 3 management features related to multicast data transmission and routing, including, but not be limited to:

- An STP healing/convergence rate that meets or exceeds specifications published in the IEEE 802.1 D standards.
- An RSTP healing/convergence rate that meets or exceeds specifications published in the IEEE 802.1w standard.
- A core switch that is a port-based VLAN and supports VLAN tagging that meets or exceeds specifications as published in the IEEE 802.1Q standard.
- A forwarding/filtering rate that is a minimum of 14,880 packets per second for 10 megabits per second and 148,800 packets per second for 100 megabits per second.
- Support of Traffic Class Expediting and Dynamic Multicast Filtering.

- Support of, at a minimum, Version 2 of the Internet Group Management Protocol (IGMP).
- Support of remote and local setup and management via telnet, Secure Shell (SSHv2) or secure Web-based GUI and command line interfaces.
- Support of the SNMP protocol.
- Verify that the Ethernet core switch can be accessed using the resident EIA-232 management port, a telecommunication network, or the TFTP.
- Port security through controlling access by the users. Ensure that the Ethernet core switch has the capability to generate an alarm and shut down ports when an unauthorized user accesses the network.
- Support of the TFTP and the SNTP. Ensure that the Ethernet core switch supports port mirroring for troubleshooting purposes when combined with a network analyzer.

7. Environmental Specifications

Supply an Ethernet core switch that adheres to the following environmental constraints:

- Operating Temperature Range: 32° F to 104° F,
- Storage Temperature Range: 14° F to 158° F, and
- Operating Relative Humidity Range: 10% to 95%, noncondensing.

C. Ethernet Edge Switch

1. Standards

Ensure that the Ethernet edge switches comply with all applicable IEEE networking standards for Ethernet communications, including but not limited to:

- IEEE 802.1D standard for media access control (MAC) bridges used with the Spanning Tree Protocol (STP),
- IEEE 802.1P standard for Quality of Service (QoS),
- IEEE 802.1Q standard for port-based virtual local area networks (VLANs),
- IEEE 802.1Q-2005 standard for MAC bridges used with the Multiple Spanning Tree Protocol,
- IEEE 802.1w standard for MAC bridges used with the Rapid Spanning Tree Protocol (RSTP),
- IEEE 802.1x standard for port based network access control, including RADIUS,
- IEEE 802.3 standard for local area network (LAN) and metropolitan area network (MAN) access and physical layer specifications,
- IEEE 802.3u supplement standard regarding 100 Base TX/100 Base FX,
- IEEE 802.3x standard regarding flow control with full duplex operation, and
- RFC 783 – TFTP
- RFC 854 – Telnet Protocol Specification,
- RFC 1112 – IGMP v1,
- RFC 1541 – Dynamic Host Configuration Protocol for IPv4,
- RFC 2030 – SNTP
- RFC 2068 – HTTP
- RFC 2236 – IGMP v2,
- RFC 2865 – RADIUS

◆ **Revision No. 1, April 10, 2017 - This document supersedes version originally issued and sealed by J. Todd Brooks, NCPE No. 017586 on 12/28/2016**

- RFC 3414 – SNMPv3-USM
- RFC 3415 – SNMPv3-VACM.

Ensure that the Ethernet edge switches have a minimum mean time between failures (MTBF) of 10 years, or 87,600 hours, as calculated using the Bellcore/Telcordia SR-332 standard for reliability prediction.

2. Functional

Ensure that the Ethernet edge switches support all Layer 2 management features and certain Layer 3 features related to multicast data transmission. These features shall include, but not be limited to:

- An STP healing/convergence rate that meets or exceeds specifications published in the IEEE 802.1D standard,
- An RSTP healing/convergence rate that meets or exceeds specifications published in the IEEE 802.1w standard,
- An Ethernet edge switch that is a port-based VLAN and supports VLAN tagging that meets or exceeds specifications as published in the IEEE 802.1Q standard, and has a minimum 4-kilobit VLAN address table (254 simultaneous),
- A forwarding/filtering rate that is a minimum of 14,880 packets per second for 10 megabits per second and 148,800 packets per second for 100 megabits per second,
- A minimum 4-kilobit MAC address table,
- Support of Traffic Class Expediting and Dynamic Multicast Filtering,
- Support of, at a minimum, snooping of Version 2 of the Internet Group Management Protocol (IGMP),
- Support of remote and local setup and management via telnet or secure Web-based GUI and command line interfaces,
- Support of the Simple Network Management Protocol version 3 (SNMPv3). Verify that the Ethernet edge switch can be accessed using the resident EIA-232 management port, a telecommunication network, or the Trivial File Transfer Protocol (TFTP),
- Port security through controlling access by the users. Ensure that the Ethernet edge switch has the capability to generate an alarm and shut down ports when an unauthorized user accesses the network,
- Support of the TFTP and SNTP. Ensure that the Ethernet edge switch supports port mirroring for troubleshooting purposes when combined with a network analyzer.

3. Physical Features

Mounting: Provide mounting kit to attach the Ethernet edge switch to a DIN rail in the cabinet. Supply the DIN rail with the Ethernet edge switch.

Ports: Provide 10/100 Mbps auto-negotiating ports (RJ-45) copper Ethernet ports for all Ethernet edge switches. Provide auto-negotiation circuitry that will automatically negotiate the highest possible data rate and duplex operation possible with attached devices supporting the IEEE 802.3 Clause 28 auto-negotiation standard.

Optical Ports: Ensure that all fiber-optic link ports operate at 1310 or 1550 nanometers in single mode. Provide fully-functional ports with Type LC connectors and the optics for the optical ports. Do not use mechanical transfer registered jack (MTRJ) or ST type connectors.

◆ **Revision No. 1, April 10, 2017 - This document supersedes version originally issued and sealed by J. Todd Brooks, NCPE No. 017586 on 12/28/2016**

U-4715B**ITS-292****Buncombe County**

Provide Ethernet edge switches having a minimum of two optical 100 Base FX ports capable of transmitting data at 100 megabits per second. Ensure that each optical port consists of a pair of fibers, one fiber will transmit (TX) data and one fiber will receive (RX) data.

Provide 10/100 Mbps optical ports that consist of fiber pairs, one fiber will transmit (TX) data and one fiber will receive (RX) data. Provide optical ports that meet the following minimum requirements:

- Optical receiver sensitivity: -32 dBm,
- Optical transmitter power: -15.5 dBm,
- Typical transmission distance: 20 km, and
- Operating wavelength: 1310 nm.

Copper Ports: Provide Ethernet edge switches that include a minimum of six copper ports. Provide Type RJ-45 copper ports and that auto-negotiate speed (i.e., 10/100 Base) and duplex (i.e., full or half). Ensure that all 10/100 Base TX ports meet the specifications detailed in this section and are compliant with the IEEE 802.3 standard pinouts. Ensure that all Category 6 shielded twisted pair network cables are compliant with the EIA/TIA-568-C.1 standard.

Port Security: Ensure that the Ethernet edge switches support/comply with the following (remotely) minimum requirements:

- Ability to configure static MAC addresses,
- Ability to disable automatic address learning per ports, known hereafter as Secure Port. Secure Ports only forward, and
- Trap and alarm upon any unauthorized MAC address and shutdown for programmable duration. Port shutdown requires administrator to manually reset the port before communications are allowed.

Network Capabilities: Provide Ethernet edge switches that support/comply with the following minimum requirements:

- Provide full implementation of IGMPv2 snooping (RFC 2236),
- Provide full implementation of SNMPv1, SNMPv2c, and/or SNMPv3,
- Capable of mirroring any port to any other port within the switch,
- Meet the IEEE 802.1Q (VLAN) standard per port for up to four VLANs,
- Meet the IEEE 802.3ad (Port Trunking) standard for a minimum of two groups of four ports,
- Telnet/CLI,
- HTTP (Embedded Web Server) with Secure Sockets Layer (SSL), and
- Full implementation of RFC 783 (TFTP) to allow remote firmware upgrades.

Network Security: Provide Ethernet edge switches that support/comply with the following (remotely) minimum network security requirements:

- Multi-level user passwords,
- RADIUS centralized password management (IEEE 802.1X),
- SNMPv3 encrypted authentication and access security,
- Port security through controlling access by the users: ensure that the Ethernet edge switch has the capability to generate an alarm and shut down ports when an unauthorized user accesses the network,

◆ **Revision No. 1, April 10, 2017 - This document supersedes version originally issued and sealed by J. Todd Brooks, NCPE No. 017586 on 12/28/2016**

U-4715B**ITS-293****Buncombe County**

- Support of remote monitoring (RMON) of the Ethernet agent, and
- Support of the TFTP and SNMP. Ensure that the Ethernet edge switch supports port mirroring for troubleshooting purposes when combined with a network analyzer.

4. Electrical Specifications

Ensure that the Ethernet edge switches operate and power is supplied with 115 current VAC. Ensure that the Ethernet edge switches have a minimum operating input of 110 VAC and a maximum operating input of 130 VAC. Ensure that if the device requires operating voltages other than 120 VAC, supply the required voltage converter. Ensure that the maximum power consumption does not exceed 50 watts. Ensure that the Ethernet edge switches have diagnostic light emitting diodes (LEDs), including link, TX, RX, speed (for Category 6 ports only), and power LEDs.

5. Environmental Specifications

Provide Ethernet edge switches that adhere to the following environmental constraints as defined in the environmental requirements section of the NEMA TS 2 standard if located within a climate-controlled environment:

- Operating temperature range: -30°F to 165°F,
- Storage temperature range: 14°F to 158°F, and
- Operating relative humidity range: 10% to 90%, non-condensing.

Verify that the Ethernet edge switch manufacturer certifies their device has successfully completed environmental testing as defined in the environmental requirements section of the NEMA TS 2 standard. Verify that vibration and shock resistance meet the requirements of Sections 2.1.9 and 2.1.10, respectively, of the NEMA TS 2 standard. Ensure that the Ethernet edge switch is protected from rain, dust, corrosive elements, and typical conditions found in a roadside environment.

The Ethernet edge switches shall meet or exceed the following environmental standards:

- IEEE 1613 (electric utility substations),
- IEC 6185003 (electric utility substations),
- IEEE 61800-3 (variable speed drive systems), and
- IEC 61000-6-2 (generic industrial).

D. Firewall

1. Standards

Ensure that the firewall appliances comply with all applicable IEEE networking standards for Ethernet communications, including but not limited to:

- RFC 854: Telnet Protocol Specification.
- RFC 4271: Border Gateway Protocol (BGP).
- RFC 2328: Open Shortest Path First (OSPF).
- RFC 2338: Virtual Router Redundancy Protocol (VRRP).
- RFC 2453: Routing Information Protocol (RIP) version 2.
- RFC 2362: Protocol Independent Multicast Sparse Mode (PIM-SM).
- RFC 2236: Internet Group Management Protocol (IGMP) version 2. and
- IEEE 802.1X: Port-Based Network Access Control.

◆ **Revision No. 1, April 10, 2017 - This document supersedes version originally issued and sealed by J. Todd Brooks, NCPE No. 017586 on 12/28/2016**

U-4715B**ITS-294****Buncombe County**

Ensure that the firewall appliances have a minimum mean time between failures (MTBF) of 10 years, or 87,600 hours, as calculated using the Bellcore/Telcordia SR-332 standard for reliability prediction.

2. Performance Requirements

Ensure that the firewall appliances meet the following minimum performance requirements:

- Firewall Throughput: 350+ Mbps.
- Advanced Encryption Standard (AES) VPN Throughput: 100 Mbps.
- 3DES Encryption VPN Throughput: 100 Mbps.
- Maximum Concurrent Sessions: 48,000.
- Virtual Routers: 6, and
- Security Zones: 40.

Provide sufficient memory to enable optional features such as Intrusion Prevention System (IPS), antivirus, and anti-spam with no additional hardware upgrades.

3. Functional Requirements

Ensure that the firewall appliances support the following features which shall include, but not be limited to:

- IPsec VPN Capabilities:
 - 500 Concurrent VPN Tunnels.
 - DES, 3DES, and AES.
 - MD-5 and SHA-1 Authentication.
 - Manual Key, Internet Key Exchange (IKE), IKEv2, and EAP Public Key Infrastructure (PKI) (X.509).
 - Remote Access VPN.
- Authentication:
 - Web-based Authentication.
 - RADIUS.
 - 802.1X.
 - RSA SecureID.
- Modes of Operation:
 - Layer 2 Mode.
 - Layer 3 Mode.
- Address Translation:
 - Network Address translation (NAT).
 - Port Address Translation (PAT).
 - Mapped IP (MIP) (L3 Mode).
 - Virtual IP (VIP) (L3 Mode).
- High Availability (HA):
 - Active/active – L3 mode.
 - Active/passive – Transparent & L3 mode.
 - Configuration Synchronization.
 - VRRP.

◆ **Revision No. 1, April 10, 2017 - This document supersedes version originally issued and sealed by J. Todd Brooks, NCPE No. 017586 on 12/28/2016**

- Quality of Service / Traffic Management:
 - Guaranteed Bandwidth.
 - Maximum Bandwidth.
 - Priority Bandwidth Utilization.
- Support for optional Intrusion Prevention System (IPS) (Deep Inspection) subscription.
- Support for optional Antivirus, antispam, and web filtering subscription.
- Network Attack Detection.
- DoS and DDos Protection.
- TCP Reassembly for Fragmented Packet Protection.
- Brute Force Attack Mitigation.
- SYN Cookie Protection.
- Zone-based IP Spoofing, and
- Malformed Packet Protection.

4. Physical Features

Copper Ports: Provide a firewall appliance that includes a minimum of six (6) Ethernet 10/100 Base-T copper ports and two (2) Ethernet 10/100/1000 Base-T copper ports. Provide Type RJ-45 copper ports that auto-negotiate speed (i.e., 10/100/1000 Base) and duplex (i.e., full or half). Ensure that all ports meet the specifications detailed in this section and are compliant with the IEEE 802.3 standard pinouts. Ensure that all Category 6 shielded twisted pair network cables are compliant with the EIA/TIA-568-C.1 standard. Provide auto-negotiation circuitry that will automatically negotiate the highest possible data rate and duplex operation possible with attached devices supporting the IEEE 802.3 Clause 28 auto-negotiation standard.

5. Electrical Specifications

Ensure the firewall appliance meets the following electrical requirements:

- Input voltage range: 110 VAC to 130 VAC, auto ranging, and
- Input frequency: 60 Hz.

Ensure that if the firewall appliances require operating voltages other than 120 VAC, supply the required voltage converter. Ensure that the maximum power consumption does not exceed 200 watts.

6. Management Capabilities

Ensure that the firewall appliance supports all Layer 2 management features and certain Layer 3 features related to multicast data transmission and routing. These features shall include, but not be limited to:

- Support of remote and local setup and management via telnet, Secure Shell (SSHv2) or secure Web-based GUI and command line interfaces, and
- Support of the Simple Network Management Protocol (SNMP).
- Verify that the firewall can be accessed using the resident EIA-232 management port, a telecommunication network, or the Trivial File Transfer Protocol (TFTP).

U-4715B**ITS-296****Buncombe County**

Network Capabilities: Provide a firewall appliance that supports/complies with the following minimum requirements:

- Provide full implementation of IGMP v2,
- Provide full implementation of SNMPv3,
- Password manageable,
- Telnet/SSHv2,
- HTTP (Embedded Web Server) with Secure Sockets Layer (SSL), and
- Full implementation of RFC 783 (TFTP) to allow remote firmware upgrades.

Network Security: Provide a firewall appliance that supports/complies with the following (remotely) minimum network security requirements:

- Multi-level user passwords,
- RADIUS centralized password management (IEEE 802.1X),
- SNMPv3 encrypted authentication and access security,
- Support of the TFTP and SNTF.

7. Environmental Specifications

Provide a firewall appliance that adheres to the following environmental constraints if located within a climate-controlled environment:

- Operating temperature range: 32°F to 104°F,
- Storage temperature range: 14°F to 158°F, and
- Operating relative humidity range: 10% to 90%, non-condensing.

E. Network Management Software

Provide network management software that provides configuration, troubleshooting, security and system monitoring for the ITS communications network. Ensure that the system includes the following features:

- Able to create and maintain system and user identification and passwords,
- GUI interface,
- Syslog and SNMP alarm manager,
- Distributed server support for scalable management,
- Physical and logical topology for viewing every element on the network and how it is connected,
- Fault management and alarm view to see the health and status of every element on the network,
- Configuration management for configuring multiple elements and images, perform multi-step upgrades and archive device configurations,
- HTML report generator for Web-based reports,
- Switch configuration and monitoring,
- Inventory tool for the managed devices,
- VLAN manager,
- IP/MAC Address finder,
- Administration tool,
- Abstract Type Library for adding support for future hardware and software in the field,

◆ **Revision No. 1, April 10, 2017 - This document supersedes version originally issued and sealed by J. Todd Brooks, NCPE No. 017586 on 12/28/2016**

U-4715B**ITS-297****Buncombe County**

- Spanning Tree monitor,
- Monitoring of third-party devices,
- Support industry standard protocols such as SNMP, ANS.1, and XML,
- Handle commands from system clients via ASN.1 and/or XML-defined protocol over a standard TCP/IP connection,
- Command underlying nodes (devices such as switches),
- Report status of system nodes and alarms,
- Monitor system node connections,
- Store recent alarms in an internal database,
- Cooperate with another server in redundant set (when working in redundant configuration),
- Receive SNMP traps generated by network infrastructure, translate SNMP traps as system alarms, and send alarms as SNMP traps,
- Support remote configuration and diagnostics, and
- Restore video and connections in case of system component restarts.

Interface: Ensure that the network management software interface meets the following requirements:

- Network interface: Any network/telecom adapter supporting MS Windows TCP/IP stack.
- Network: Microsoft TCP/IP service software must be installed and configured correctly in the project's network environment.

Furnish client-server based application that supports installed client application and browser based client.

F. Uninterruptible Power Supply (UPS)

Provide UPS units that produce uninterruptible power and power conditioning for the devices listed below.

Provide external battery units as necessary to achieve the minimum runtime.

1. Standards

Ensure that the UPS units comply with the following standards:

- ANSI,
- ASTM,
- CSA, and
- UL.

2. Functional

Each UPS shall provide adequate capacity to run its respective equipment without commercial power for at least 20 minutes. Size the UPS units for the proposed loads. Provide load calculations for each configuration of equipment connecting to a UPS assuming a minimum run time of 20 minutes.

◆ **Revision No. 1, April 10, 2017 - This document supersedes version originally issued and sealed by J. Todd Brooks, NCPE No. 017586 on 12/28/2016**

U-4715B

ITS-298

Buncombe County

Ensure that the UPS and its remote monitoring software perform the following functions:

- Remote environmental monitoring of temperature and humidity,
- Data logging,
- Event logging,
- Fault notification,
- Hibernation,
- Radius authentication,
- Protocols: HTTP, HTTPS, IPv4, IPv6, SMTP (v1-v3), Telnet, SSH v2, SSL,
- Manage all network UPS units,
- Operating system shutdown,
- Load shedding to turn off selected devices or groups of devices,
- Outlet control to turn off, reboot, or shutdown outlets,
- Power event summary,
- Recommended actions,
- Risk assessment summary,
- Run command file, and
- System event log integration.

3. Physical Features

Supply each UPS unit described above with 25 percent spare outlets. Ensure that the UPS meets the following material requirements:

- Input voltage 120 volts nominal,
- Output voltage 120 volts nominal,
- Rack-mounted
- Sealed AGM type, maintenance free batteries,
- LCD control panel with status indicators and screen indicating operating mode, efficiency, wattage or amperage of load, input and output voltage, battery capacity and runtime,
- Ethernet network management card using 10/100 Base TX communications,
- USB interface port,
- Remote environmental monitoring of temperature and humidity with telnet management,
- Status lights: power on, power source and overload,
- Alarms: audible and remote notification,
- Manual power on/off switch, and
- Supply UPS unit with multi-pole noise filtering. Supply UPS with a terminal for connecting the UPS to a surge protection device.

4. Environmental Specifications

Verify that the UPS meets all specifications and is capable of performing all of its functions during and after being subjected to:

- Operating temperature: 0° F to 104° F,
- Operating relative humidity: 95%,
- Storage temperature: 5° F to 113° F, and
- Storage relative humidity: 95%.

Provide UPS units with UL 1449 surge protection and power filtering.

39.3. CONSTRUCTION METHODS

A. General

Ensure that all communications hardware is UL listed.

Verify that network/field/data patch cords meet all ANSI/EIA/TIA requirements for Category 6 four-pair shielded twisted pair cabling with solid copper conductors and RJ-45 connectors.

Receive approval for the System Design Report described in these Project Special Provisions before submitting product submittal data, purchasing, installing and configuring the computer and communications hardware at each facility.

Ensure the as-built documentation includes the identification of all IP addresses and VLANs, and associated hardware devices and device locations. Configure the Ethernet network so the traffic signals and CCTV cameras are in separate VLANs.

The Engineer will designate who their network administrator is for the ITS LAN. Upon project completion ensure that the network administrator will be able to remotely manage the Ethernet switches for switch configuration, performance monitoring, and troubleshooting.

B. Ethernet Switches

1. General

Ensure that all project IP addresses and VLAN IDs are assigned as defined in the System Design Report. Ensure that at a minimum, the switch configuration includes the following features: SNMP, STP, Port Security, all required VLANs, Unicast Routing protocol, and Multicast Routing protocol. Ensure unused switch ports are disabled.

Ensure that the network administrator will be able to manage each Ethernet switch individually or as a group/cluster for switch configuration, performance monitoring, and troubleshooting. Note that these specifications require additional minimum management intelligence (i.e., Layer 2+) typical of most current industrial Ethernet deployments. Ensure that the managed Ethernet switches include Layer 2+ capability providing architecture standardization, open connectivity (i.e., interoperability), bandwidth management, rate limiting, security filtering, and general integration management of an advanced Ethernet switching architecture.

Verify that fiber-optic jumpers consist of a length of cable that is connectorized on both ends, primarily used for interconnecting termination or patching facilities and/or equipment. Use fiber-optic jumpers that are factory assembled and connectorized and are certified by the fiber-optic jumpers' manufacturer to meet the relevant performance standards required below. Verify that

◆ **Revision No. 1, April 10, 2017 - This document supersedes version originally issued and sealed by J. Todd Brooks, NCPE No. 017586 on 12/28/2016**

U-4715B**ITS-300****Buncombe County**

network/field/data jumper cables meet all ANSI/EIA/TIA requirements for Category 6 four-pair shielded twisted pair cabling with solid copper conductors and RJ45 connectors.

2. Ethernet Core Switch

The Ethernet core switch shall act as the central data aggregation node for the new communications network. Locate the Ethernet core switch in the TMC as shown in the Plans and provide full Layer 3 functionality. Ensure that the Ethernet core switch communicates with the Ethernet edge switch at the City Transportation Department, firewall, existing and proposed ITS servers, field device cabinets, traffic signal controller and CCTV test cabinets, video server, video processing units and the proposed network video recorder(s) at Ethernet data transmission rates of 1 Gbps and the Ethernet edge switches at Ethernet data transmission rates of 100 Mbps. Connect the Ethernet core switch to the firewall in the TMC with Ethernet patch cords.

Install and configure the Ethernet core switch to be fully compatible with the Ethernet edge switches as defined in these Project Special Provisions. Ensure that at a minimum, the Ethernet core switch configuration includes following features: SNMP, STMP, Port Security, all required VLANs, Unicast Routing protocols, and Multicast Routing protocols. Ensure unused switch ports are disabled.

Ensure all fiber connections of the Ethernet core switch are connected to two pairs of single mode fiber strands via fiber-optic splice center for redundant communications.

3. Ethernet Edge Switch

Mount the Ethernet edge switch inside each field cabinet by securely fastening the Ethernet edge switch to the vertical rail of the equipment rack or to a shelf using manufacturer-recommended or Engineer-approved attachment methods, attachment hardware and fasteners. Ensure that the Ethernet edge switch is mounted securely in the cabinet and is fully accessible by field technicians without blocking access to other equipment. Verify that fiber-optic jumpers consist of a length of cable that is connectorized on both ends, primarily used for interconnecting termination or patching facilities and/or equipment. Use fiber-optic jumpers that are factory assembled and connectorized and are certified by the fiber-optic jumpers' manufacturer to meet the relevant performance standards required below. Verify that network/field/data jumper cables meet all ANSI/EIA/TIA requirements for Category 6 4-pair shielded twisted pair cabling with solid copper conductors and RJ45 connectors.

C. Firewall

Install the firewall appliance in a rack as shown in the Plans in the TMC. Connect the Ethernet core switch to the firewall in the TMC with Ethernet patch cords. Install the latest General Availability (GA) software release available from the manufacturer. Ensure all firewall appliances are running the same revision of software.

Configure a minimum of two (2) zones. Configure appropriate security policies to protect the internal ITS network from Internet-based attacks from the Internet. Configure an IPsec VPN on each firewall to connect to the City Transportation Department workstation via a secure link over the NCDOT dedicated fiber-optic communications network. Configure remote access VPN capability to allow NCDOT and City traffic services staff to access the network remotely via a secure connection from the Internet. If a VPN client is required for the remote access VPN, the Contractor shall provide a sufficient number of licenses for the required client software. If a server license is required, the Contractor shall provide all licenses for the server software as well.

◆ **Revision No. 1, April 10, 2017 - This document supersedes version originally issued and sealed by J. Todd Brooks, NCPE No. 017586 on 12/28/2016**

Ensure that the firewall appliance communicates with the Ethernet core switch at Gigabit Ethernet data transmission rates (1000 Mbps).

Ensure that the network administrator will be able to remotely manage each firewall appliance for configuration, performance monitoring, threat detection, and troubleshooting.

Install and configure the firewall appliance to be fully compatible with the Ethernet core switch.

D. Network Management Software

Install the Network Management Software (NMS) server application on the ITS communications server. Configure the NMS to monitor and manage the ITS servers, and Ethernet edge switches. Install software to provide access to the NMS software from the workstations and laptop computers connected to the network. Establish user access rights, designate who has administrative, manager and monitoring rights. Build the database through an automatic utility within the NMS or manually enter the data. Establish groupings of devices with like functions or features, this would include geographically related, device types, owners. Setup automatic database and configuration backups. Setup system and device alarms and alarm notifications.

Setup graphical network views. Use mapping images provided by manufacturers to geographically locate devices.

E. Uninterruptible Power Supply (UPS)

Install UPS unit in the communications rack in the TMC and the Ethernet core switch and ITS server to the UPS. Configure the UPS for remote monitoring.

39.4. MEASUREMENT AND PAYMENT

The Ethernet switches include all appropriate ports, cabling, grounding, redundancies, labeling and any integration between the Ethernet switches and the communications network as necessary to make a fully working installation. All power supplies, power cords, adapters, mounting hardware, DIN rail mounting brackets, DIN rails, connectors, serial cables, signs, decals, disconnect switches, installation materials, and configuration software necessary to complete this work, will be included and will be incidental.

Ethernet core switch will be measured and paid as the actual number of Ethernet core switches furnished, installed, and accepted.

Ethernet edge switch will be measured and paid as the actual number of Ethernet edge switches furnished, installed, and accepted.

Firewall will be measured and paid as the actual number of firewalls furnished, installed, and accepted.

Network management software will be measured and paid as lump sum furnished, installed, and accepted.

UPS (_____) will be measured and paid as the actual number of rack-mounted UPS units by location furnished, installed, and accepted.

Additional software licenses for the network management software shall be incidental to modify network management software.

◆ **Revision No. 1, April 10, 2017 - This document supersedes version originally issued and sealed by J. Todd Brooks, NCPE No. 017586 on 12/28/2016**

U-4715B

ITS-302

Buncombe County

No separate measurement will be made for SMFO jumpers, coaxial cables, communication cables, Ethernet patch cables, electrical cables, mounting hardware, nuts, bolts, brackets, connectors, risers, grounding equipment, surge suppression, or training as these will be considered incidental to the pay items listed above.

Payment will be made under:

| Pay Item | Pay Unit |
|-----------------------------|-----------------|
| Ethernet Core Switch | Each |
| Ethernet Edge Switch | Each |
| Firewall | Each |
| Network Management Software | Lump Sum |
| UPS (TMC) | Each |

◆ **Revision No. 1, April 10, 2017 - This document supersedes version originally issued and sealed by J. Todd Brooks, NCPE No. 017586 on 12/28/2016**

40. DIGITAL VIDEO EQUIPMENT

40.1. DESCRIPTION

Furnish and install a video graphics card for the existing video server to support the video management software. Furnish monitors to expand the existing monitor wall in the TMC and to add a new monitor in the City Transportation Department.

Provide USB-based joysticks for CCTV selection and control.

Provide network video recorder to record streaming digital video streams.

40.2. MATERIALS

A. Graphics Card for Existing Video Processing Unit

Provide one professional grade graphics card in the existing video processor to drive a total of eight HD displays per video processor unit meeting the following minimum requirements:

- Integrated video chipset controller,
- PCIe 3.0 compliant,
- RAM: 4 GB GDDR5,
- Display Ports: Four, with adaptors for HDMI eight monitor inputs,
- Maximum Display Port 1.2 Resolution: 4096 x 2160,
- Maximum Display Port 1.1 Resolution: 2560 x 2600,
- Memory bandwidth: 154 GBps,
- DirectX 11.1

B. Digital Video Monitors

Provide two 43-inch LED monitors to expand the existing monitor wall in the TMC and another monitor of the same size for the City Transportation Department. Provide only new video monitors; do not furnish used or refurbished monitors. Furnish monitors made by the same manufacturer ♦, LG Electronics, as the existing monitors. ♦ Provide power cords for all monitors of sufficient length to plug into duplex wall receptacle adjacent to monitor mounting location.

Provide mounting brackets specifically designed for mounting the size of LED monitors described below on both metal and wood stud walls. Provide brackets that allow vertical and horizontal tilt to optimize viewing angles. Provide brackets with locking setscrews to prevent the monitor from falling or sliding off the bracket. Provide all mounting hardware and fasteners and plywood backboard necessary for securely attaching monitor mount brackets to metal stud and wood stud walls. Provide monitors with a rated life of 50,000 hours.

Provide 43" monitors meeting the following requirements:

- Display Type: LED, widescreen flat panel,
- Mounting: Wall-mount,
- Resolution: 1,920 x 1,080 dpi,
- Pixel Pitch: .265 mm,
- Response Time: 8 ms,

♦ **Revision No. 1, April 10, 2017 - This document supersedes version originally issued and sealed by J. Todd Brooks, NCPE No. 017586 on 12/28/2016**

U-4715B**ITS-304****Buncombe County**

- Colors: Minimum 16.7 million colors,
- Horizontal Scanning Frequency: >85 kHz,
- Vertical Scanning Frequency: 50-86 Hz,
- Contrast Ratio: 1000:1,
- Aspect ratio: 16:9,
- Viewing Angle (Horizontal): 178 degrees,
- Viewing Angle (Vertical): 178 degrees,
- Brightness: 250 cd/m²,
- HDTV Supported Formats: 720p and 1080p,
- Digital Inputs: DisplayPort, HDMI, and DVI-D
- Analog Inputs: HD-15 VGA and,
- Audio Inputs: RCA Audio, stereo mini-jack, DisplayPort audio, HDMI audio.

Provide HDMI video cables with the monitors to reach from the video server outputs in the TMC to the wall monitors. Provide HDMI cables and connectors meeting the following requirements:

- Cable: Individually insulated, 26 AWG copper conductors,
- Connectors: 24x1 pin male on both ends,
- Pins: Gold Plated,
- RFI and EMI Noise Reduction: Clip on ferrites,
- Maximum Resolution: 4096 x 2160P at 24Hz,
- Bit Rate: 24-bit, and
- Bandwidth Rating: 14.93 Gbps at 340 MHz.

C. Network Video Recorder

The network video recorder (NVR) shall interface to the IP network and be able to record video images from the CCTV cameras to an internal hard drive, play back a video stream to wall monitor, and write those images to a DVD for viewing on a workstation or wall mounted monitor. Furnish and install one network-based NVRs in the TMC. Provide an NVR with the capability to record from IP streams 27 IP cameras each simultaneously. Record cameras at H.264 compression, 1080P resolution, camera resolution up to 5 Mbps, 30 frames per second with storage time for seven days. Provide an NVR meeting the following requirements:

- Processor: Intel Xeon E5-2407 processor at 2.40 GHz or greater, 6.4 Tbps,
- Memory: 2 x 4 GB RDIMM 1333 MHz, single rank,
- Hard Drive: 9 TB SATA, 7200 RPM, 64 MB cache 6 Gbps interface, RAID 5 hot plug,
- Network: Dual port 10/100/1000 Base T Ethernet with RJ-45 connectors,
- Video Card: 512 MB RAM with DirectX 11.1,
- Operating System: Windows 7 Professional, latest version.

Provide an NVR meeting the minimum power requirements:

- Input voltage: 90-135 V at 50/60 Hz, and
- Output wattage: 350 W.

◆ **Revision No. 1, April 10, 2017 - This document supersedes version originally issued and sealed by J. Todd Brooks, NCPE No. 017586 on 12/28/2016**

U-4715B**ITS-305****Buncombe County**

Provide an NVR meeting the minimum port requirements:

- Audio: Miniature phono plugs for line in, line out and microphone,
- Video: SVGA, and
- USB Port: Four USB 2.0 ports.

D. PTZ Joysticks

Provide new USB based joysticks. The joystick controls shall include a variable speed, joystick for precise PTZ control, jog control for video playback, a keypad for camera and monitor selection and control. The joysticks shall meet the following requirements:

- Input Voltage: 100-240 VAC, 50/60 Hz
- Keyboard Interface: USB 2.0 with cable and captive connectors
- Audio Output: Embedded speaker,
- Keyboard Keypad: Numeric keys 0-9, camera, monitor, and multiple Proportional PTZ, variable speed with zoom, iris, and focus controls, and
- Jog/Shuttle: Proportional, fast forward, reverse, and video transport.

The joysticks shall meet the following environmental requirements:

- Storage Temperature: 70 degrees F to 74 degrees F,
- Operating Temperature: 32 degrees F to 104 degrees F, and
- Storage Temperature: -40 degrees F to 149 degrees F.

40.3. CONSTRUCTION METHODS

A. General

Receive approval for the System Design Report described in these Project Special Provisions before submitting products submittal data, purchasing, installing and configuring the central video equipment described in this section of the Project Special Provisions.

B. Video Server

Relocate the video server from the existing communications rack in the control room to the new communications racks in the server room as shown in the Plans. Install the video graphics card in the existing video server. Reconnect the power cords to adjacent receptacles in the communications rack. Connect the video server to the Ethernet core switch. Update the existing video management software on the video server.

C. Digital Video Monitors

Use mounting brackets specifically designed for wall mounting 43” monitors. Ensure the mounting brackets are secured to wall studs or plywood backboard according to the manufacturer’s recommendations.

Mount the TMC monitors on the wall with the existing TMC monitors as shown in the Plans. The monitors shall align vertically and horizontally with each other as shown in the Plans.

◆ **Revision No. 1, April 10, 2017 - This document supersedes version originally issued and sealed by J. Todd Brooks, NCPE No. 017586 on 12/28/2016**

U-4715B**ITS-306****Buncombe County**

Mount the monitor in the City Transportation Department on the wall to be determined by the Engineer outside the Transportation Conference Room in City Hall.

Connect power cords to adjacent receptacles (provided by others) in wall.

Conceal all video cabling between each monitor and the video processing units in the wall as shown in the Plans using low voltage outlet boxes installed by others. Connect the HDMI video input of a monitor with a HDMI video output of the video server. Install ferrites to reduce RFI and EMI noise. Ensure when completed the power and video cables will be concealed behind the monitors.

D. Network Video Recorder

Install the NVRs in proposed server rack and connect to Ethernet network. Connect power cords to adjacent receptacles (provided by others) in wall. Connect the NVRs to the Ethernet core switch using Category 6 cable. Configure the NVRs for remote control and scheduled recording. Configure for H.264 compression at 1080P resolution and 30 frames per second. Configure the storage to overwrite after seven days.

E. PTZ Joysticks

Install joystick controls for camera control in the TMC. Connect each joystick with its respective workstation.

40.4. MEASUREMENT AND PAYMENT

The materials provided in this section include all appropriate ports, cabling, grounding, redundancies, labeling, and any integration between the devices and the communications network as necessary to make a fully working installation.

For furnish and install and for furnish only materials all power supplies, power cords, adapters, mounting hardware, DIN-rails, connectors, serial cables, HDMI cables, installation materials, and configuration software necessary to complete this work, are to be included and will be incidental to the pay items listed below.

Modify video server will be measured and paid as the actual number of video servers modified. The relocation of the video server to the new communications rack and installation of the graphics card will be included in this work.

Digital display monitor will be measured and paid as the actual number of 43" digital display monitors furnished, installed, and accepted.

Network video recorder will be measured and paid as the actual number of network video recorders, furnished, installed, and accepted.

PTZ joysticks will be measured and paid as the actual number of PTZ Joysticks furnished, installed, and accepted.

The video server will be paid for as an "ITS Server" as described in "Computer Hardware and Peripherals" section of these Project Special Provisions.

No separate measurement will be made for coaxial or serial cables, cable connectors, Ethernet cables between equipment housed within the same room/rack/cabinet, electrical cables, mounting hardware, nuts, bolts, brackets, connectors, grounding equipment, surge suppression or documentation as these will be considered incidental to the pay items listed above.

◆ **Revision No. 1, April 10, 2017 - This document supersedes version originally issued and sealed by J. Todd Brooks, NCPE No. 017586 on 12/28/2016**

U-4715B

ITS-307

Buncombe County

Payment will be made under:

Pay Item

Modify Video Server

Digital Display Monitor

Network Video Recorder

PTZ Joystick

Pay Unit

Each

Each

Each

Each

41. COMMUNICATIONS RACKS

41.1. DESCRIPTION

Furnish and install freestanding enclosed communications racks at the TMC.

41.2. MATERIALS

Provide freestanding enclosed communications racks for the TMC meeting these minimum performance requirements:

- All equipment shall comply with ANSI/EIA RS-310D,
- Provide frame and external components with zinc coating per ASTM B633,
- Paint interior and exterior components per RAL 7035, and
- The thermostatically controlled fans shall provide up to 300 cubic feet per minute (cfm) of exhaust. Thermostats shall monitor both humidity and temperature.

Provide freestanding enclosed communications racks meeting the following minimum material requirements:

- 19-inch EIA single-bay,
- Full size rack cabinet for TMC Server Room: 42 rack units high (approx. 78 inches),
- Nominal 4-inch-high ventilated base,
- Nominal depth: 30 inches,
- All-metal components,
- Full-height locking window door on the front,
- Urethane gaskets for window sealing,
- ¼-inch-thick Plexiglas® window panes,
- Solid metal removable side panels with bottom vents,
- Full-height solid metal door for the back of each cabinet, and
- Vented top with three integral, thermostatically controlled, prewired fans.
- Set of four (4) heavy-duty, locking casters on base.

Provide a means for the entry of multiple cables (fiber-optic, video and Ethernet) into the racks from the cable tray above the communications racks.

Mechanical: Construct all rack frames from 12-gauge, cold-formed steel. Construct all side panels and door panels of 14-gauge steel. Construct the vented base from 16-gauge steel. Construct the 19-inch electrical rack angles from 12-gauge steel.

Doors: Equip all doors with grounding brackets and doorstop kits. Door hinges shall have a maximum opening range of 130-140 degrees. Hinge kits shall permit left or right side mounting. Furnish the racks with tamper-proof hinges and removable hinge pins.

Provide the rack with flush swing handles with tamper resistant locks on all doors. Key all locks to the same key with two sets of keys provided for each unit. Locks shall have a three-point latch mechanism.

Wall Panels: Provide removable solid side panels with hanger tabs for easy alignment and assembly. Provide vents on front and rear panels, along with wire entry access plates with dust-tight seals.

◆ **Revision No. 1, April 10, 2017 - This document supersedes version originally issued and sealed by J. Todd Brooks, NCPE No. 017586 on 12/28/2016**

U-4715B

ITS-309

Buncombe County

Finish: Furnish factory-applied paint or powder-coating that is black in color on the exterior and interior of all components.

Furnish and install one metal shelf kit per communications rack. Provide each shelf the full width and depth of the rack angles and attach directly to the rack angles. Furnish and install one metal keyboard slide out drawer per full-height communications rack.

41.3. CONSTRUCTION METHODS

Ground the racks to a building ground.

Furnish and install an outlet strip and 10-foot power cord along one rear vertical rack frame. Furnish and install strips that use 120 VAC 60 Hz power and shall contain at least 10 outlets over the 70 inches for full size racks. Furnish and install grounding bus bar system to ground the rack-mounted electrical equipment. Equip door with grounding studs.

Furnish and install cable management hardware for attachment vertically along the rack frame and horizontally between 19-inch rack angles. Cable management hardware shall run vertically up one rear rack frame and shall include six horizontal runs per rack. Provide hardware including cable organizers and clamps to provide strain relief and cable mounting.

Install the full-height communications rack cabinets in the TMC as shown in the Plans.

Install a keyboard shelf at a height comfortable for operator use when sitting on a stool. Provide tamper-resistant but removable screws through hinges and exterior panels. Furnish any special tools required to remove tamper resistant screws.

Install shelf in the server rack for servers to be installed by others as shown in the Plans.

41.4. MEASUREMENT AND PAYMENT

Communications rack will be measured and paid as the actual number of full-size, freestanding, enclosed communications racks furnished, installed, and accepted.

No separate measurement and payment will be made for rack set-up and assembly, shelves, keyboard drawers, power strips, mounting of all accessories and equipment specified for installation within the rack, all brackets, fasteners, and hardware required for properly mounting equipment in the rack, as such materials and work will be considered incidental to furnishing and installing the communications racks.

Payment will be made under:

| Pay Item | Pay Unit |
|---------------------|-----------------|
| Communications Rack | Each |

U-4715B

ITS-310

Buncombe County

42. BUILDING MODIFICATIONS AND FIBER-OPTIC CABLE TERMINATION

42.1. DESCRIPTION

At locations called for in the Plans, route fiber-optic cable in new and/or existing conduits and install conduits into buildings as shown. Terminate fiber-optic cable in fiber-optic splice centers in buildings as shown in the Plans. Furnish and install cable and cable routing facilities as shown in the Plans.

All construction to reach a building is paid for using other pay items in these Project Special Provisions. All construction to enter a building (including all work from creating a new entrance or integrating with an existing entrance) and making internal provisions for terminating cables are covered under these building modification pay items. Electrical work inside the buildings and construction/relocation of walls/partitions will be performed by the City and the Department in their respective facilities.

42.2. MATERIALS

A. General

Use risers and conduit materials as called for in the *Standard Specifications* or these Project Special Provisions.

Use caulking and sealing materials for sealing entrances into buildings as approved by the Engineer.

Furnish Ethernet outlet boxes equipped with both a single RJ-45 jack and two RJ-45 jacks as shown in the Plans.

B. Fiber-Optic Splicing and Termination

Furnish SMFO pigtails with each splice housing, connector housing and interconnect center. Provide pigtails that are a maximum of 6 feet in length with a factory assembled LC connectors on one end. Ensure that the SMFO pigtails meet the operating characteristics of the SMFO cable with which it is to be coupled.

Furnish SMFO jumpers that are a minimum of 3 feet in length with factory assembled LC connectors on one end (i.e., the splice/interconnect center end) and, on the other end, factory-assembled connectors of the same type provided on the Ethernet edge switch and provided on the Ethernet core switch. Ensure that SMFO jumpers meet the operating characteristics of the SMFO cable with which it is to be coupled. Provide all of SMFO jumpers with all of the connector combinations necessary to provide the connectivity indicated in the Plans and required by these Project Special Provisions to produce a fully-functional Ethernet communications system.

Provide connector panels with LC-type connectors for connector housings and interconnect centers installed in all facilities.

For each splice housing and interconnect center, provide splice trays that hold, protect, and organize optical fibers, and secure fibers inside splice tray. Design and size splice trays to be dielectric, to accommodate all fibers entering the splice tray, and to provide sufficient space to prevent microbending of optical fibers.

◆ **Revision No. 1, April 10, 2017 - This document supersedes version originally issued and sealed by J. Todd Brooks, NCPE No. 017586 on 12/28/2016**

U-4715B

ITS-311

Buncombe County

C. Traffic Management Center (TMC) Building Modifications

1. Rack-Mounted Splice Centers

Furnish rack-mountable modular splice centers each comprising integrated connector panels and splice trays for splicing the fibers in the incoming signal system trunk cables to SMFO fiber-optic pigtailed and terminating on patch panels in the communications cabinet being installed in the TMC (i.e., one splice center for each incoming cable). Each connector housing shall have LC-compatible connector panels and shall have a capacity for terminating a minimum of 96 fibers on the connector panels as called for in the Plans. Each connector housing shall occupy no more than 3 rack units. Provide a matching splice housing for each connector housing and provide necessary splice trays for fusion splicing the incoming single-mode fibers in incoming 96-fiber trunk cables to the pigtailed. Each splice housing shall occupy no more than 3 rack units, shall be of the same manufacturer as the associated connector housing and designed to work with the connector housing. Each splice housing shall have the capacity to splice at least 96 fibers to pigtailed. Provide all hardware needed to install the splice centers units in the communications rack.

2. Cable Entry

Provide a 2" RGS riser from a proposed oversized junction box in the sidewalk up the exterior wall of the building into the server room. Furnish an exterior wall-mounted junction box to transition between the exterior wall mounted riser and the conduit through the concrete block wall. Provide a NEMA 3R box with minimum dimensions of 12" w x 12" h x 6" d so that the fiber-optic cable manufacturer's recommended minimum bend radius is not violated. Provide strain relief hardware for the fiber-optic cable in the riser. Core drill through block wall as shown in the plans and insert 2" RGS conduit. Install bushings and lock nuts to protect cables. Seal with waterproof caulk.

3. Cable Tray

Furnish a cable tray between walls and communications racks as show in the Plans. Provide a wire mesh cable tray 12" wide and 2" high. Provide a cable tray system using stainless steel. Provide hardware to secure an end of the cable tray to the wall and to secure the side of the cable tray to wall when the tray runs parallel to the wall. Provide a vertical cable tray transition with drop out kits from the cable tray to the top of each communications rack. Secure the cable at least every six feet to the wall. Provide manufacturer recommended splice kits to connect sections of cable trays together. Provide a manufactured tee section to join cable trays at 90 degree angles. Use stainless steel hardware.

4. Network Wiring

Furnish all conduit, conduit fittings, outlet bodies, cover plates, conduit straps, rod-to-beam fasteners, conduit fasteners, new conduit and network boxes (i.e., Ethernet outlets) in the TMC to convey Ethernet cabling within the TMC as shown in the Plans.

Install replacement Ethernet cabling to the Deputy Division Traffic Engineer's office from the Communications Rack 2 in the server room. Use the cable tray in the server room to meet the existing network and telephone cable running through the signal and sign shops from the TMC. Lash the new Ethernet cable to the existing cables. Route the new Ethernet cable through the partition wall as shown in the Plans and install network outlet box.

◆ **Revision No. 1, April 10, 2017 - This document supersedes version originally issued and sealed by J. Todd Brooks, NCPE No. 017586 on 12/28/2016**

U-4715B

ITS-312

Buncombe County

D. City Hall Building Modifications

1. Wall-Mounted Splice Housing

Furnish a wall-mounted splice housing for fusion splicing (i.e., transitioning) the outdoor-rated fiber-optic cable to the indoor, plenum-rated fiber-optic cable in the telecommunications room on the basement floor of the City Hall Building. Size the splice housing for the number of cables and fibers to be spliced in accordance with the Plans and to fit within the space available on the wall within the telecommunications closet. Provide all necessary splice trays and splice protectors and a bracket for securing the splice trays inside the housing. Provide splice trays that are designed for use with the splice housing being provided. Furnish all fasteners and mounting hardware needed to mount the splice housing to the wall of the telecommunications room as shown in the Plans. Provide a splice housing with grommets cable ports in both the top and bottom of the box for feeding fiber-optic cables in and out of the box. Furnish a splice housing with a solid, removable front access door that is secured to the enclosure with a bolt or quarter-turn latch. Fabricate the enclosure from powder-coated aluminum or steel.

2. Wall-Mounted Interconnect Center

Furnish a compact, wall-mounted interconnect center for terminating a fiber-optic drop cable adjacent to the City Remote Access Workstation in the Transportation Department on the Mezzanine Level of City Hall. Provide an interconnect center that is equipped with the following:

- Durable metal housing with powder-coated finish.
- Connector panel with a minimum of twelve LC connectors
- Blank panels to cover any unused connector panel slots.
- Capacity to terminate at least 24 fibers on connector panels with LC connectors.
- A hinged metallic door to cover and protect the jumpers and the connector panel(s).
- Locks with a minimum of two keys to secure the jumper/connector panel door and the door covering the splice trays and pigtails.
- Openings or ports at the top and bottom of the housing to permit cables to pass in and out of the interconnect center with the connector panel one side of the interconnect center.

Provide all necessary splice trays, splice protectors and SMFO pigtails for terminating the drop cable inside the interconnect center. Provide all fasteners and wall anchors needed to securely attach the wall-mounted interconnect center to the wall inside Transportation Department on the Mezzanine Level of City Hall as shown in the Plans.

3. Wall-Mount Enclosure for Edge Switch

Furnish a compact, wall-mount NEMA Type 12 enclosure to cabinet to house the Ethernet edge switch adjacent to the City Remote Access Workstation in the Transportation Department on the Mezzanine Level of City Hall.

◆ **Revision No. 1, April 10, 2017 - This document supersedes version originally issued and sealed by J. Todd Brooks, NCPE No. 017586 on 12/28/2016**

U-4715B**ITS-313****Buncombe County**

The cabinet shall be designed to mount flat against a wall and have the following features:

- Constructed of 18-gauge or better steel with a black powder-coated finish.
- Have a hinged front cover with a quarter-turn locking latch to secure the cabinet, along with at least 2 keys.
- Have ground studs at rear or bottom of cabinet.
- Sized to house a single Ethernet edge switch either surface mounted to the back panel of the enclosure or DIN rail mounted to the back of the enclosure, but no more than 12 inches wide to ensure that it can be mounted within the available wall space in the communications closet as shown in the Plans.
- Have grommeted holes in top and bottom of the enclosure for passing cables in and out of the enclosure.

Provide all fasteners and wall anchors needed to securely attach the enclosure to the wall inside Transportation Department on the Mezzanine Level of City Hall as shown in the Plans.

4. Conduit, Conduit Fasteners and Fittings for Entrances

Furnish all conduit, conduit fittings, outlet bodies, conduit straps, conduit fasteners, bushings, duct sealant, heat shrink tubing, and any other hardware required to provide cable entrance into building.

E. Division 13 Office Building Modifications

Furnish all equipment, materials and hardware needed to install fiber-optic communications cable into the ground floor telecommunications room of the Division 13 Office and terminate it in a wall-mounted interconnect center as shown in the Plans.

Prior to submitting shop drawings and ordering the proposed wall-mounted interconnect center and excess length storage box, visit the telecommunications room to take/confirm measurements and confirm the amount of space available on the wall for mounting these two enclosures. Contact Mr. Cole Hood, Division Project Development Engineer, at 828-251-6171 at least 14 days in advance to make arrangements for access to the room. Provide a wall-mounted interconnect center and storage box sized to fit within the space available without relocating any of the existing equipment mounted on the same wall.

1. Wall-Mounted Interconnect Center

Furnish a compact, modular interconnect center designed to be wall-mounted for splicing and terminating all 24 fibers in the incoming 24-fiber-optic cable at the Division 13 Office. Furnish an interconnect center that complies with the requirements of interconnect centers in the "Splice Centers" section of these Project Special Provisions, except the unit shall be wall mounted on the concrete block wall.

Provide an interconnect center that is sized to fit within the space available as shown in the Plans and that is equipped with the following:

- Durable metal housing with powder-coated finish.
- Connector panels with a minimum of 24 SC connectors
- Blank panels to cover any unused connector panel slots.

◆ **Revision No. 1, April 10, 2017 - This document supersedes version originally issued and sealed by J. Todd Brooks, NCPE No. 017586 on 12/28/2016**

U-4715B**ITS-314****Buncombe County**

- Capacity to terminate a minimum of 24 fibers on connector panels with SC connectors.
- A hinged metallic door to cover and protect the jumpers and the connector panel(s).
- Locks with a minimum of two keys to secure the jumper/connector panel door and the door covering the splice trays and pigtails.
- Openings or ports at the top and bottom of the housing to permit cables to pass in and out of the interconnect center with the connector panel one side of the interconnect center.

Provide all necessary splice trays, splice protectors and SMFO pigtails for terminating the drop cable inside the interconnect center. Provide all fasteners and wall anchors needed to securely attach the wall-mounted interconnect center to the wall inside the communications closet in the Division 13 Office as shown in the Plans.

2. Cable Over-length Storage Box

Furnish a wall-mounted enclosure for storing excess fiber-optic cable upon completion of splicing and termination within the wall-mounted interconnect center and mounting of the interconnect center on the wall. Provide the cable over-length storage box with all necessary hardware and fasteners for mounting the enclosure on the wall in the telecommunications room of the Division 13 Office building. Mount the box beside the new wall-mounted interconnect center as shown in the Plans. Provide an enclosure fabricated polycarbonate, fiberglass, aluminum or steel. If aluminum or steel, provide with a finish that is either natural milled aluminum, powder-coated, or galvanized. Provide an enclosure with a solid, removable front cover that is secured to the enclosure using screws. Ensure the box is equipped with storage guides inside to coil and store excess fiber-optic cable without violating the cable manufacturer's specified minimum bend radius. On one side of the box, provide two holes, one for cable entry into and one for cable exit from the enclosure. Locate one hole near each corner of the box along that side. Provide U-shaped holes that are completely open on the front cover edge of the box to allow the cable to be lifted out of and laid into the hole (slot) without having to feed the cable end through an fully enclosed hole. Store a minimum of 20 LF of fiber-optic cable inside the box following splicing and termination in the interconnect center.

3. Cable Ties

Furnish heavy-duty, nylon cable ties for attaching the SMFO cable to the concrete block wall inside the communications room. Provide cable ties designed for mounting to a wall via a screw anchor inserted through a hole fabricated into the head of the cable tie. Furnish all required fasteners/anchors required to attach the cable ties to the concrete block wall.

42.3. CONSTRUCTION METHODS

A. General

Contact Engineer prior to entering any building. Coordinate and obtain approval from Engineer regarding allowable working time in buildings.

Whenever possible, use existing cable raceways, ducts and drop ceilings to route fiber-optic cable.

◆ **Revision No. 1, April 10, 2017 - This document supersedes version originally issued and sealed by J. Todd Brooks, NCPE No. 017586 on 12/28/2016**

U-4715B**ITS-315****Buncombe County**

When working inside the buildings, cover all furnishings, including chairs and electronic and computer equipment with drop cloths to protect them from debris and to aid in cleanup. Replace the raised floor panels and ceiling panels and clean up all dust and debris by the end of each work period unless otherwise approved by the Engineer. Replace any floor panels damaged during installation of the above ceiling conduit at no expense to the Department.

Perform all work called for in the Plans to install cable in conduits and cable raceways, and to route cabling under raised floors, above suspended ceilings, and new and existing conduits.

Terminate all optical fibers in splice centers unless otherwise shown on the Plans.

Install splice centers with connector panels, splice trays, storage for slack cable or fibers, mounting and strain relief hardware, and all necessary hardware. Comply with all requirements of the "Fiber-Optic Splice Centers" section of these Project Special Provisions.

Apply an Engineer-approved, UL-listed fire-stop sealant (putty, caulk, mortar, etc.) to reseal gaps between any existing conduits and holes through interior building walls and partitions.

B. Traffic Management Center (TMC)

1. General Requirements

Install equipment and route cable into the TMC through existing rigid metal conduit and IMC conduit provided by others as shown in the Plans. Contact Durwin Rice, Deputy Division Traffic Engineer, at (828) 298-0094 at least 30 days in advance of work to confirm work schedule, work restrictions and to make arrangements for gaining access to the building. Perform all work in accordance with NESC regulations and guidelines.

When working inside the Division 13 Traffic Services Building, cover all furnishings, including chairs and electronic/computer equipment with drop cloths to protect them from debris from above-ceiling work and to aid in cleanup. Carefully remove ceiling panels and fiberglass insulation above the removed panels. Replace the insulation and panels and clean up all dust and debris by the end of each work period unless otherwise approved by the Engineer. Replace any drop ceiling panels damaged during installation of the above ceiling conduit at no expense to the Department.

2. Cable Entry

Core drill new conduit entrance into building as shown in the Plans. Install an exterior wall mounted junction box to transition between the conduit riser and the cable entry through the concrete block wall. Insert a piece of 2-inch rigid galvanized conduit through the new hole, attach the new riser, and seal gaps between the hole and the conduit/riser. Seal the conduit drill hole with waterproof grout made for masonry applications. Secure the junction box with masonry anchors. Secure conduit riser and conduit through the wall with washers and lock nuts. Secure the conduit inside the server room with washers and a lock nut.

3. Signal System FO and Other Cables and TMC Equipment

Install the required rack-mounted splice centers in the communications racks in the TMC as shown in the Plans. Pull the proposed signal system fiber-optic communications cables inside the building. Leave a pull tape for use by others for pulling additional fiber-optic communications cables into the TMC at a later date.

◆ **Revision No. 1, April 10, 2017 - This document supersedes version originally issued and sealed by J. Todd Brooks, NCPE No. 017586 on 12/28/2016**

U-4715B**ITS-316****Buncombe County**

Fusion splice all fibers in the entering fiber-optic cables to SMFO pigtails inside rack-mounted splice housing, then connect the pigtails to the appropriate connectors in the connector housing. Terminate all pigtails from the incoming cable. Clearly label the patch panels of the connector housing center using an approved labeling method. Install SMFO jumpers between the connector panels and the Ethernet core switch. Store a minimum of 20 LF of each fiber-optic cable inside the communications rack that contains the splice center.

Relocate the existing HDMI video cable from its present terminus in the existing communications rack to the video server in the proposed communication rack as shown in the Plans.

Install new Ethernet cable for the outlets as shown in the Plans. Terminate the cable in the control room in network jacks. Terminate the Ethernet cable in the server room in the Ethernet patch panel in the communications rack.

C. City Hall

1. General Requirements

Install equipment and route cables into City Hall to the communications closet on the Mezzanine Level and to the City's remote monitoring workstation as shown in the Plans. Contact Kevin Hymel, City of Asheville Technical Services Manager, at 828-259-5517 and Jeff Moore, City Traffic Engineer, at (828) 259-5943 at least 30 days in advance of work to confirm work schedule, work restrictions and to make arrangements for gaining access to the building. Perform all work in accordance with NESC regulations and guidelines.

Prior to the Contractor beginning work inside City Hall, City personnel will flag/mark the existing conduits and cable raceways to be used inside City Hall to route the new fiber-optic communications cable from its entry point into the City Hall building to its termination point on the Mezzanine Level. Examine the route prior to commencing work inside City Hall to develop an understanding of the work, equipment and materials required to route the cable via this route inside City Hall. Carefully inspect the proposed route above the Mezzanine Level drop ceiling prior to verify route of the cable from the communications closet to the remote workstation and determine the appropriate method for routing the new communications cable above the drop ceiling.

When working inside City Hall, cover all furnishings, including chairs and electronic/computer equipment with drop cloths to protect them from debris from above-ceiling work and to aid in cleanup. Carefully remove ceiling panels and any fiberglass insulation above the removed panels. Replace the insulation and panels and clean up all dust and debris by the end of each work period unless otherwise approved by the Engineer. Replace any drop ceiling panels damaged during installation of the above ceiling conduit at no expense to the Department.

When working in a stairwell, do not block access to fire doors or to the stairs at any time and keep floor in front of stairwell door and stairs free from tripping hazards.

2. Building Entry

Coordinate with the City's Technical Services Manager at least one week prior to beginning work so that the Technical Services Manager can notify the owner of the existing communications cables that use the existing cable entry point into the City Hall Building. Be advised that the owner of the other communications cables, ERC, may require that an ERC

◆ **Revision No. 1, April 10, 2017 - This document supersedes version originally issued and sealed by J. Todd Brooks, NCPE No. 017586 on 12/28/2016**

U-4715B**ITS-317****Buncombe County**

representative be present while the riser is being installed on the exterior of the City Hall Building and the new signal system communications cable is pulled through the cable entry hole currently occupied by ERC cables in order to observe the installation work and to ensure that appropriate measures are taken to protect the existing ERC cables from damage. Coordinate with the City Technical Services Manager and the ERC representative to schedule the building entry work on a mutually agreed upon date and time.

Install the rigid galvanized steel riser with head shrink tubing on the exterior of the City Hall Building at the location shown in the Plans, securing the riser to the building using galvanized conduit straps and masonry anchors. Carefully cut a 1" round hole in the existing wall-mounted PVC junction box in which a loop of ERC fiber-optic cable is stored, then install a rigid galvanized watertight conduit hub in the hole and attach the new riser to the junction box using the hub. Do not remove the existing PVC junction box. Feed the fiber-optic communications cable for the signal system down through the new riser, loop it through the junction box and then feed it through the building entry hole. Apply heat-shrink tubing to the new riser, re-attach the junction box and conduit covers.

3. Basement Level Telecommunications Closet

Route cable from building entry point to the communications closet on the basement level of City Hall using the existing conduits and risers flagged/identified by City personnel. Install a wall-mounted splice center in the telecommunications closet on the basement floor as shown in the Plans. Fusion splice all fibers (i.e., butt splice) from the incoming outdoor-rated cable to the fibers in the outgoing plenum-rated cable destined for the Transportation Department on the Mezzanine Level in the splice center.

4. Mezzanine Level

Route the plenum-rated cable from the telco closet in the basement to the closet adjacent to the City Traffic Engineer's office on the Mezzanine Level using the spare risers and conduits identified by City staff.

Route the new plenum-rated fiber-optic communications cable from the communications closet adjacent to the City Traffic Engineer's office over the drop ceiling to the new remote workstation outside the Transportation Conference. Use the existing cable trays and raceways above the drop ceiling to rout the new fiber-optic cable.

At a point directly above the proposed location of the wall-mounted interconnect center in the remote work center, neatly cut a round hole approximately 1 inch in diameter in drop ceiling panel directly above the wall-mounted interconnect center. Install 1-inch non-metallic tubing through the hole and down to the interconnect center, securing it to the wall using straps at appropriate intervals. Feed the plenum-rated communications cable down through the tubing and into the wall-mounted interconnect center. Install the wall-mounted interconnect center on the wall in the remote workstation room as shown in the Plans. Fusion splice all fibers in the entering fiber-optic cables to SMFO pigtailed inside the interconnect center, then connect the pigtailed to the appropriate connectors on the interconnect center patch panel. Clearly label the connector panels using an approved labeling method.

Mount the Ethernet edge switch on a wall-mounted enclosure installed next to the wall-mounted interconnect center. Plug the power supply for the edge switch into a nearby wall receptacle and

◆ **Revision No. 1, April 10, 2017 - This document supersedes version originally issued and sealed by J. Todd Brooks, NCPE No. 017586 on 12/28/2016**

U-4715B**ITS-318****Buncombe County**

furnish and install wire molding to conceal the power cord between the wall-mount edge switch enclosure and the receptacle.

Install SMFO jumpers between the connector panels and the Ethernet edge switch in the adjacent wall-mounted enclosure.

Install the computer workstation on the furniture provided by the City. Install an Ethernet cable to connect the Ethernet edge switch to the computer workstation.

D. Division 13 Office

Contact Mr. Cole Hood, Division Project Development Engineer, at 828-251-6171 at least 14 days in advance of work to confirm work schedule, work restrictions and to make arrangements for gaining access to the Division 13 office building and the ground floor telecommunications room.

Take necessary precautions to prevent disturbing or damaging existing cables and equipment housed in existing conduits and inside the communications room. Confirm the space available for installing wall-mounted equipment and enclosures inside the communications room as shown in the Plans and use only equipment and enclosures that fit within the spaces available. Perform all work in accordance with NESC regulations and guidelines.

Feed the new fiber-optic cable through the existing weatherhead and the existing PVC conduit through the exterior wall of the building and into the communications room as shown in the Plans. Route the cable along the top of the west wall of the room from the entry point to the wall-mounted interconnect center and excess-length cable storage box using mounted-style cable ties to attach the cable securely to the wall.

Mount the new wall-mounted interconnect center on the west wall of the communications room above the existing plywood panel on the right side of the wall as shown in the Plans using screw anchors designed for concrete block walls. Mount the excess length box adjacent to the wall-mounted interconnect center using screw anchors designed for concrete block walls.

Fusion splice all of the incoming fiber-optic cable fibers to SMFO pigtailed and terminate them on the connector panel in the interconnect center. Install a communications cable identification marker (i.e., cable wrap) on the fiber-optic cable on both sides of the cable entry point into the building and just outside the point where the cable enters the interconnect center. Install dust caps on all connectors on the interconnect center patch panel. Store excess cable.

42.4. MEASUREMENT AND PAYMENT

TMC modifications will be measured and paid at the contract lump sum price. The price and payment will be full compensation for all work required to route and terminate the fiber-optic cable into the TMC as shown in the Plans, as well as any other work not called for under other items but required to accomplish the building modifications.

City Hall modifications will be measured and paid at the contract lump sum price. The price and payment will be full compensation for all work required to install conduit and route and terminate the fiber-optic cable into City Hall as shown in the Plans, as well as any other work not called for under other items but required to accomplish the building modifications.

Division 13 office modifications will be measured and paid at the contract lump sum price. The price and payment will be full compensation for all work required to route the fiber-optic

◆ **Revision No. 1, April 10, 2017 - This document supersedes version originally issued and sealed by J. Todd Brooks, NCPE No. 017586 on 12/28/2016**

U-4715B**ITS-319****Buncombe County**

cable into the building as shown in the Plans, and then terminate the fiber-optic cable in a wall-mounted interconnect center, as well as any other work not called for under other items but required to accomplish the building modifications.

The Ethernet cables in the TMC and in City Hall will be measured and paid for in accordance with the "Ethernet Cable" section of these Project Special Provisions.

No separate payment will be made for rack-mounted interconnect centers, patch panels, splice trays, splicing, conduit, conduit fittings, conduit hangers, conduit surface mounting hardware and brackets, duplex electrical receptacles and Ethernet outlet boxes with RJ-45 jacks as these will be considered incidental to the building modifications.

No separate measurement will be made for mounting hardware, nuts, bolts, concrete/masonry anchors, brackets, connectors, grounding equipment as these will be considered incidental to the pay items listed above. No separate payment will be made for wall-mount cabinets/junction boxes, splice housings, connector housings, interconnect centers, patch panels, splice trays, splicing, conduit, conduit fittings, conduit hangers, conduit surface mounting hardware and brackets, and fire-stop sealant as these will be considered incidental to the building modifications.

No separate measurement will be made for computer hardware, Ethernet switches, video head-end equipment, and rack cabinets, as these will be measured and paid for elsewhere in these Project Special Provisions.

Computer hardware, Ethernet switches, digital video display monitors, video head-end equipment and communications racks will be measured and paid for separately in accordance with other sections of these Project Special Provisions.

Payment will be made under:

| Pay Item | Pay Unit |
|----------------------------------|-----------------|
| TMC Modifications | Lump Sum |
| City Hall Modifications | Lump Sum |
| Division 13 Office Modifications | Lump Sum |

◆ **Revision No. 1, April 10, 2017 - This document supersedes version originally issued and sealed by J. Todd Brooks, NCPE No. 017586 on 12/28/2016**

43. SUBMITTAL DATA AND DOCUMENTATION

43.1. DESCRIPTION

Provide project documentation for Department review and approval as described below.

43.2. SUBMITTALS

A. General

The intent of this subsection of the Project Special Provisions is to provide the requirements for submittal data (i.e., shop drawings, catalogue cuts, manufacturers' literature, proposed changes to splice drawings, construction schedule, system design report, etc.) and the process by which submittal data will be reviewed.

Provide all submittal documentation in either 8½" x 11" or 11" x 17" format. No documentation smaller than 8½" x 11" will be accepted. No documentation larger than 11" x 17" will be accepted without the prior approval of the Engineer. All submittals will be reviewed and approved by the Department. Absence of comment will not grant approval.

B. Project Construction Schedule

Prepare and submit for approval by the Engineer a schedule of the proposed working progress on the project in accordance with the instructions and on forms furnished by the Department. Update and submit the schedule no less than monthly.

The project schedule shall include a monthly schedule of values. At the end of each calendar month shown on the schedule, show a value (in dollars) of the cumulative project work projected to be completed. The initially proposed project schedule shall be submitted no later than 5 business days prior to the date of the project preconstruction conference and shall be approved before any work is begun on the project. Update and submit the project schedule five business days prior to the monthly construction meetings.

When conditions beyond the Contractor's control have adversely affected the Contractor's progress, or the Department has extended the completion date, the Contractor may submit a revised progress schedule to the Department for approval. Such revised progress schedule will not be approved unless accompanied by a detailed written statement giving the Contractor's reasons for the proposed revision.

The project construction schedule shall show at least:

- Major Activities,
- Critical Path,
- Task Dependencies,
- Float Time for Each Task,
- Project Start and Completion,
- Task Durations,
- Task Begin and End Dates,
- Milestones,
- Material Submittals,
- Submittal Review Periods,

◆ **Revision No. 1, April 10, 2017 - This document supersedes version originally issued and sealed by J. Todd Brooks, NCPE No. 017586 on 12/28/2016**

U-4715B**ITS-321****Buncombe County**

- Equipment Deliveries,
- Sample and Material Testing,
- Acceptance and Demonstration Testing,
- Training,
- Observation Period,
- Final Acceptance.

C. Qualified Products

Furnish new equipment, materials, and hardware unless otherwise required. Inscribe manufacturer's name, model number, serial number, and any additional information needed for proper identification on each piece of equipment housed in a case or housing.

The ITS & Signals Qualified Products List (QPL) is available on the North Carolina Department of Transportation's Website at:

<https://connect.ncdot.gov/resources/safety/Pages/ITS-and-Signals-Qualified-Products.aspx>

Certain signal and communications equipment, material, and hardware shall be pre-approved on the QPL by the date of installation. Equipment, material, and hardware not pre-approved when required will not be allowed for use on the project. Consult the QPL Website to obtain pre-approval procedures.

D. System Design Report

Prepare a System Design Report to describe the proposed network architecture and its configuration. Provide schematics to illustrate the network architecture and configuration, in addition to the written description. Provide a detailed description of the hardware and software to be installed. The report shall depict and describe the entire layout of the equipment and their connectivity. Provide a detailed listing of the hardware including brand and model numbers, functions and descriptions. Provide a detailed listing of the VLAN configuration and IP addresses. Bind the report either in a 3-ring notebook or other type of binding approved by the Engineer.

Submit the bound report and obtain approval before providing material submittals for the following packages of items as described below: central video equipment, software, computer hardware, and communications equipment.

E. Fiber-optic Splicing Drawings

Submit drawings that illustrate any proposed changes to the fiber-optic splicing details for Department review and approval at least 10 working days prior to beginning fiber-optic splicing. Do not perform any fiber-optic splicing until the Department approves the proposed changes.

F. Submittal Requirements

Provide written certification to the Department that all Contractor-furnished material is in accordance with the contract. When requested by the Department, provide additional certifications from independent testing laboratories and sufficient data to verify item meets applicable specifications. Ensure additional certification states the testing laboratory is independent of the material manufacturer and neither the laboratory nor the manufacturer has a vested interest in the other.

◆ **Revision No. 1, April 10, 2017 - This document supersedes version originally issued and sealed by J. Todd Brooks, NCPE No. 017586 on 12/28/2016**

U-4715B**ITS-322****Buncombe County**

The intent of submittals is to show that the materials completely meet the requirements of the Plans and Project Special Provisions and how the Contractor intends to construct or configure the materials. The Contractor shall clearly demonstrate in the submittals that the desired materials shall meet or exceed the requirements of the Plans and Project Special Provisions. Each submittal shall be sufficiently complete and detailed for the Department to review and approve the submittal. If the Department deems the submittal insufficient in detail or completeness for review or approval, the submittal will be returned as rejected. Additional time will not be granted for resubmittal.

Before material submittal data begins, provide to the Department a list of all submittals with approximate dates of submission that the Contractor intends to make. It is incumbent upon the Contractor to schedule reviews in a timely manner that will not delay his schedule.

Certain groups of materials are related in function and operate as a subsystem together. To ensure individual and subsystem compliance with the project requirements materials shall be submitted as packages as follows:

| Submittal Package | Description |
|------------------------------------|---|
| System Design Report | See "System Design Report" subsection above. |
| Controllers and Cabinets | 2070E Controllers, 332A and 336S Cabinets, Conflict Monitors, Base Adapters, Base Extenders, Preformed Cabinet Foundations, Special Coating for Cabinets and Base Extenders/Adapters |
| Fiber-optic Cable | Fiber-optic Cable, Drop Cables, Splice Enclosures, Interconnect Centers, Splice Trays, Cable Addition Kits, Delineator Markers, Communications Cable Identification Markers |
| CCTV Equipment | Composite Cable, CCTV camera, CCTV cabinet |
| Video Equipment* | Video Graphics Card, Video Monitors, Video Joysticks |
| Wireless Communications Equipment* | 2.4 GHz Ethernet radio system, 900 MHz Ethernet radios, Ethernet radio antennas and antenna mounting hardware, RF disconnect switch, RF warning sign and decals, lightning arrestors, Pole-Mount Radio Cabinet, |
| Computer Hardware | ITS Servers, Workstations, Laptops, Network Printer, Ethernet Cable |
| Communications Equipment* | Ethernet Core Switch, Firewall, Ethernet Edge Switches, KVM Switch, Network Management Software (see "Communications Hardware" section of these Project Special Provisions for further requirements); Communications Racks. |

◆ **Revision No. 1, April 10, 2017 - This document supersedes version originally issued and sealed by J. Todd Brooks, NCPE No. 017586 on 12/28/2016**

U-4715B

ITS-323

Buncombe County

| Submittal Package | Description |
|----------------------|---|
| Field Infrastructure | Conduit, Junction Boxes, Terminal Splice Boxes/Cabinets, Electrical Service Equipment (Disconnects, Meter Bases, Combination Panels), Pole-Mount Radio Cabinet, Heat Shrink Tubing and Retrofit Kits, Signal Heads, Pushbutton Integrated Accessible Pedestrian Signals, Stainless Steel Banding Hardware, and Misc. Hardware |

* Indicates submittal packages that cannot be submitted for review until the System Design Report has been submitted and approved.

Identify all proprietary parts in Contractor-furnished material. The Department reserves the right to reject material that uses proprietary components not commercially available off-the-shelf products.

For Contractor-furnished material listed on the QPL, furnish submittals in the format defined by the QPL.

For Contractor-furnished material not on the QPL, furnish three copies of the equipment list including three copies of catalog cuts. Identify proposed material on catalog cuts by a reproducible means (highlighter pen does not transfer to copies). Ensure material lists contain material description, brand name, manufacturer's address and telephone number, stock number, size, identifying trademark or symbol, and other appropriate ratings. For submittals showing a variety of models and parts available from the manufacturer, clearly identify by circles, marking our other means the specific materials for which approval is requested.

Allocate 40 consecutive calendar days for the Department to review and respond to a submittal. Do not deviate from what is approved without approval by the Department. Do not fabricate or order material until receipt of the Department's approval. All submittals will be returned as either "Approved (as submitted)", "Approved as Noted" or "Rejected." The Contractor may proceed with fabrication or ordering for items marked "Approved." If an item is marked "Approved as Noted" without any stipulation for resubmittal, then the Contractor may proceed with fabrication or ordering. For any other notations, the Contractor shall revise the submittal, address comments and resubmit for approval.

43.3. DOCUMENTATION

A. General

Provide all manuals and plan of record (i.e., "as-built") documentation. All as-built plans and documentation shall be reviewed and accepted by the Engineer prior to final acceptance of the project. All documentation, except as otherwise specifically approved by the Engineer, must meet the following requirements:

1. Provide final as-built plans on 11" x 17" paper along with a PDF of each as-built plan sheet. Provide draft as-built plans for Department review on 22" x 34" paper. No documentation for as-built plans smaller than 11" x 17" will be accepted.
2. Provide any documentation that exceeds the size of 11" x 17" paper in a reproducible format 22" x 34" in size.

◆ **Revision No. 1, April 10, 2017 - This document supersedes version originally issued and sealed by J. Todd Brooks, NCPE No. 017586 on 12/28/2016**

U-4715B**ITS-324****Buncombe County**

3. For electrical schematics and cabinet wiring diagrams not bound into printed manuals, provide paper copies at least 22" x 34" in size.
4. No non-plan documentation smaller than 8.5" x 11" will be accepted.
5. Do not fold or crease reproducibles.

As a minimum, provide the documentation described in the paragraphs below.

B. Plan of Record Documentation

Provide as-built drawings that depict any changes of components, measurement or layout of the Plans. Show all construction changes, with the final location and depth of conduits, wiring external to the cabinet, locations of splice closures, system detector locations, and SMFO cable splicing and terminations, etc., in detail in a reproducible format. Submit as-built construction changes within 10 consecutive calendar days after the Observation Period begins. Note and date each change on the drawings. Failure to revise as-built documentation to reflect current work may result in withholding of payments until the as-built documentation is brought current. The submitted as-built documentation may be field-checked by the Engineer at his discretion. If the as-built documentation is found to have an unacceptable number of inaccuracies, the Engineer may withhold payment until the as-built plans are corrected. Include all field installation including the SMFO cable network installed on the drawings.

For underground conduit systems that house communications cable, furnish the Engineer with a plan of record drawing detailing the locations of the conduit system, including junction boxes and their corresponding GPS coordinates. For directionally-drilled underground conduit systems, identify the vertical location (i.e., depth) of the conduits along the run.

Store documentation for signal installations in a manila envelope placed in a weatherproof holder inside the cabinet drawer. Store all documentation furnished with the controllers and cabinets, including manuals, electrical schematic diagram, and cabinet wiring diagram inside the envelope in the weatherproof holder. Provide two marked-up "redline" copies of the signal plan and the electrical and programming detail, placing one copy in the weatherproof holder inside the cabinet drawer immediately upon installation of the cabinet and giving the second copy to the Engineer.

For CCTV camera assemblies, provide two copies of a parts list(s) that includes serial and model numbers of all Contractor-furnished equipment prior to final acceptance. All equipment and appurtenances shall be identified by name, model number, serial number, technical support and warranty telephone numbers, and any other pertinent information required to facilitate equipment maintenance.

The Department will provide the Contractor one electronic copy of the Plans for his use in developing the as-built drawings. Modify the original electronic file such that all changes are marked with callout boxes or other method approved by the Engineer. Any other base maps that may be necessary for the Contractor to prepare the as-built drawings in accordance with these Project Special Provisions will be the Contractor's responsibility. Use CADD conventions that are consistent with those used on the original plans.

Within 10 consecutive calendar days after the Observation Period begins, furnish one reproducible copy of the draft as-built plans in hard copy format for review. Provide draft hard copy as-built drawings on 22"x 34" bond plan sheets.

◆ **Revision No. 1, April 10, 2017 - This document supersedes version originally issued and sealed by J. Todd Brooks, NCPE No. 017586 on 12/28/2016**

U-4715B**ITS-325****Buncombe County**

Upon receipt of review comments from the Engineer, correct any errors and make all necessary revisions to the draft as-built plans prior to final acceptance of the project. Submit final as-built plans in electronic and hard copy format. Provide final hard copy as-built drawings on 11"x 17" bond plan sheets. Provide electronic plans in MicroStation (latest release in use by the Department) format along with copies of the same files saved/exported in AutoCAD format (for City use). Provide the electronic files on CD or DVD.

C. Manuals

Provide at least five hard copies along with one electronic copy (on CD or DVD) of the following manuals:

- Operator's manuals containing detailed operating instructions for each different type or model of equipment. Ensure that manuals contain instructions for possible modification to equipment.
- Maintenance procedures manuals containing detailed preventative and corrective maintenance procedures and troubleshooting procedures for each different type of model of equipment.
- Installation, operations and training manuals for all Contractor-provided software.

The manuals provided above shall be in addition to manuals provided with and stored inside each control equipment cabinet.

D. Wiring Diagrams

Provide detailed wiring diagrams that include interconnection (wired and wireless) of equipment with pin-out configurations, pin functions, and cable parts numbers. This includes configuration at each field equipment cabinet or equipment cabinet at central locations. Provide two copies of system connection diagrams showing system interconnection cables and associated terminations. Use naming convention approved by the Engineer and conforming to Belcore standards. Provide one electronic copy of the wiring diagrams in MicroStation format.

Example:

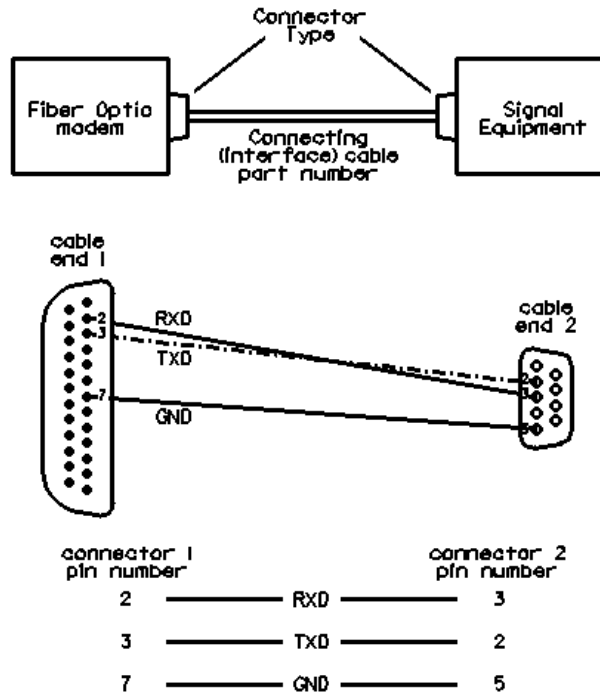

E. Splice Diagrams

Prepare as-built splice diagrams that depict the communications cable plant as constructed. Depict the splices made at each splice enclosure by identifying spliced fiber and buffer tube. Ensure the splice diagram is in a similar format to those provided with the project plans. Identify all expressed fibers, spare fibers, used fibers and capped fibers.

Original splice diagrams will be provided in electronic format in MicroStation format. Designate any changes to these diagrams by using a method approved by the Engineer. Furnish as-built splice diagrams in MicroStation format along with copies of the same files saved/exported in AutoCAD format (for City use). Provide the electronic files on CD or DVD.

Provide digital photographs of each fiber-optic splice. Include the splice number in the filename for each digital photo. Organize the photos in a logical folder structure and deliver them on CDs, DVDs or USB jump drive.

43.4. MEASUREMENT AND PAYMENT

There will be no direct payment for work covered in this section. Payment at the contract unit prices for the various items in the contract will be full compensation for all work covered by this section.

44. SYSTEM SUPPORT AND TEST EQUIPMENT

44.1. DESCRIPTION

Furnish fiber-optic system support and test equipment and signal system support and test equipment with all necessary hardware in accordance with the Plans and Project Special Provisions.

44.2. MATERIALS

A. General

Furnish equipment with test probes/leads, batteries (for battery-operated units), line cords (for AC-operated units), and carrying cases. Provide operating instructions and maintenance manuals with each item.

Before starting any system testing or training, furnish all fiber-optic communications system support and test equipment as well as signal system support and test equipment.

B. Fiber-Optic Restoration Kit

Furnish a fully functional fiber-optic restoration kit consisting of the following items (minimum):

- Pliers-type strippers,
- Non-nicking fiber stripper tool with procedures,
- Buffer tube stripper tool with procedures,
- Fiber-optic cleaver with diamond blade and average cut less than 0.5 degrees from perpendicular,
- Screw driver set,
- Fiber-optic cable for cleaning alignment sleeves and LC connectors and jumper ends,
- Fifty 2.5 mm swabs,
- Twenty-four 2.5 mm cleaning tips for cleaning and LC connectors, ferrules, and termin faces,
- Two rolls of electrical tape, 3/4-inch width,
- Laboratory type cleaning wipes,
- Metal ruler,
- Tweezers,
- Crimping pliers,
- Mechanical splice assembly manual,
- Mechanical splice assembly fixture,
- 12 non-adhesive, mechanical splices,
- Scissors,
- Hard-sided, padded storage case.
- Premises Service Kit includes tool frame, RJ-11/12 and RJ-45/CATV "F" die sets, round cable cutter/stripper, LC CST coax stripper, punch down tool with 110 and 66 blades, LAN & Telecom Cable Testing Kit, coax and data tester, plier type cutter/strippers, RJ-45 adapter and 2 BNC to CATV adapters.

◆ **Revision No. 1, April 10, 2017 - This document supersedes version originally issued and sealed by J. Todd Brooks, NCPE No. 017586 on 12/28/2016**

U-4715B**ITS-328****Buncombe County**

- 2 Mechanical Splice Trays with 12 mechanical splice capacity, compatible with the interconnect centers being installed in the traffic signal controller cabinets and CCTV cabinets.

C. Spare Cable and Connectors Kit

Furnish a minimum of 10 of each type of fiber-optic jumper of each length and each type of connector combination used on the project. In addition, furnish the following:

- 500 feet of outdoor-rated, UV-resistant Category 6 cable,
- 500 feet LMR-400 antenna cable,
- 100 feet LMR-600 antenna cable,
- N-type male radio connectors,
- 20 Category 6 patch cords, 5 feet long with molded strain relief cables, and
- 20 RJ-45 male connectors.

D. Fiber-Optic Power Meter

Furnish two fiber-optic power meters for measuring absolute power and link losses, as well as monitoring power levels and testing threshold levels. Provide the following features:

- Spectral range: 750 nm to 1700 nm,
- Calibrated wavelengths: 850, 1310, and 1550 nm,
- Accuracy: ± 3 percent (± 0.1 dB) at -20 dBm at 70 degrees F at calibrated wavelengths,
- Readout resolution: 4 digits, 0.01 dBm,
- Display: Backlit LCD,
- Fiber-optic connector: LC, SC and ST,
- Power-up stabilization: Less than five seconds at ambient temperature,
- Tone threshold settings: User selectable from 1 to 35 dB, plus OFF,
- Analog output port:
 - Voltage: 0 to +1 V FSD of linear power range,
 - Output impedance: 5 kilohms, nominal,
- Temperature:
 - Operating: 32° to 122° F,
 - Storage: 0° to 150° F,
- Relative humidity: 5 to 95 percent, non-condensing,
- Battery power: Alkaline: 28 hours; NiCad: 8 hours (recharger and NiCad batteries provided)
- Carrying case

E. Optical Light Generator

Furnish four optical light generators for testing link losses and trouble-shooting single-mode fiber-optic cables and networks. Provide a lightweight, compact, handheld unit constructed of rugged, durable materials. Provide a unit with automatic wavelength detection mode and the following additional features:

- Emitter type: Class I laser
- Spectral width: 5 nm or less,
- Nominal wavelengths: 1310 and 1550 nm,

◆ **Revision No. 1, April 10, 2017 - This document supersedes version originally issued and sealed by J. Todd Brooks, NCPE No. 017586 on 12/28/2016**

U-4715B**ITS-329****Buncombe County**

- Warm-up period: 15 minutes or less
- Display: Backlit LCD,
- Fiber-optic connector: LC, SC and ST
- Power/signal stability: ± 0.10 dB,
- Modulation: 270, 1k, 2k Hz,
- Weight with batteries: 1.2 lb. max.
- Temperature (minimum range):
 - Storage: 32° to 122° F
 - Operating: -10° to 150° F,
- Relative humidity: 0% to 95% non-condensing,
- Batteries: Alkaline: 28 hours; NiCad: 8 hours (recharger and NiCad batteries provided)
- Carrying case.

F. Visual Fault Locator

Furnish two lightweight, compact, handheld, battery-powered visual fault locators (VFL) designed for visually locating faults in single-mode fiber-optic cables, jumpers, pigtails and patch panels, such as microbends, breaks, bare fibers, poor connectorization and poor splicing. Provide a unit with a red laser light source that when coupled with an optical fiber will identify a fault in the optical path by emitting light (e.g., producing a glow) at the point of the fault. Provide a unit constructed of rugged, durable materials and which has a dust cap tethered to the unit to protect the optic interface when not in use. Provide batteries of the required size and quantity and a carrying case or protective belt holster with each visual fault locator. Provide the following additional features:

- Emitter Type: Class II Visible Red Laser
- Wavelength: 635 - 670 nm
- Peak Output Power: 1mW
- Selectable Output Modes: Continuous (steady; constant-on) and pulsed (flashing; blinking) at 2-3 Hz frequency
- Batteries: No more than two AA or two AAA (alkaline)
- Battery Life: Minimum of 30 hours of continuous operation in continuous mode
- Connector Interface: 2.5mm ferrule connector, Type LC, SC or ST
- Weight with Batteries: 5.7 oz. (180 g) maximum
- Operating Temperature (min. range): 14°F to 113°F (-10°C to +45°C)
- Storage Temperature (min. range): -4°F to 140°F (-20°C to +60°C)

G. Conflict Monitor Tester with Notebook Computer

Furnish two (one of the Department and one for the City) standalone, portable conflict monitor test units with notebook computers intended for use on workbench. The tester shall use/control an Intel-based notebook computer of equal requirements to other notebook computers furnished under this project for input/output. The tester shall test conflict monitor displays, timing and voltage functions, and input/output combinations of either true or false conflicts. Any software provided with the tester shall be modular, menu driven, and offer a "help" screen. A video "setup/usage" training tape or DVD shall be provided with each unit. All input/outputs shall be in plain English. It shall be possible to generate a hardcopy printout,

◆ **Revision No. 1, April 10, 2017 - This document supersedes version originally issued and sealed by J. Todd Brooks, NCPE No. 017586 on 12/28/2016**

or to store the results electronically to a disc file. A “No Faults Detected” indication shall be displayed as appropriate.

H. Ethernet Radio Support Equipment

1. Ethernet Radio

Furnish two 900 MHz Ethernet radios identical to the type installed in the traffic signal controller and one 2.4 GHz Ethernet radio for CCTV cabinets to be used for emergency restoration of the system and the wireless communications system. In addition, furnish two Ethernet radio lightning arrestors identical to each type installed in the traffic signal controller and CCTV cabinets to be used for emergency restoration of the transient voltage suppression equipment.

I. Test Controllers with Cabinets

Furnish and install a Model 2070E controller with a Type 332A test cabinet at the TMC. The test cabinet shall include a full complement of detector cards, switch packs, a conflict monitor, two (2) AC isolators, two (2) DC isolators and a railroad preemption test panel. Provide a railroad preemption panel that is identical to those installed at railroad preemption locations in the field under this contract. Fully label the test cabinet and panels. Equip the Type 332A test cabinet with an auxiliary output file to simulate flashing yellow arrow phasing. Provide controllers and cabinets that comply with the material requirements for controllers and cabinets in preceding subsections of this Project Special Provision. Fully label each test cabinet. Plug the power cord from the test cabinet into an existing wall receptacle adjacent to the cabinet.

1. Construction

Furnish each test cabinet with a heavy-duty aluminum dolly base with heavy-duty, locking casters. The base shall accommodate a fully equipped, base-mounted cabinet. Attach a pole or pedestal to each base to support a display panel, which shall be located beside the cabinet for convenient use by maintenance personnel. The display panel shall have all indicators and switches on the front and shall have a suitable aluminum enclosure. The panel shall be fully labeled.

2. Indicators

The panel shall contain indicators to display the outputs of all the cabinet's traffic signal load switched. Red, yellow and green indicators shall be used to display the outputs of the traffic signal load switches. In addition, indicators shall be provided for four (4) pedestrian signal displays and 4 special functions. The indicators shall use LED's that are user replaceable.

3. Controls

Equip the display panel with controls that are connected to simulate all the inputs, for test purposes, to the controller which are not already accommodated by switches in the controller cabinet.

4. Harnesses

Connect the display panel to the controller cabinet by means of harnesses. Conceal the harnesses inside the pedestal or pipe supporting the panel and route the harnesses into the test cabinet through the bottom of the cabinet.

U-4715B

ITS-331

Buncombe County

5. Connection to the System

Furnish and install Ethernet cables to connect the test controllers and their corresponding conflict monitors to the Ethernet switch at their respective locations.

J. CCTV Test Cabinet

Furnish and install a Type 336A CCTV test cabinet in the TMC. The test cabinet shall include a Type 336A cabinet be configured identically as installed at field locations under this project. The test cabinet shall include a complete CCTV camera with enclosure and built-in encoder, CCTV test panel, and all cabling necessary to integrate the camera and all cabinet equipment. The test cabinet and panel shall be fully labeled. Wire the CCTV to the cabinet.

Integrate the CCTV test cabinet with a CCTV assembly furnished under the "CCTV Field Equipment" section of these Project Special Provisions.

1. Construction

Mount the Type 336A CCTV test cabinet on a heavy-duty aluminum dolly base with four (4) heavy duty locking casters. The base shall accommodate a fully equipped base-mounted CCTV cabinet. A pole or pedestal shall be attached to the base to support a CCTV camera, which shall be located beside the cabinet convenient for use by maintenance personnel.

2. Connection to System

Furnish and install Ethernet cables to connect the CCTV test cabinet to the Ethernet core switch in the TMC.

44.3. MEASUREMENT AND PAYMENT

Furnish fiber-optic restoration kit will be measured and paid as the actual number of fiber-optic restoration kits furnished and accepted.

Furnish spare cable and connectors kit will be measured and paid as the actual number of spare cable and connectors kits furnished and accepted.

Furnish fiber-optic power meter will be measured and paid as the actual number of fiber-optic power meters furnished and accepted.

Furnish optical light generator will be measured and paid as the actual number of optical light generators furnished and accepted.

Furnish visual fault locator will be measured and paid as the actual number of visual fault locators furnished and accepted.

Furnish video monitor will be measured and paid as the actual number of video test monitors furnished and accepted.

Furnish conflict monitor tester will be measured and paid as the actual number of conflict monitor testers with notebook computers furnished and accepted. There will be no separate measurement and payment for the notebook computer as it will be considered incidental to furnishing the conflict monitor tester.

Furnish detector card (Model 222) will be measured and paid as the actual number of Type 222 detector cards furnished and accepted.

◆ **Revision No. 1, April 10, 2017 - This document supersedes version originally issued and sealed by J. Todd Brooks, NCPE No. 017586 on 12/28/2016**

U-4715B**ITS-332****Buncombe County**

Furnish 2070E controller will be measured and paid as the actual number of 2070E controllers furnished and accepted.

Furnish _____ cabinet will be measured and paid as the actual number of each type of controller cabinet furnished and accepted.

Furnish 2018 enhanced conflict monitor will be measured and paid as the actual number of Model 2018 enhanced conflict monitors furnished and accepted.

Furnish Ethernet edge switch will be measured and paid as the actual number of Ethernet edge switches furnished and accepted.

Furnish 2.4 GHz Ethernet radio will be measured and paid as the actual number of 2.4 GHz Ethernet radios furnished and accepted. This item includes one complete spare Ethernet radio and ancillary components as specific within. This item includes one spare antenna of each type used on the project, lightning arrestor, coaxial cable shield grounding system with weatherproofing, power supply and power cord per radio.

Furnish 900 MHz Ethernet radio will be measured and paid as the actual number of 900 MHz Ethernet radios furnished and accepted. This item includes one spare antenna of each type used on the project, lightning arrestor, coaxial cable shield grounding system with weatherproofing, power supply and power cord per radio.

Furnish CCTV camera assembly will be measured and paid as the actual number of CCTV camera assemblies furnished and accepted.

Furnish CCTV cabinet will be measured and paid as the actual number of CCTV cabinets furnished and accepted.

Test controller with cabinet will be measured and paid as the actual number of 2070E controllers with a 332 test cabinet furnished, installed in the TMC and accepted.

Test cabinets and controllers will not be included in the numbers of spare cabinets and controllers provided for this project.

No measurement will be made of load switches, AC isolator cards, DC isolator cards, detector cards, preemption panels, and auxiliary output files provide with the test controllers and test cabinets as they will be considered incidental to furnishing and installing the test controllers with cabinets. No measurement will be made of Ethernet cables required to connect the test controller and conflict monitor to an Ethernet switch and the power cord required to plug the test cabinet into the existing wall receptacle as they will be considered incidental to furnishing and installing the test controllers with cabinets.

CCTV test cabinet with CCTV camera assembly will be measured and paid as the actual number of 336A CCTV test cabinets with CCTV camera assembly furnished, installed and accepted in the TMC. No measurement will be made of the camera assembly nor for the Ethernet cables required to connect the CCTV test cabinet to the Ethernet core switch and the power cord required to plug the test cabinet into the existing wall receptacle as they will be considered incidental to furnishing and installing the CCTV test cabinet.

◆ **Revision No. 1, April 10, 2017 - This document supersedes version originally issued and sealed by J. Todd Brooks, NCPE No. 017586 on 12/28/2016**

U-4715B**ITS-333****Buncombe County**

Payment will be made under:

| Pay Item | Pay Unit |
|--|-----------------|
| Furnish Fiber-Optic Restoration Kit | Each |
| Furnish Spare Cable and Connectors Kit | Each |
| Furnish Fiber-Optic Power Meter | Each |
| Furnish Optical Light Generator | Each |
| Furnish Visual Fault Locator | Each |
| Furnish Video Monitor | Each |
| Furnish Conflict Monitor Tester | Each |
| Furnish Detector Card (Model 222) | Each |
| Furnish 2070E Controller | Each |
| Furnish 336S Cabinet | Each |
| Furnish 332 Cabinet | Each |
| Furnish 2018 Enhanced Conflict Monitor | Each |
| Furnish Ethernet Edge Switch | Each |
| Furnish 2.4 GHz Ethernet Radio | Each |
| Furnish 900 MHz Ethernet Radio | Each |
| Furnish CCTV Camera Assembly | Each |
| Furnish CCTV Cabinet | Each |
| Test Controller with Cabinet | Each |
| CCTV Test Cabinet | Each |

◆ **Revision No. 1, April 10, 2017 - This document supersedes version originally issued and sealed by J. Todd Brooks, NCPE No. 017586 on 12/28/2016**

45. TRAINING

45.1. DESCRIPTION

Provide training for the installation, operation and maintenance of:

- Ethernet core switch,
- Ethernet edge switches,
- ITS Servers,
- Network configuration,
- Fiber-optic communications cable,
 - Fiber-optic interconnect centers,
 - Splice enclosures (aerial and underground)
 - Splice trays and other related fiber-optic equipment in accordance with the Plans and Project Special Provisions,
- Wireless communications equipment
- CCTV field equipment,
- Video monitors,
- Signal system software,
- Controller hardware and local controller software including:
 - 2070E Controllers,
 - Cabinets,
 - Conflict monitors,
 - Detectors,
 - OASIS[®] IP (Version) controller software,
- Integrated Pushbutton Accessible Pedestrian Signals
- UPS, and
- System support and test equipment.

45.2. MATERIALS

A. General

Provide training in the installation, operation, maintenance, troubleshooting and repair of all equipment and software. Prepare training outline, agenda, training manuals, training exercises, instructor resumes and any other teaching aids and submit them for approval by the Department prior to conducting training. For each course, provide a training exercise to demonstrate through hands-on activities the subject matter covered in the course lecture or course section. For exercises requiring computers, furnish enough computers to have one computer per two students.

Provide all laptop computers, projectors and projector screens needed for the training. Provide all audiovisual equipment needed for presentations and demonstrations, including video players. Provide new test cabinets, controllers and conflict monitors for use during the training. Furnish all power cords, extension cords, power strips and other cables required for the equipment used in the training.

Provide draft-training material to the Department for review and approval at least 60 days prior to the scheduled training. Provide adequate time for review and revision of the draft

◆ **Revision No. 1, April 10, 2017 - This document supersedes version originally issued and sealed by J. Todd Brooks, NCPE No. 017586 on 12/28/2016**

U-4715B

ITS-335

Buncombe County

training materials. Furnish all audio-visual equipment, demonstration equipment, including a test cabinet, and "hands-on" equipment in support of the envisioned training. Each training participant shall receive a copy of course materials including both comprehensive and presentation manuals. Assume there will be a maximum of 16 students in each class session. Provide two additional copies of these documents to the Department.

Utilize training personnel well versed in the subject matter and with extensive field experience dealing with real world problems. Utilize training personnel that have been certified by the respective manufacturers.

The Department will provide the training facility. Provide the Department with a 30-day notification to carry out the training so that arrangements can be made for attendance. Coordinate a mutually agreeable date, time and location with the Division 13 staff and City staff through the Engineer. The Engineer shall approve the training schedule time and location. A "day" of training shall consist of 8 hours of training.

When two sessions are required, conduct the first session early in the project, scheduling it to occur immediately prior to the first implementation of the given software or hardware so that City and Department staff can become familiar with the software or hardware prior to its implementation on the project. Conduct the second session near the conclusion of the project. If more than two sessions are required, conduct the remaining sessions approximately midway between the first and last sessions. Do not conduct multiple sessions back-to-back or near end of project. **Conduct the first session of training on 2070 traffic signal controllers, cabinets, conflict monitors and controller firmware at least one week prior to installing the first new controller with cabinet on the project.**

Develop the course content specifically for the products supplied for this project. The course shall include the following topics:

- Introductory-level briefing to familiarize attendees;
- Terminology;
- Theory of operation;
- Installation;
- Hardware and software configuration;
- Operating procedures and capabilities;
- Testing, diagnostics and troubleshooting;
- Software applications;
- Use of the system documentation to operate, diagnose, maintain, and expand the system; and
- "Hands-on" use of the system, laptop computer and software, system test equipment, and any other system equipment supplied.

◆ **Revision No. 1, April 10, 2017 - This document supersedes version originally issued and sealed by J. Todd Brooks, NCPE No. 017586 on 12/28/2016**

U-4715B

ITS-336

Buncombe County

Provide course lengths as follows:

| Course | Type of Training | Total Students | No. of Sessions | Length (Days) |
|---|--------------------------------|----------------|-----------------|---------------|
| Ethernet Communications and Networking* | Lecture and Hands-on Exercises | 16 | 2 | 5 |
| Fiber-Optic Communications | Lecture and Hands-on Exercises | 16 | 2 | 3 |
| CCTV Field Equipment | Lecture and Hands-on Exercises | 16 | 1 | 1 |
| Wireless Communications Equipment | Lecture and Hands-on Exercises | 16 | 1 | 2 |
| Digital Video Equipment | Lecture and Hands-on Exercises | 16 | 1 | 0.5 |
| Signal System Software | | 16 | 2 | 4 |
| 2070 Traffic Signal Controllers, Conflict Monitors, Cabinets, and Controller Firmware | Lecture and Hands-on Exercises | 16 | 3 | 5 |
| UPS | Lecture and Demonstration | 16 | 1 | 0.25 |

* Do not conduct any training on this topic until the System Design Report has been submitted for review and subsequently approved by the Department.

Provide additional specific training as described below.

B. Ethernet Communications and Networking

Provide training using the test and repair equipment furnished for the project. The training session shall be presented by field service specialist(s) employed by the suppliers of the communications system components. Provide training for the Ethernet communications and networking for the following categories and for the minimum number of hours shown:

| Course | Type of Training | Length (Days) |
|---|-------------------------------------|---------------|
| Ethernet Communications and Networks | | 2 |
| Terminology | Lecture | |
| Theory of design | Lecture | |
| Network configuration | Lecture | |
| VLANs | Lecture | |
| Equipment overview | Lecture | |
| Network maintenance | Lecture, Demonstration and Hands-on | |
| System backup, data archiving, routine procedures | Hands-on | |
| Troubleshooting procedures | Hands-on | |
| Testing | Hands-on | |
| System restart and recovery | Hands-on | |
| Question and answer session | Lecture | |

◆ **Revision No. 1, April 10, 2017 - This document supersedes version originally issued and sealed by J. Todd Brooks, NCPE No. 017586 on 12/28/2016**

U-4715B

ITS-337

Buncombe County

| Course | Type of Training | Length (Days) |
|---|-------------------------------------|---------------|
| Ethernet Switches (all types and configurations) | | 2 |
| Introduction | Lecture | |
| Configuration and programming | Lecture and Hands-on | |
| Review of Maintenance Manual | Lecture and Hands-on | |
| Review of Operations Manual | Lecture and Hands-on | |
| Maintenance | Lecture, Demonstration and Hands-on | |
| Routine | Hands-on | |
| Troubleshooting procedures | Hands-on | |
| Testing | Hands-on | |
| System restart and recovery | Hands-on | |
| Question and answer session | Lecture | |
| Network Management Software | | 1 |
| Introduction | Lecture | |
| Network Configuration (changes in network only) | Lecture and Hands-on | |
| Question and answer session. | Lecture | |

◆ **Revision No. 1, April 10, 2017 - This document supersedes version originally issued and sealed by J. Todd Brooks, NCPE No. 017586 on 12/28/2016**

U-4715B

ITS-338

Buncombe County

C. Fiber-Optic Cable

Provide training using the test and repair equipment furnished for the project. Provide training for the fiber-optic system for the following categories and for the minimum number of hours shown:

| Course | Type of Training | Length (Days) |
|--|-------------------------------------|---------------|
| Ethernet Switches – Optics | | 1 |
| Safety | Lecture | |
| Introduction to Ethernet switch optics | Lecture | |
| Review of Maintenance Manual – optics | Lecture | |
| Review of Operations Manual – optics | Lecture | |
| Question and answer session | Lecture | |
| Fiber-Optic Cable System | | 2 |
| Safety | Lecture | |
| Introduction to fiber-optics, theory, and principles | Lecture | |
| Fiber and cable types | Lecture and Hands-on | |
| National Electrical Code considerations | Lecture and Hands-on | |
| Plenum and riser type cable | | |
| Outdoor cable, etc. | | |
| Introduction to terminating hardware, end equipment, and applications | Lecture, Demonstration and Hands-on | |
| Connectors (ST, SC, LC, etc.) | | |
| Splice enclosure, splice trays, and connector panels | | |
| Cable placement techniques | | |
| Question and answer session | | |
| Cable handling and preparation (sheath removal, grip installation, etc.) | Lecture, Demonstration and Hands-on | |
| Splicing and terminating methods | Lecture, Demonstration and Hands-on | |
| Mechanical splicing using various techniques | | |
| Fusion splicing | | |
| Field termination of connector types | | |
| Introduction to cable plant testing procedures | Lecture, Demonstration and Hands-on | |
| Proper usage of optical light generator and power meter | | |
| Class project (build working system using cables/connectors made by attendees) | Lecture, Demonstration and Hands-on | |
| Question and answer session. | | |
| Class project -- Testing and troubleshooting | Lecture, Demonstration and Hands-on | |
| Cable system maintenance and restoration | Lecture | |
| Question and answer session. | | |

◆ **Revision No. 1, April 10, 2017 - This document supersedes version originally issued and sealed by J. Todd Brooks, NCPE No. 017586 on 12/28/2016**

U-4715B

ITS-339

Buncombe County

D. CCTV Field Equipment

Provide training that includes operational theory and procedures of the field components of the CCTV system. This training shall be oriented towards the users and maintenance personnel of the system. The training session shall be presented by field service specialist(s) employed by the suppliers of the CCTV field components. This training session shall include exercises that should take one-half of the day. Provide training for the CCTV field equipment and the local CCTV camera software as described below:

| Course | Type of Training | Length (Days) |
|--------------------------|-------------------------------------|---------------|
| Operations | Lecture | 0.5 |
| Theory of operation | Lecture, Demonstration | |
| Local camera programming | Lecture, Demonstration and Hands-on | |
| Camera addresses | | |
| Presets | | |
| Privacy zones | | |
| Tours | | |
| Other features | | |
| Maintenance | Lecture | 0.5 |
| Routine maintenance | Lecture, Demonstration and Hands-on | |
| Testing | Lecture, Demonstration and Hands-on | |
| Troubleshooting | Lecture, Demonstration and Hands-on | |

E. Digital Video Equipment

Provide training that includes operational theory and procedures of the central components of the CCTV system. This training shall be oriented towards users and maintenance personnel of the system. This training session shall include hands-on exercises that should take approximately one-half of the session. The training shall address the use of, but not limited to, the following devices: NVR, encoders, software decoder, monitors, and the video server. Provide training for the digital video equipment as described below:

| Course | Type of Training | Length (Days) |
|-------------------------------------|-------------------------------------|---------------|
| Operations and Theory of operations | Lecture | 0.25 |
| Programming | Lecture, Demonstration and Hands-on | 0.25 |
| Maintenance | Lecture | |
| Routine maintenance | Lecture, Demonstration and Hands-on | |
| Testing | Lecture, Demonstration and Hands-on | |
| Troubleshooting | Lecture, Demonstration and Hands-on | |

◆ **Revision No. 1, April 10, 2017 - This document supersedes version originally issued and sealed by J. Todd Brooks, NCPE No. 017586 on 12/28/2016**

U-4715B

ITS-340

Buncombe County

F. Signal System Software

Provide training that includes operational theory and procedures of the signal system software. This training shall be oriented towards users and maintenance personnel of the system. This training shall include hands-on exercises that should take approximately one-half of the total session. The training session shall be presented by field service specialist(s) employed by the suppliers of the signal system software. Provide training for the signal system central software as described below:

| Course | Type of Training | Length (Days) |
|---|-------------------------------------|---------------|
| Part 1 | Lecture & Demonstration | 1 |
| Overview of Part 1 | | |
| Time-of-day operation and event scheduling | | |
| Traffic responsive pattern selection algorithms | | |
| Reporting Capabilities | Lecture, Demonstration and Hands-on | |
| Interactive database manipulation | | |
| Theory and application of traffic responsive operations | | |
| Special functions | | |
| Part 2 | Lecture and Hands-on | 1 |
| Review of Part 1/Overview of Part 2 | | |
| System operations and recommended procedures | | |
| Part 3 | Lecture, Demonstration and Hands-on | 2 |
| Review of Parts 1 & 2/Overview of Part 3 | | |
| Development and modification of system graphics | | |
| Preparation of dynamically functioning graphics | | |

G. 2070 Controllers, Conflict Monitors, Cabinets and Controller Firmware

Provide three identical training sessions in the basic theory, operation, routine maintenance and troubleshooting of the 2070 controller equipment, cabinets, conflict monitors, auxiliary output files and other related equipment. **Conduct one of these training sessions prior to the installation of any new controllers and cabinet on the project.** Assume the attendees have no working knowledge through their current use of 2070 controllers.

Provide training, both lecture (i.e., classroom instruction) and hands-on exercise in the use of the local controller firmware, including how to load the firmware onto a new controller. Provide one computer for every two students for the hands-on exercises.

Training for controllers and cabinets shall be integrated into a single session with training exercises for cabinets and training exercises for controllers running concurrently. Instructors from the controller Vendor and instructors from the cabinet Vendor shall be in attendance during all days of the session.

◆ **Revision No. 1, April 10, 2017 - This document supersedes version originally issued and sealed by J. Todd Brooks, NCPE No. 017586 on 12/28/2016**

U-4715B**ITS-341****Buncombe County**

Controller-specific instruction during the session shall be taught by experienced Vendor personnel who thoroughly understand both the traffic engineering aspects of signal timing and the entry of timing into the controller and internal TBC's. Cabinet-specific instruction during the session shall be taught by a field service specialist(s) employed by the manufacturer.

The signal controller and cabinet assemblies session shall include, but not be limited to, the following:

- Formal classroom presentation of the functional operation of the signal cabinet, including a discussion on each individual component of the cabinet that details its function, installation techniques, and normal operation.
- Formal classroom presentation of the functional operation of the 2070E controller.
- Formal classroom presentation of proper cabinet wiring procedures.
- Hands-on workshop on installation of electrical components and surge protection for cabinets.
- Formal classroom presentation and hands-on workshop on operation of signal monitor tester.
- Hands-on workshop on timing data entry for 2070E controller.
- All local intersection timing parameters.
- All coordination timing parameters.
- All parameters and threshold levels associated with traffic responsive operation.
- Formal classroom presentation and hands-on workshop on operation of local controller utility software.
- Formal classroom presentation and hands-on workshop on operation of controller tester.
- Hands-on workshop of proper installation, programming, and troubleshooting of conflict monitors.
- Hands-on workshop of proper installation, programming, and troubleshooting of detector cards and lead-in cable.
- Hands-on workshop wherein maintenance personnel will troubleshoot simulated controller and cabinet assembly faults to the component level.

◆ **Revision No. 1, April 10, 2017 - *This document supersedes version originally issued and sealed by J. Todd Brooks, NCPE No. 017586 on 12/28/2016***

U-4715B

ITS-342

Buncombe County

The lecture, demonstration; hands-on class shall include the following sessions specific to the 2070 related family of hardware and software (controllers, cabinets, signal monitors and detectors):

| Course | Type of Training | Length (Days) |
|--------------------------------|-------------------------------------|---------------|
| Programming | Lecture, Demonstration and Hands-on | 1.5 |
| Phasing, | | |
| Timing, | | |
| Preemption, | | |
| Coordination, Data transfer | | |
| Operations | Lecture | 1.5 |
| Theory of operation | Lecture, Demonstration and Hands-on | |
| Testing | Lecture, Demonstration and Hands-on | |
| Maintenance | Lecture | 2 |
| Routine maintenance | Lecture, Demonstration and Hands-on | |
| Troubleshooting | Lecture, Demonstration and Hands-on | |

Each of the identical training sessions shall consist of five consecutive days, beginning on a Monday.

H. Wireless Communications System

Provide training for the 900 MHz Ethernet radio and 2.4 GHz Ethernet bridge radio equipment as described below:

| Course | Type of Training | Length (Days) |
|--|-------------------------------------|---------------|
| Operations | Lecture, Demonstration | 2.0 |
| Theory of operation | Lecture | |
| Safety | Lecture | |
| Antenna alignment | Lecture | |
| Site Surveys | Lecture, Demonstration and Hands-on | |
| Procedures | | |
| Interpreting and understanding the results | | |
| Programming and software | Lecture, Demonstration and Hands-on | |
| Configuration | | |
| Repeater applications | | |
| Maintenance | Lecture | |
| Routine maintenance | Lecture, Demonstration and Hands-on | |
| Testing | Lecture, Demonstration and Hands-on | |
| Troubleshooting | Lecture, Demonstration and Hands-on | |

◆ **Revision No. 1, April 10, 2017 - This document supersedes version originally issued and sealed by J. Todd Brooks, NCPE No. 017586 on 12/28/2016**

U-4715B

ITS-343

Buncombe County

I. UPS

Provide training for the UPS units that is 2 hours in length, including both classroom and “hands-on” training.

45.3. MEASUREMENT AND PAYMENT

Training will be measured and paid at the contract lump sum price. The price and payment will be full compensation for all work required by this section of these Project Special Provisions.

Payment will be made under:

Pay Item

Pay Unit

Training

Lump Sum

46. TESTING AND ACCEPTANCE

46.1. GENERAL

Conduct and complete successfully the following progressive series of tests before acceptance: field demonstration test prior to installation, installed standalone tests, system test of the network hardware, network management software and an operational test. Develop a comprehensive series of test plans for each device to determine the equipment was correctly installed and meets the requirements of materials, workmanship, performance, and functionality required in the plans and project special provisions. The test plans shall describe the functions to be tested, purpose of test, setup requirements, procedures to be followed, any inputs and expected outputs for each test, criteria for pass/fail and any required tools or test equipment. Any software testers shall be pre-approved by the Department.

Develop as part of the Test Plan a Traceability Matrix of all the individual subsystem functional requirements to be used to cross-reference each planned test to a specific contract requirement to be verified. This Test Evaluation/Traceability Matrix shall be used by the Engineer to crosscheck the functional requirements and the results.

A key element of test plans, where appropriate, is the introduction of forced errors into the functional test. The test plan shall check the actual result of the forced error against the anticipated result. Tests will be performed by the Contractor and witnessed by the Department and the City. No deviation from the written test procedure shall be permitted without approval from the Engineer. Any changes to the approved test procedure to accommodate unforeseen events during the time of testing shall be documented in a copy of the master test procedure. Immediately following the conclusion of each test, the Department, the City and the Contractor shall meet to agree on the results observed and recorded during the testing. This will form the basis for the conclusions reported in the test plan. All test results, notes, and observations shall be maintained in both electronic and hard copy. Maintain complete records of all test results during all stages of testing.

46.2. INSTALLED SITE TESTS

Conduct an approved, standalone equipment installation test at the field site. Test all standalone functions of the field equipment using equipment installed as detailed in the plans, or as directed by the Engineer.

Complete approved test plan forms and turn them over to the Engineer for review as a basis for rejection or acceptance. Provide a minimum notice of 30 calendar days prior to all tests to permit the Engineer or his representative to observe each test.

If any unit fails to pass its stand-alone test, correct the unit or substitute another unit in its place, then repeat the test.

If a unit has been modified as a result of a standalone test failure, prepare a report describing the nature of the failure and the corrective action taken and deliver it to the Engineer prior to re-testing the unit. If a failure pattern develops, the Engineer may direct that design and construction modifications be made to all units without additional cost to the Department or an extension of the contract period.

◆ **Revision No. 1, April 10, 2017 - This document supersedes version originally issued and sealed by J. Todd Brooks, NCPE No. 017586 on 12/28/2016**

U-4715B**ITS-345****Buncombe County**

Utilize vendor supplied device software to perform diagnostic tests of each device. The vendor supplied diagnostic software shall be provided to the Department before final acceptance. Test the following features of each competent as described below.

A. Fiber-Optic Cable

Conduct optical time domain reflectometer (OTDR) tests on the cable on the reel and after the cable is installed and terminated. Provide written notification a minimum of ten days before beginning fiber-optic cable testing.

After splicing is completed, perform bi-directional OTDR tests on each fiber, including unused fibers, to ensure the following:

- Fusion splice loss does not exceed 0.05 dB,
- Terminations and connections have a loss of 0.5 dB or less, and
- Reflection loss is 40 dB or greater for each connector.

Install a 1000-foot pre-tested launch cable between the OTDR and fiber-optic cable to be tested.

If exceeded, remake splices until the loss falls below 0.05 dB. The Engineer will record each attempt for purposes of acceptance.

Test the fiber-optic cable at both 1310 and 1550 nm.

Furnish durable labeled plots and electronic copies on a CD or DVD of test results for each fiber including engineering calculations demonstrating that OTDR test results meet or exceed the attenuation requirements and that optical properties of the cable have not been impaired. Clearly label each OTDR trace identifying a starting and ending point for all fibers being tested.

Provide engineering calculations and tests for fiber-optic cable that demonstrate the loss budget where the fiber originates and where the fiber meets an electronic device. The calculations shall summarize the optical losses versus the allowable losses for the communications equipment between each pair of communications hardware. Provide a summary section or spreadsheet with a labeled tabular summary showing each test segment with begin and end points and actual versus allowable losses. Label the manufacturer's make, model number and software version of the OTDR used for testing.

Furnish one hard copy of each of the OTDR trace results and electronic copies of all trace results on a CD or DVD along with digital photographs of all splices.

If any fiber exceeds the maximum allowable attenuation or if the fiber-optic properties of the cable have been impaired, take approved corrective action including replacement of complete segments of fiber-optic cable if required. Corrective action will be at no additional cost to the Department.

B. Ethernet Communications System**1. TMC and City Hall Wiring**

Test any cable installed as part of this project per TIA 568 specifications for continuity, opens, shorts, split pairs, mis-wiring and reversed pairs. Test for DC resistance, impedance, and line capacitive loading. Correct any faults and retest. If retest fails, replace defective cable or connectors.

◆ **Revision No. 1, April 10, 2017 - This document supersedes version originally issued and sealed by J. Todd Brooks, NCPE No. 017586 on 12/28/2016**

2. ITS Servers, Workstations, and Laptop Computers

The following operational tests shall be performed for each ITS server, workstation, and laptop computer in accordance with the test plans. After the equipment has been installed:

- Connect all components (displays, mice, keyboards, printers, network cables, power supplies),
- Configure network communications,
- Map network drives,
- Test connections to all devices by pinging,
- Run diagnostic utilities on the hardware,
- Map all network servers, and
- Print test pages for each workstation on each printer to verify printer configuration.

3. Ethernet Switches

Once the Ethernet core switch and Ethernet edge switches have been installed, conduct local field acceptance tests of the Ethernet edge switch field site according to the submitted test plan. Perform the following:

- Verify that physical construction has been completed as detailed in the Plans,
- Inspect the quality and tightness of ground and surge protector connections,
- Verify proper voltages for all power supplies and related power circuits,
- Connect devices to the power sources,
- Verify all connections, including correct installation of communication and power cables, and
- Perform testing on multicast routing functionality.

Repair or replace defective or failed equipment and retest.

Upon satisfactory completion of operational test, begin an Observation Period of 60 days prior to system acceptance.

4. KVM Assembly

The following operational tests shall be performed for each KVM assembly in accordance with the test Plans. After the KVM assembly has been installed:

- Connect all servers, monitors, keyboards, mice, and power supplies,
- Program the on-screen display to assign ports and bank numbers and to enter the names of each server in the menu,
- Program the KVM switch for scan features, access privileges, and
- Select each server and ensure the mouse and keyboard work the selected server and the monitor displays the appropriate server.

C. Traffic Signal Controllers and Conflict Monitors

The following items, not otherwise required to be tested elsewhere, shall be tested: cable continuity, grounding, power-up self-test, proper controller sequencing, detector and pedestrian pushbutton calls.

U-4715B

ITS-347

Buncombe County

D. Communications System Support Equipment

Perform self-diagnostic tests on all electronic test equipment provided to the Department to ensure the equipment is proper operating order. Utilize the supplied test equipment in the training for the fiber-optic cable.

E. CCTV Field Equipment

Develop an operational test plan that demonstrates all requirements of the equipment and software. Submit for approval before conducting tests.

Notify the Department at least 14 calendar days prior to the proposed date for the tests. The Department and the City shall have the right to witness such tests, or to designate an individual or entity to witness such tests.

Perform the following local field operational tests at the camera assembly field site in accordance with the test Plans. A laptop computer shall provide camera control and positioning. After completing the installation of the camera assembly, including the camera hardware, power supply, and connecting cables, the Contractor shall:

- Furnish all equipment, appliances, and labor necessary to test the installed cable and to perform the following tests before any connections are made,
- Verify that physical construction has been completed,
- Inspect the quality and tightness of ground and surge protector connections,
- Check the power supply voltages and outputs,
- Connect devices to the power sources,
- Perform continuity tests on the surveillance camera's stranded conductor element using a meter having a minimum input resistance of 20,000 ohms per volt and show that each conductor has a resistance of not more than 16 ohms per 984.3 feet of conductor;
- Measure the insulation resistance between the conductors, and between each conductor, ground, and shield using a megger. The resistance must be infinity. Perform all resistance testing after final termination and cable installation, but prior to the connection of any electronics or field devices; and
- Replace any cable that fails to meet these parameters, or if any testing reveals defects in the cable, and retest new cable as specified; and
- Verify installation of specified cables and connections between the camera, PTZ, camera control receiver, and control cabinet,
- Perform the CCTV assembly manufacturer's initial power-on test in accordance with the manufacturer's recommendation,
- Set the camera control address,
- Verify the presence and quality of the video image in the field cabinet with a portable NTSC-approved monitor or laptop computer
- Exercise the pan, tilt, zoom, focus, iris opening, and manual iris control selections, and the operation, preset positioning, and power on/off functions,
- Demonstrate the pan and tilt speeds and extent of movement to meet all applicable standards, specifications, and requirements,
- Verify proper voltage of all power supplies, and

◆ **Revision No. 1, April 10, 2017 - This document supersedes version originally issued and sealed by J. Todd Brooks, NCPE No. 017586 on 12/28/2016**

U-4715B**ITS-348****Buncombe County**

- Interconnect the communication interface device with the communication network's assigned fiber-optic trunk cable and verify that there is a transmission LED illuminated.

Test the grounding system per ANSI/IEEE C62.41 and ANSI/IEEE C62.45 as applicable. Measure the ground impedance utilizing an instrument designed specifically to measure and document the ground impedance. Provide written test results of the ground impedance for each location to the engineer prior to backfilling the grounding electrode. The test results shall include the instrument model, date of instrument calibration, and local environmental conditions at the time of testing. Certify and sign the test results by the Contractor.

Repair or replace defective or failed equipment and retest.

F. Digital Video Equipment

Test the components of the digital video equipment as follows:

- Check all ground, power, data, Ethernet and digital video connections,
- Run power up self test on each piece of equipment,
- Run all available vendor-supplied self-diagnostics.

G. UPS

Perform the following operational tests for each UPS in accordance with the test plans. After the UPS has been installed:

- Connect all field devices to UPS,
- Connect UPS monitoring cable to managed Ethernet switch,
- Install and configure UPS monitoring software from the TMC, and
- Configure monitoring software for remote notifications of power outage and use of battery power.

Repair or replace defective or failed equipment and retest.

H. Ethernet Radio Equipment

Test the Ethernet radios as follows:

- Check all ground, power, data, Ethernet and analog video connections,
- Run power up self test on each piece of equipment,
- Run all available Vendor-supplied self-diagnostics,
- Check received signal strength, noise levels, bandwidth, and accuracy of test data transmission between each pair of nodes,
- Adjust hopping patterns as necessary to maximize the quality of the signal strength,
- If adjusting the hopping pattern does not significantly improve the quality of the signal strength, then adjust antenna as necessary to maximize the quality of the signal strength, and
- Test the transmission of data to ensure the transmission of data from the spread spectrum radios to the edge switches. Run the system diagnostics from end to end.

◆ **Revision No. 1, April 10, 2017 - This document supersedes version originally issued and sealed by J. Todd Brooks, NCPE No. 017586 on 12/28/2016**

U-4715B

ITS-349

Buncombe County

46.3. SYSTEM TESTING

A. General

Conduct tests as described below of the traffic signal and CCTV subsystems. Conduct approved device subsystem tests on the field equipment with the TMC equipment including, at a minimum, all remote communications hardware monitoring and control functions. These tests shall be a demonstration of overall system stability. During this test period, limit downtime due to mechanical, electrical, or other malfunctions to a maximum of eight hours. The Engineer has the right to suspend the test to correct deficiencies and restart the test or to extend the test period by time equal to the downtime in excess of eight hours.

Conduct device and subsystem tests of any repaired or replaced equipment.

Display the event log from the traffic signal and CCTV software for a minimum of seven days. Complete approved data forms and turn them over to the Engineer for review, and as a basis for rejection or acceptance.

The Engineer has the right to suspend the test to correct deficiencies and restart the test or to extend the test period by time equal to the downtime in excess of eight hours. If a component has been modified as a result of a test failure, prepare a report and deliver it to the Engineer prior to retesting.

B. CCTV Subsystem

After completing the integration of the CCTV cameras into the CCTV subsystem software, conduct a minimum of a seven-day test of the CCTV subsystem hardware and software. This will include that portion of the communications network serving the CCTV subsystem. The Engineer has the right to suspend the test to correct deficiencies and restart the test or to extend the test period by time equal to the downtime in excess of eight hours. If during that time it is determined by the Department or the City there are hardware or software failures that are the responsibility of the Contractor, the Contractor shall make repairs or replacements to the satisfaction of the Department and the City.

Test the following features of each competent as described below.

1. CCTV Field Equipment

The following items, not otherwise required to be tested elsewhere, shall be tested for each CCTV site from the TMC:

- Power-up self-tests,
- Iris control,
- Preset functions,
- Presence and quality of the video image,
- Preset positioning, and power on/off functions,
- Camera and controller access and security from all laptops and workstations,
- Disconnect camera and take local control and reconnect camera at local cabinet to the communications and verify TMC control is regained,
- Confirm ability to change camera ID,
- Verify unique camera identifier and icons on GUI,
- Viewing of camera image on each monitor.

◆ **Revision No. 1, April 10, 2017 - This document supersedes version originally issued and sealed by J. Todd Brooks, NCPE No. 017586 on 12/28/2016**

2. Digital Video Equipment

Thoroughly test all functions of the software from the TMC and the City Transportation Department to ensure correct operation. Test the components of the CCTV central equipment from both the TMC and the City Transportation Department as follows:

- Use the GUI interface and the PTZ control to select and view each camera on any monitor in the TMC and the City Transportation Department;
- Use and the GUI interface and the PTZ control from the TMC and the City's Transportation Department to test the ability to control the pan-tilt-zoom and iris settings of each camera;
- Use the GUI interface and the PTZ control and test the ability to select and place any camera on any monitor;
- Use the monitors with CATV access in the TMC to select and display cable TV channels;
- Test the ability to retrieve any archived video from the NVR and display on the monitor wall in the TMC;
- Utilizing each workstation, demonstrate the ability to select, control and view the camera images; and
- Verify that all CCTV images can be displayed correctly on each monitor using the CCTV central software.

3. CCTV Central Software

Thoroughly test all functions of the software from the TMC and the City Transportation Department to ensure correct operation. Test the components of the CCTV central equipment from both the TMC and the City Transportation Department as follows:

- Use the GUI interface to select and view each camera;
- Use and the GUI interface to test the ability to control the pan-tilt-zoom and iris settings of each camera; and
- Use the GUI interface and test the ability to select and place any camera on any monitor.

C. Traffic Signal Subsystem

After completion of the integration of the traffic signals into the new signal system central software, conduct a minimum of a seven-day test of the traffic signal subsystem hardware and that portion of the communications network serving the traffic signal subsystem. The Engineer has the right to suspend the test to correct deficiencies and restart the test or to extend the test period by time equal to the downtime in excess of eight hours. If during that time it is determined by the Department that there are failures that are the responsibility of the Contractor, the Contractor shall make repairs or replacements to the satisfaction of the Department.

Verify communications port addressing from the traffic signal controllers.

D. System Operational Test

All equipment and software provided in this project shall be fully installed and operational prior to the start of the system operational test. These test procedures shall demonstrate that all equipment is fully integrated and operational, and is properly controlling the system.

◆ **Revision No. 1, April 10, 2017 - This document supersedes version originally issued and sealed by J. Todd Brooks, NCPE No. 017586 on 12/28/2016**

U-4715B**ITS-351****Buncombe County**

Testing of the software and hardware at the TMC, remote video operation facilities and other necessary locations shall include demonstrating proper operation based on these Project Special Provisions. These tests shall also demonstrate the proper function of the CCTV surveillance system, including camera selection, pan/tilt/zoom functions and remote monitoring of video images. These tests shall also demonstrate the proper operation of the new intersections on the graphics display system, the full functionality of the installed operator workstations, and demonstrating proper reception of video signals on the monitor and control panels.

Submit a system acceptance test procedure to the Engineer for review and approval before any tests are conducted.

Submit a system operational test plan a minimum of 60 days prior to the scheduled start of the test. The test plan will be reviewed by the Engineer, who will then either approve it or indicate changes required for approval. The Contractor shall then submit the revised test plan for review and approval. This process shall be repeated until the Engineer is able to approve the test plan.

Provide an operational test matrix at least four weeks prior to the scheduled beginning of the system operational test. The test matrix shall include columns for a description of the test, a summary of the test procedures, a column with sufficient space for comments and a status (pass/fail) column.

Repair or replace any component or software module that fails the system operational test. Retest repaired or replace component(s) or software module.

Testing shall include but not be limited to the following:

- Demonstration of all key functions of the distributed processing signal system software, including but not limited to:
 - Uploading and downloading of controller data;
 - Remote access and paging;
 - All monitoring functions;
 - Detector logging;
 - Signal monitor logging and uploading;
 - Traffic responsive operations;
 - Event scheduler;
 - Security functions;
 - Graphic displays; and
 - Reports.
- Power failure recovery, auto reboot and startup of the distributed processing signal system software;
- Database access, modification, storage and retrieval;
- Remote access to the signal system software and CCTV software from the notebook computers and remote video operation facilities;

◆ **Revision No. 1, April 10, 2017 - This document supersedes version originally issued and sealed by J. Todd Brooks, NCPE No. 017586 on 12/28/2016**

U-4715B**ITS-352****Buncombe County**

- Local area network (LAN) operations; and
- Demonstrating that all features of the CCTV central software operates as called for with all field equipment.

46.4. OBSERVATION PERIOD**A. General**

A 60-day Observation Period shall begin upon the successful completion of all installed site tests, all subsystem tests and all system tests described in the preceding subsections as well as the correction of all known deficiencies, including minor construction items and punch-list items developed by the Engineer. During this period the Department and the City shall observe equipment and software operation to determine that all components of the fiber-optic communications system operate properly and interface with the traffic signal subsystem components and CCTV subsystem components according to the requirements of the Plans and these Project Special Provisions over an extended period of time.

During the Observation Period, respond to failures of the Contractor's equipment within two hours and make repairs within eight hours. For items that pose a traffic safety hazard such as a controller failure, make repairs within four hours. If any failures affect major system components for more than 48 hours, the Department shall suspend the Observation Period beginning when the failure occurred. Resume the Observation Period after successful repair or replacement. Failures of the following types will cause the Department to terminate the Observation Period and restart the Observation Period from zero once the failures have been corrected:

1. System or component failures that necessitate a redesign of any component; and
2. Three or more major system component failures of like nature within any 30-day period.

Major system components include:

- Ethernet core switch and Ethernet edge switches;
- Fiber-optic communications network;
- Ethernet radio equipment;
- LAN and the TMC and City Transportation Department computer equipment; and
- CCTV equipment.

Begin a new 60-day Observation Period with the approval of the Engineer after the faulty equipment has been repaired or replaced and the redesigned components have been installed.

A successful 60-day Observation Period shall consist of continuous operation with no more than a total of five calendar days of non-operation due to mechanical, electrical, or other malfunctions.

The Observation Period shall be completed by the project completion date and prior to final acceptance of the project. The Observation Period shall not begin until the both the CCTV and traffic signal subsystem tests have been successfully completed. The Observation Period shall not begin without the approval of the Engineer.

◆ Revision No. 1, April 10, 2017 - This document supersedes version originally issued and sealed by J. Todd Brooks, NCPE No. 017586 on 12/28/2016

U-4715B**ITS-353****Buncombe County****B. CCTV Subsystem**

During the Observation Period, the Department and the City will observe equipment and software operation according to the requirements of the Plans and these Project Special Provisions. Verify that the TRTMC can view and control the proposed cameras.

Major subsystem components include the CCTV cameras, Ethernet radio equipment, Ethernet switches, fiber-optic cable, CCTV monitors, network video recorder, PTZ controls, CCTV software, and CCTV cabinets.

C. Traffic Signal Subsystem

During the Observation Period, the Department and the City will observe equipment and software operation according to the requirements of the Plans and these Project Special Provisions.

Major subsystem components include the all Ethernet switches, Ethernet radio equipment, fiber-optic cable, controllers and conflict monitors, and cabinets.

46.5. MEASUREMENT AND PAYMENT

There will be no direct payment for work covered in this section. Payment at the contract unit prices for the various items in the contract will be full compensation for all work covered by this section.

46.6. FINAL ACCEPTANCE

Final system acceptance is defined as the time when all work and materials described in the Plans and these Project Special Provisions have been furnished and completely installed by the Contractor; all parts of the work have been approved and accepted by the Engineer; and the CCTV and signal subsystems have been operated continuously and successfully for the 60-day Observation Period.

Final acceptance shall not occur until:

- All field demonstration, installed site, system, and operational tests have been satisfactorily completed;
- All punch-list discrepancies have been rectified;
- All documentation has been delivered and accepted; and
- All required training has been completed.

County : Buncombe

| Line # | Item Number | Sec # | Description | Quantity | Unit Cost | Amount |
|----------------------|--------------|-------|---|--------------|-----------|--------|
| ROADWAY ITEMS | | | | | | |
| 0001 | 0000100000-N | 800 | MOBILIZATION | Lump Sum | L.S. | |
| 0002 | 2738000000-E | SP | GENERIC PAVING ITEM 4" CONCRETE SIDEWALK | 25 SY | | |
| 0003 | 4405000000-E | 1110 | WORK ZONE SIGNS (PORTABLE) | 840 SF | | |
| 0004 | 4410000000-E | 1110 | WORK ZONE SIGNS (BARRICADE MOUNTED) | 72 SF | | |
| 0005 | 4415000000-N | 1115 | FLASHING ARROW BOARD | 3 EA | | |
| 0006 | 4420000000-N | 1120 | PORTABLE CHANGEABLE MESSAGE SIGN | 3 EA | | |
| 0007 | 4430000000-N | 1130 | DRUMS | 150 EA | | |
| 0008 | 4435000000-N | 1135 | CONES | 150 EA | | |
| 0009 | 4445000000-E | 1145 | BARRICADES (TYPE III) | 50 LF | | |
| 0010 | 4450000000-N | 1150 | FLAGGER | 400 HR | | |
| 0011 | 4480000000-N | 1165 | TMA | 3 EA | | |
| 0012 | 4510000000-N | SP | LAW ENFORCEMENT | 450 HR | | |
| 0013 | 4516000000-N | 1180 | SKINNY DRUM | 100 EA | | |
| 0014 | 4697000000-E | 1205 | THERMOPLASTIC PAVEMENT MARKING LINES (8", 120 MILS) | 290 LF | | |
| 0015 | 4710000000-E | 1205 | THERMOPLASTIC PAVEMENT MARKING LINES (24", 120 MILS) | 740 LF | | |
| 0016 | 4870000000-E | 1205 | REMOVAL OF PAVEMENT MARKING LINES (24") | 12 LF | | |
| 0017 | 7048500000-E | 1705 | PEDESTRIAN SIGNAL HEAD (16", 1 SECTION W/COUNTDOWN) | 46 EA | | |
| 0018 | 7060000000-E | 1705 | SIGNAL CABLE | 56,220 LF | | |
| 0019 | 7120000000-E | 1705 | VEHICLE SIGNAL HEAD (12", 3 SECTION) | 159 EA | | |

County : Buncombe

| Line # | Item Number | Sec # | Description | Quantity | Unit Cost | Amount |
|--------|--------------|-------|--|---------------|-----------|--------|
| 0020 | 7132000000-E | 1705 | VEHICLE SIGNAL HEAD (12", 4 SECTION) | 110 EA | | |
| 0021 | 7144000000-E | 1705 | VEHICLE SIGNAL HEAD (12", 5 SECTION) | 6 EA | | |
| 0022 | 7229000000-N | SP | APS DETECTOR STATION | 30 EA | | |
| 0023 | 7230000000-N | SP | CENTRAL CONTROL UNIT APS DETECTOR STATION | 4 EA | | |
| 0024 | 7252000000-E | 1710 | MESSENGER CABLE (1/4") | 243,940 LF | | |
| 0025 | 7264000000-E | 1710 | MESSENGER CABLE (3/8") | 970 LF | | |
| 0026 | 7279000000-E | 1715 | TRACER WIRE | 113,700 LF | | |
| 0027 | 7301000000-E | 1715 | DIRECTIONAL DRILL (***** (1, 2")) | 830 LF | | |
| 0028 | 7301000000-E | 1715 | DIRECTIONAL DRILL (***** (2, 2")) | 41,320 LF | | |
| 0029 | 7312000000-N | 1716 | JUNCTION BOX (***** (SPECIAL-SIZED) | 81 EA | | |
| 0030 | 7324000000-N | 1716 | JUNCTION BOX (STANDARD SIZE) | 31 EA | | |
| 0031 | 7348000000-N | 1716 | JUNCTION BOX (OVER-SIZED, HEAVY DUTY) | 355 EA | | |
| 0032 | 7360000000-N | 1720 | WOOD POLE | 5 EA | | |
| 0033 | 7372000000-N | 1721 | GUY ASSEMBLY | 507 EA | | |
| 0034 | 7384000000-E | 1722 | ***" RISER WITH ***** (1", HEAT SHRINK TUBING) | 5 EA | | |
| 0035 | 7384000000-E | 1722 | ***" RISER WITH ***** (1.25", HEAT SHRINK TUBING) | 25 EA | | |
| 0036 | 7396000000-E | 1722 | 1/2" RISER WITH WEATHERHEAD | 8 EA | | |
| 0037 | 7408000000-E | 1722 | 1" RISER WITH WEATHERHEAD | 27 EA | | |

County : Buncombe

| Line # | Item Number | Sec # | Description | Quantity | Unit Cost | Amount |
|--------|--------------|-------|---|---------------|-----------|--------|
| 0038 | 7420000000-E | 1722 | 2" RISER WITH WEATHERHEAD | 50 EA | | |
| 0039 | 7430000000-N | 1722 | HEAT SHRINK TUBING RETROFIT KIT | 142 EA | | |
| 0040 | 7432000000-E | 1722 | 2" RISER WITH HEAT SHRINK TUBING | 197 EA | | |
| 0041 | 7444000000-E | 1725 | INDUCTIVE LOOP SAWCUT | 1,336 LF | | |
| 0042 | 7456000000-E | 1726 | LEAD-IN CABLE (***** (14-2) | 28,200 LF | | |
| 0043 | 7516000000-E | 1730 | COMMUNICATIONS CABLE (**FIBER) (24) | 313,780 LF | | |
| 0044 | 7516000000-E | 1730 | COMMUNICATIONS CABLE (**FIBER) (60) | 131,710 LF | | |
| 0045 | 7516000000-E | 1730 | COMMUNICATIONS CABLE (**FIBER) (96) | 55,880 LF | | |
| 0046 | 7528000000-E | 1730 | DROP CABLE | 79,610 LF | | |
| 0047 | 7540000000-N | 1731 | SPLICE ENCLOSURE | 237 EA | | |
| 0048 | 7552000000-N | 1731 | INTERCONNECT CENTER | 265 EA | | |
| 0049 | 7566000000-N | 1733 | DELINEATOR MARKER | 108 EA | | |
| 0050 | 7575142200-N | SP | NEW ELECTRICAL SERVICE | 32 EA | | |
| 0051 | 7575160000-E | 1734 | REMOVE EXISTING COMMUNICATIONS CABLE | 20,990 LF | | |
| 0052 | 7575180000-N | 1735 | CABLE TRANSFER | 10 EA | | |
| 0053 | 7636000000-N | 1745 | SIGN FOR SIGNALS | 10 EA | | |
| 0054 | 7642100000-N | 1743 | TYPE I POST WITH FOUNDATION | 22 EA | | |
| 0055 | 7642200000-N | 1743 | TYPE II PEDESTAL WITH FOUND- ATION | 4 EA | | |
| 0056 | 7648000000-N | 1746 | RELOCATE EXISTING SIGN | 1 EA | | |

County : Buncombe

| Line # | Item Number | Sec # | Description | Quantity | Unit Cost | Amount |
|--------|--------------|-------|--|----------|-----------|--------|
| 0057 | 7684000000-N | 1750 | SIGNAL CABINET FOUNDATION | 5 | EA | |
| 0058 | 7686000000-N | 1752 | CONDUIT ENTRANCE INTO EXISTING FOUNDATION | 35 | EA | |
| 0059 | 7687000000-N | 1752 | MODIFY FOUNDATION FOR CONTROLLER CABINET | 3 | EA | |
| 0060 | 7696000000-N | 1751 | CONTROLLER WITH CABINET (*****) (2070E, 332, BASE MOUNTED) | 5 | EA | |
| 0061 | 7696000000-N | 1751 | CONTROLLER WITH CABINET (*****) (2070E, 336S BASE MOUNTED) | 25 | EA | |
| 0062 | 7696000000-N | 1751 | CONTROLLER WITH CABINET (*****) (2070E, 336S POLE MOUNTED) | 34 | EA | |
| 0063 | 7708000000-N | 1751 | DETECTOR CARD (*****) (MODEL 222) | 1,613 | EA | |
| 0064 | 7901000000-N | 1753 | CABINET BASE EXTENDER | 50 | EA | |
| 0065 | 7901010000-N | 1753 | CABINET BASE ADAPTER | 3 | EA | |
| 0066 | 7980000000-N | SP | GENERIC SIGNAL ITEM 2.4 GHZ ETHERNET RADIO | 4 | EA | |
| 0067 | 7980000000-N | SP | GENERIC SIGNAL ITEM 5/8" X 10' GROUNDING ELECTRODE | 128 | EA | |
| 0068 | 7980000000-N | SP | GENERIC SIGNAL ITEM 900 MHZ ETHERNET RADIO | 34 | EA | |
| 0069 | 7980000000-N | SP | GENERIC SIGNAL ITEM CCTV CABINET | 16 | EA | |
| 0070 | 7980000000-N | SP | GENERIC SIGNAL ITEM CCTV CABINET DISCONNECT | 2 | EA | |
| 0071 | 7980000000-N | SP | GENERIC SIGNAL ITEM CCTV CAMERA ASSEMBLY | 29 | EA | |
| 0072 | 7980000000-N | SP | GENERIC SIGNAL ITEM CCTV TEST CABINET | 1 | EA | |

County : Buncombe

| Line # | Item Number | Sec # | Description | Quantity | Unit Cost | Amount |
|--------|--------------|-------|--|-----------|-----------|--------|
| 0073 | 7980000000-N | SP | GENERIC SIGNAL ITEM CCTV WOOD POLE | 14 EA | | |
| 0074 | 7980000000-N | SP | GENERIC SIGNAL ITEM COMMUNICATIONS RACK | 2 EA | | |
| 0075 | 7980000000-N | SP | GENERIC SIGNAL ITEM COMPUTER WORKSTATION | 4 EA | | |
| 0076 | 7980000000-N | SP | GENERIC SIGNAL ITEM CONTROLLER WITH CABINET & AUX FILE (2070E, 332, BASE MOUNT- ED) | 212 EA | | |
| 0077 | 7980000000-N | SP | GENERIC SIGNAL ITEM DIGITAL DISPLAY MONITOR | 3 EA | | |
| 0078 | 7980000000-N | SP | GENERIC SIGNAL ITEM ETHERNET CORE SWITCH | 1 EA | | |
| 0079 | 7980000000-N | SP | GENERIC SIGNAL ITEM ETHERNET EDGE SWITCH | 291 EA | | |
| 0080 | 7980000000-N | SP | GENERIC SIGNAL ITEM FIREWALL | 1 EA | | |
| 0081 | 7980000000-N | SP | GENERIC SIGNAL ITEM FURNISH 2.4 GHZ ETHERNET RADIO | 1 EA | | |
| 0082 | 7980000000-N | SP | GENERIC SIGNAL ITEM FURNISH 2018 ENHANCED CONFLICT MONITOR | 14 EA | | |
| 0083 | 7980000000-N | SP | GENERIC SIGNAL ITEM FURNISH 2070E CONTROLLER | 14 EA | | |
| 0084 | 7980000000-N | SP | GENERIC SIGNAL ITEM FURNISH 332 CABINET | 11 EA | | |
| 0085 | 7980000000-N | SP | GENERIC SIGNAL ITEM FURNISH 336S CABINET | 3 EA | | |
| 0086 | 7980000000-N | SP | GENERIC SIGNAL ITEM FURNISH 900 MHZ ETHERNET RADIO | 2 EA | | |
| 0087 | 7980000000-N | SP | GENERIC SIGNAL ITEM FURNISH CCTV CABINET | 1 EA | | |
| 0088 | 7980000000-N | SP | GENERIC SIGNAL ITEM FURNISH CCTV CAMERA ASSEMBLY | 2 EA | | |

County : Buncombe

| Line # | Item Number | Sec # | Description | Quantity | Unit Cost | Amount |
|--------|--------------|-------|--|----------|-----------|--------|
| 0089 | 7980000000-N | SP | GENERIC SIGNAL ITEM FURNISH CONFLICT MONITOR TEST- ER | 2 EA | | |
| 0090 | 7980000000-N | SP | GENERIC SIGNAL ITEM FURNISH DETECTOR CARD (MODEL 222) | 81 EA | | |
| 0091 | 7980000000-N | SP | GENERIC SIGNAL ITEM FURNISH ETHERNET EDGE SWITCH | 15 EA | | |
| 0092 | 7980000000-N | SP | GENERIC SIGNAL ITEM FURNISH FIBER-OPTIC POWER METER | 2 EA | | |
| 0093 | 7980000000-N | SP | GENERIC SIGNAL ITEM FURNISH FIBER-OPTIC RESTORA- TION KIT | 1 EA | | |
| 0094 | 7980000000-N | SP | GENERIC SIGNAL ITEM FURNISH OPTICAL LIGHT GENERA- TOR | 4 EA | | |
| 0095 | 7980000000-N | SP | GENERIC SIGNAL ITEM FURNISH SPARE CABLE & CONNec- TORS KIT | 1 EA | | |
| 0096 | 7980000000-N | SP | GENERIC SIGNAL ITEM FURNISH VIDEO MONITOR | 1 EA | | |
| 0097 | 7980000000-N | SP | GENERIC SIGNAL ITEM FURNISH VISUAL FAULT LOCATOR | 2 EA | | |
| 0098 | 7980000000-N | SP | GENERIC SIGNAL ITEM GUY ASSEMBLY (AERIAL) | 41 EA | | |
| 0099 | 7980000000-N | SP | GENERIC SIGNAL ITEM GUY ASSEMBLY (SIDEWALK) | 61 EA | | |
| 0100 | 7980000000-N | SP | GENERIC SIGNAL ITEM ITS SERVER | 2 EA | | |
| 0101 | 7980000000-N | SP | GENERIC SIGNAL ITEM KVM SWITCH | 1 EA | | |
| 0102 | 7980000000-N | SP | GENERIC SIGNAL ITEM LAPTOP COMPUTER | 7 EA | | |
| 0103 | 7980000000-N | SP | GENERIC SIGNAL ITEM MODIFY EXISTING ELECTRICAL SERVICE | 5 EA | | |

County : Buncombe

| Line # | Item Number | Sec # | Description | Quantity | Unit Cost | Amount |
|--------|--------------|-------|--|----------|-----------|--------|
| 0104 | 7980000000-N | SP | GENERIC SIGNAL ITEM MODIFY EXISTING SPLICE | 4 EA | | |
| 0105 | 7980000000-N | SP | GENERIC SIGNAL ITEM MODIFY VIDEO SERVER | 1 EA | | |
| 0106 | 7980000000-N | SP | GENERIC SIGNAL ITEM MW VEH DET SYS - MULTI ZONE | 1 EA | | |
| 0107 | 7980000000-N | SP | GENERIC SIGNAL ITEM NETWORK VIDEO RECORDER | 1 EA | | |
| 0108 | 7980000000-N | SP | GENERIC SIGNAL ITEM POLE-MOUNT RADIO CABINET | 2 EA | | |
| 0109 | 7980000000-N | SP | GENERIC SIGNAL ITEM PRINTER | 1 EA | | |
| 0110 | 7980000000-N | SP | GENERIC SIGNAL ITEM PTZ JOYSTICK | 1 EA | | |
| 0111 | 7980000000-N | SP | GENERIC SIGNAL ITEM REMOVE SPLICE/HUB CABINET | 1 EA | | |
| 0112 | 7980000000-N | SP | GENERIC SIGNAL ITEM REMOVE SPLICE/HUB CABINET FOUNDATION | 1 EA | | |
| 0113 | 7980000000-N | SP | GENERIC SIGNAL ITEM SOLAR POWER ASSEMBLY | 2 EA | | |
| 0114 | 7980000000-N | SP | GENERIC SIGNAL ITEM SPECIAL COATING (332 CABINET) | 5 EA | | |
| 0115 | 7980000000-N | SP | GENERIC SIGNAL ITEM SPECIAL COATING (336 CABINET) | 2 EA | | |
| 0116 | 7980000000-N | SP | GENERIC SIGNAL ITEM SPECIAL COATING (BASE EXTENDER /ADAPTER) | 5 EA | | |
| 0117 | 7980000000-N | SP | GENERIC SIGNAL ITEM SURFACE MOUNTED JUNCTION BOX | 4 EA | | |
| 0118 | 7980000000-N | SP | GENERIC SIGNAL ITEM TERMINAL SPLICE CABINET | 1 EA | | |
| 0119 | 7980000000-N | SP | GENERIC SIGNAL ITEM TEST CONTROLLER WITH CABINET | 1 EA | | |

County : Buncombe

| Line # | Item Number | Sec # | Description | Quantity | Unit Cost | Amount |
|--------|--------------|-------|--|--------------|-----------|--------|
| 0120 | 7980000000-N | SP | GENERIC SIGNAL ITEM UPS (TMC) | 1 EA | | |
| 0121 | 7985000000-N | SP | GENERIC SIGNAL ITEM CITY HALL MODIFICATIONS | Lump Sum | L.S. | |
| 0122 | 7985000000-N | SP | GENERIC SIGNAL ITEM DIVISION 13 OFFICE MODIFICA- TIONS | Lump Sum | L.S. | |
| 0123 | 7985000000-N | SP | GENERIC SIGNAL ITEM MODIFY CCTV SOFTWARE | Lump Sum | L.S. | |
| 0124 | 7985000000-N | SP | GENERIC SIGNAL ITEM NETWORK MANAGEMENT SOFTWARE | Lump Sum | L.S. | |
| 0125 | 7985000000-N | SP | GENERIC SIGNAL ITEM SIGNAL SYSTEM SOFTWARE | Lump Sum | L.S. | |
| 0126 | 7985000000-N | SP | GENERIC SIGNAL ITEM SYSTEM SUPPORT SOFTWARE AND DEVICES | Lump Sum | L.S. | |
| 0127 | 7985000000-N | SP | GENERIC SIGNAL ITEM TMC MODIFICATIONS | Lump Sum | L.S. | |
| 0128 | 7985000000-N | SP | GENERIC SIGNAL ITEM TRAINING | Lump Sum | L.S. | |
| 0129 | 7990000000-E | SP | GENERIC SIGNAL ITEM AERIAL CABLE PROTECTOR | 880 LF | | |
| 0130 | 7990000000-E | SP | GENERIC SIGNAL ITEM ETHERNET CABLE | 675 LF | | |
| 0131 | 7990000000-E | SP | GENERIC SIGNAL ITEM PLENUM-RATED COMMUNICATIONS CABLE (24 FIBER) | 300 LF | | |
| 0132 | 7990000000-E | SP | GENERIC SIGNAL ITEM UNDERGROUND CONDUIT (1, 2") | 1,965 LF | | |
| 0133 | 7990000000-E | SP | GENERIC SIGNAL ITEM UNDERGROUND CONDUIT (2, 2") | 42,390 LF | | |
| 0134 | 7990000000-E | SP | GENERIC SIGNAL ITEM WALL-MOUNTED CONDUIT (1.25") | 1,065 LF | | |

County : Buncombe

| Line # | Item Number | Sec # | Description | Quantity | Unit Cost | Amount |
|--------|--------------|-------|-------------------------------------|-----------|-----------|--------|
| 0135 | 7991000000-E | SP | GENERIC SIGNAL ITEM BRICK PAVERS | 100 SF | | |

1034/Feb21/Q1144458.0/D990155392200/E135

Total Amount Of Bid For Entire Project :

DBE GOAL SET: 1.00%
DBE GOAL OBT: 1.35%

Vendor 1 of 3: BROOKS BERRY HAYNIE & ASSOCIATES, INC.
(3560)
Call Order 007 (Proposal: C203953)

Bid Information

| | |
|---|-------------------------------------|
| Proposal County: BUNCOMBE | Bid Checksum: E4D6E7F4 |
| Vendor Address: 600 Discovery Pl Mableton , Georgia , 30126 | Bid Total: \$10,649,690.08 |
| Signature Check: Alex_Owen_3560 | Items Total: \$10,649,690.08 |
| Time Bid Received: April 18, 2017 11:56 AM | Time Total: \$0.00 |
| Amendment Count: 0 | |

Bidding Errors:
None.

Vendor 1 of 3: BROOKS BERRY HAYNIE & ASSOCIATES, INC.
(3560)
Call Order 007 (Proposal: C203953)

Bid Bond Information

| | |
|-----------------------------|--|
| Projects: | Bond Maximum: |
| Counties: | State of Incorporation: |
| Bond ID: SNC17835586 | Agency Execution Date: 3/22/2017 12 |
| Paid by Check: No | Surety Name: surety2000 |
| Bond Percent: 5% | Bond Agency Name: Liberty Mutual Insurance Company |

Bidder 1 of 3

Vendor 3560's Bid Information for Call 007, Letting L170418, 04/18/17

Brooks-Berry-Haynie & Associates, Inc. (3560)
Call Order 007 (Proposal ID C203953)

LIST OF DBE PARTICIPANTS

| VENDOR NUMBER | DBE NAME ADDRESS | WORK CODE TYPE OF WORK | CERT TYPE AMOUNT | |
|---------------|---|------------------------|---------------------|-----------|
| WB 8450 | CARLSON CONSTRUCTION SERVICES L P.O. BOX 669547 , MARIETTA, GA 30066 | | Sub 143,934.50 | COMMITTED |
| | | | TOTAL: \$143,934.50 | |
| | | | 1.35% | |

Vendor 3560's Bid Information for Call 007, Letting L170418, 04/18/17

Brooks-Berry-Haynie & Associates, Inc. (3560)
Call Order 007 (Proposal ID C203953)

Miscellaneous Data Info - Contractor Responses:
=====

NON-COLLUSION AND DEBARMENT CERTIFICATION

Explanation of the prospective bidder that is unable to certify to any of the statements in this certification:

Explanation:
NOT ANSWERED
NOT ANSWERED
NOT ANSWERED
NOT ANSWERED

AWARD LIMITS ON MULTIPLE PROJECTS

By answering YES to this statement, the bidder acknowledges that they are using the award limits on multiple projects. No

It is the desire of the Bidder to be awarded contracts, the value of which will not exceed a total of NOT ANSWERED for those projects indicated herein, for which bids will be opened on (MM/DD/YY)

The Award Limits shall apply to the following projects:

| Contract Number | County |
|-----------------|--------|
| NOT ANSWERED | |
| NOT ANSWERED | |
| NOT ANSWERED | |
| NOT ANSWERED | |
| NOT ANSWERED | |
| NOT ANSWERED | |

Bid Bond Data Info - Contractor Responses:
=====

BondID: SNC17835586
Surety Registry Agency: surety2000
Verified?: Yes

Bidder 2 of 3

Surety Agency: Travelers Casualty and Surety Company of America
Bond Execution Date: 4/13/2017 4
Bond Amount: \$593,683.40 (Five Percent of Bid)

Dept of Transportation

Revised:

Contract ID: C203953

Project(s): STP-1302(069)

Letting Date: 04-18-17 Call Order: 007

Bidder: 3560 - Brooks-Berry-Haynie & Associates, Inc.

| Line No. | Item Description | Approx. Quantity and Units | Unit Price Dollars Cts | Bid Amount Dollars Ct |
|----------------------------|--|----------------------------|--------------------------|-------------------------|
| Section 0001 ROADWAY ITEMS | | | | |
| Alt Group | | | | |
| 0001 | 0000100000-N MOBILIZATION | LUMP | LUMP | 215,000.00 |
| 0002 | 2738000000-E GENERIC PAVING ITEM 4" CONCRETE SIDEWALK | 25.000 SY | 178.40000 | 4,460.00 |
| 0003 | 4405000000-E WORK ZONE SIGNS (PORTABLE) | 840.000 SF | 132.00000 | 110,880.00 |
| 0004 | 4410000000-E WORK ZONE SIGNS (BARRICADE MOUNTED) | 72.000 SF | 100.50000 | 7,236.00 |
| 0005 | 4415000000-N FLASHING ARROW BOARD | 3.000 EA | 6,538.00000 | 19,614.00 |
| 0006 | 4420000000-N PORTABLE CHANGEABLE MESSAGE SIGN | 3.000 EA | 13,740.00000 | 41,220.00 |
| 0007 | 4430000000-N DRUMS | 150.000 EA | 190.00000 | 28,500.00 |
| 0008 | 4435000000-N CONES | 150.000 EA | 136.00000 | 20,400.00 |
| 0009 | 4445000000-E BARRICADES (TYPE III) | 50.000 LF | 271.00000 | 13,550.00 |
| 0010 | 4450000000-N FLAGGER | 400.000 HR | 49.60000 | 19,840.00 |
| 0011 | 4480000000-N TMA | 3.000 EA | 54,786.00000 | 164,358.00 |

Dept of Transportation

Revised:

Contract ID: C203953

Project(s): STP-1302(069)

Letting Date: 04-18-17 Call Order: 007

Bidder: 3560 - Brooks-Berry-Haynie & Associates, Inc.

| Line No. | Item Description | Approx. Quantity and Units | Unit Price Dollars Cts | Bid Amount Dollars Ct |
|----------|---|----------------------------|--------------------------|-------------------------|
| 0012 | 4510000000-N LAW ENFORCEMENT | 450.000 HR | 60.25000 | 27,112.50 |
| 0013 | 4516000000-N SKINNY DRUM | 100.000 EA | 11.90000 | 1,190.00 |
| 0014 | 4697000000-E THERMOPLASTIC PAVEMENT MARKING LINES (8", 120 MILS) | 290.000 LF | 4.82000 | 1,397.80 |
| 0015 | 4710000000-E THERMOPLASTIC PAVEMENT MARKING LINES (24", 120 MILS) | 740.000 LF | 18.08000 | 13,379.20 |
| 0016 | 4870000000-E REMOVAL OF PAVEMENT MARKING LINES (24") | 12.000 LF | 12.05000 | 144.60 |
| 0017 | 7048500000-E PEDESTRIAN SIGNAL HEAD (16", 1SECTION W/COUNTDOWN) | 46.000 EA | 450.00000 | 20,700.00 |
| 0018 | 7060000000-E SIGNAL CABLE | 56,220.000 LF | 1.55000 | 87,141.00 |
| 0019 | 7120000000-E VEHICLE SIGNAL HEAD (12", 3 SECTION) | 159.000 EA | 656.25000 | 104,343.75 |
| 0020 | 7132000000-E VEHICLE SIGNAL HEAD (12", 4 SECTION) | 110.000 EA | 818.00000 | 89,980.00 |
| 0021 | 7144000000-E VEHICLE SIGNAL HEAD (12", 5 SECTION) | 6.000 EA | 1,091.00000 | 6,546.00 |
| 0022 | 7229000000-N APS DETECTOR STATION | 30.000 EA | 817.00000 | 24,510.00 |
| 0023 | 7230000000-N CENTRAL CONTROL UNIT APS DETECTOR STATION | 4.000 EA | 2,998.00000 | 11,992.00 |

Dept of Transportation

Revised:

Contract ID: C203953

Project(s): STP-1302(069)

Letting Date: 04-18-17 Call Order: 007

Bidder: 3560 - Brooks-Berry-Haynie & Associates, Inc.

| Line No. | Item Description | Approx. Quantity and Units | Unit Price Dollars Cts | Bid Amount Dollars Ct |
|----------|---|----------------------------|--------------------------|-------------------------|
| 0024 | 7252000000-E MESSENGER CABLE (1/4") | 243,940.000 LF | 2.11000 | 514,713.40 |
| 0025 | 7264000000-E MESSENGER CABLE (3/8") | 970.000 LF | 7.50000 | 7,275.00 |
| 0026 | 7279000000-E TRACER WIRE | 113,700.000 LF | 0.45000 | 51,165.00 |
| 0027 | 7301000000-E DIRECTIONAL DRILL (***** (1, 2") | 830.000 LF | 11.15000 | 9,254.50 |
| 0028 | 7301000000-E DIRECTIONAL DRILL (***** (2, 2") | 41,320.000 LF | 14.15000 | 584,678.00 |
| 0029 | 7312000000-N JUNCTION BOX (***** (SPECIAL-SIZED) | 81.000 EA | 718.00000 | 58,158.00 |
| 0030 | 7324000000-N JUNCTION BOX (STANDARD SIZE) | 31.000 EA | 271.00000 | 8,401.00 |
| 0031 | 7348000000-N JUNCTION BOX (OVER-SIZED, HEA-VY DUTY) | 355.000 EA | 754.00000 | 267,670.00 |
| 0032 | 7360000000-N WOOD POLE | 5.000 EA | 1,193.00000 | 5,965.00 |
| 0033 | 7372000000-N GUY ASSEMBLY | 507.000 EA | 331.50000 | 168,070.50 |
| 0034 | 7384000000-E ***" RISER WITH ***** (1", HEAT SHRINK TUBING) | 5.000 EA | 562.00000 | 2,810.00 |

Contract ID: C203953

Project(s): STP-1302(069)

Letting Date: 04-18-17 Call Order: 007

Bidder: 3560 - Brooks-Berry-Haynie & Associates, Inc.

| Line No. | Item Description | Approx. Quantity and Units | Unit Price Dollars Cts | Bid Amount Dollars Ct |
|----------|--|----------------------------|--------------------------|-------------------------|
| 0035 | 7384000000-E ***" RISER WITH ***** (1.25", HEAT SHRINK TUBING) | 25.000 EA | 774.00000 | 19,350.00 |
| 0036 | 7396000000-E 1/2" RISER WITH WEATHERHEAD | 8.000 EA | 328.00000 | 2,624.00 |
| 0037 | 7408000000-E 1" RISER WITH WEATHERHEAD | 27.000 EA | 481.00000 | 12,987.00 |
| 0038 | 7420000000-E 2" RISER WITH WEATHERHEAD | 50.000 EA | 1,045.00000 | 52,250.00 |
| 0039 | 7430000000-N HEAT SHRINK TUBING RETROFIT KIT | 142.000 EA | 217.00000 | 30,814.00 |
| 0040 | 7432000000-E 2" RISER WITH HEAT SHRINK TUBING | 197.000 EA | 1,126.00000 | 221,822.00 |
| 0041 | 7444000000-E INDUCTIVE LOOP SAWCUT | 1,336.000 LF | 6.63000 | 8,857.68 |
| 0042 | 7456000000-E LEAD-IN CABLE (***** (14-2) | 28,200.000 LF | 1.48000 | 41,736.00 |
| 0043 | 7516000000-E COMMUNICATI ONS CABLE (**FIBER) (24) | 313,780.000 LF | 1.46000 | 458,118.80 |
| 0044 | 7516000000-E COMMUNICATI ONS CABLE (**FIBER) (60) | 131,710.000 LF | 1.77000 | 233,126.70 |
| 0045 | 7516000000-E COMMUNICATI ONS CABLE (**FIBER) (96) | 55,880.000 LF | 2.06000 | 115,112.80 |

Dept of Transportation

Revised:

Contract ID: C203953

Project(s): STP-1302(069)

Letting Date: 04-18-17 Call Order: 007

Bidder: 3560 - Brooks-Berry-Haynie & Associates, Inc.

| Line No. | Item Description | Approx. Quantity and Units | Unit Price Dollars Cts | Bid Amount Dollars Ct |
|----------|--|----------------------------|--------------------------|-------------------------|
| 0046 | 7528000000-E DROP CABLE LF | 79,610.000 | 1.75000 | 139,317.50 |
| 0047 | 7540000000-N SPLICE ENCLOSURE EA | 237.000 | 995.00000 | 235,815.00 |
| 0048 | 7552000000-N INTERCONNEC T CENTER EA | 265.000 | 904.00000 | 239,560.00 |
| 0049 | 7566000000-N DELINEATOR MARKER EA | 108.000 | 54.25000 | 5,859.00 |
| 0050 | 7575142200-N NEW ELECTRICAL SERVICE EA | 32.000 | 2,689.00000 | 86,048.00 |
| 0051 | 7575160000-E REMOVE EXISTING COMMUNICATIONSCABLE LF | 20,990.000 | 0.90000 | 18,891.00 |
| 0052 | 7575180000-N CABLE TRANSFER EA | 10.000 | 91.00000 | 910.00 |
| 0053 | 7636000000-N SIGN FOR SIGNALS EA | 10.000 | 320.00000 | 3,200.00 |
| 0054 | 7642100000-N TYPE I POST WITH FOUNDATION EA | 22.000 | 1,476.00000 | 32,472.00 |
| 0055 | 7642200000-N TYPE II PEDESTAL WITH FOUND- ATION EA | 4.000 | 2,015.00000 | 8,060.00 |
| 0056 | 7648000000-N RELOCATE EXISTING SIGN EA | 1.000 | 107.00000 | 107.00 |
| 0057 | 7684000000-N SIGNAL CABINET FOUNDATION EA | 5.000 | 5,504.00000 | 27,520.00 |

Dept of Transportation

Revised:

Contract ID: C203953

Project(s): STP-1302(069)

Letting Date: 04-18-17 Call Order: 007

Bidder: 3560 - Brooks-Berry-Haynie & Associates, Inc.

| Line No. | Item Description | Approx. Quantity and Units | Unit Price Dollars Cts | Bid Amount Dollars Ct |
|----------|--|----------------------------|--------------------------|-------------------------|
| 0058 | 7686000000-N CONDUIT ENTRANCE INTO EXISTING FOUNDATION | 35.000 EA | 754.00000 | 26,390.00 |
| 0059 | 7687000000-N MODIFY FOUNDATION FOR CONTROL-LER CABINET | 3.000 EA | 151.00000 | 453.00 |
| 0060 | 7696000000-N CONTROLLER WITH CABINET (*****) (2070E, 332, BASE MOUNTED) | 5.000 EA | 10,431.00000 | 52,155.00 |
| 0061 | 7696000000-N CONTROLLER WITH CABINET (*****) (2070E, 336S BASE MOUNTED) | 25.000 EA | 9,875.00000 | 246,875.00 |
| 0062 | 7696000000-N CONTROLLER WITH CABINET (*****) (2070E, 336S POLE MOUNTED) | 34.000 EA | 11,492.00000 | 390,728.00 |
| 0063 | 7708000000-N DETECTOR CARD (*****) (MODEL 222) | 1,613.000 EA | 103.00000 | 166,139.00 |
| 0064 | 7901000000-N CABINET BASE EXTENDER | 50.000 EA | 335.00000 | 16,750.00 |
| 0065 | 7901010000-N CABINET BASE ADAPTER | 3.000 EA | 515.00000 | 1,545.00 |
| 0066 | 7980000000-N GENERIC SIGNAL ITEM 2.4 GHZ ETHERNET RADIO | 4.000 EA | 4,502.00000 | 18,008.00 |
| 0067 | 7980000000-N GENERIC SIGNAL ITEM 5/8" X 10' GROUNDING ELECTRODE | 128.000 EA | 366.00000 | 46,848.00 |

Dept of Transportation

Revised:

Contract ID: C203953

Project(s): STP-1302(069)

Letting Date: 04-18-17 Call Order: 007

Bidder: 3560 - Brooks-Berry-Haynie & Associates, Inc.

| Line No. | Item Description | Approx. Quantity and Units | Unit Price Dollars Cts | Bid Amount Dollars Ct |
|----------|--|----------------------------|--------------------------|-------------------------|
| 0068 | 7980000000-N GENERIC SIGNAL ITEM 900 MHZ ETHERNET RADIO | 34.000 EA | 6,374.00000 | 216,716.00 |
| 0069 | 7980000000-N GENERIC SIGNAL ITEM CCTV CABINET | 16.000 EA | 5,766.00000 | 92,256.00 |
| 0070 | 7980000000-N GENERIC SIGNAL ITEM CCTV CABINET DISCONNECT | 2.000 EA | 340.00000 | 680.00 |
| 0071 | 7980000000-N GENERIC SIGNAL ITEM CCTV CAMERA ASSEMBLY | 29.000 EA | 3,865.00000 | 112,085.00 |
| 0072 | 7980000000-N GENERIC SIGNAL ITEM CCTV TEST CABINET | 1.000 EA | 3,038.00000 | 3,038.00 |
| 0073 | 7980000000-N GENERIC SIGNAL ITEM CCTV WOOD POLE | 14.000 EA | 3,635.00000 | 50,890.00 |
| 0074 | 7980000000-N GENERIC SIGNAL ITEM COMMUNICATIONS RACK | 2.000 EA | 2,893.00000 | 5,786.00 |
| 0075 | 7980000000-N GENERIC SIGNAL ITEM COMPUTER WORKSTATION | 4.000 EA | 3,156.00000 | 12,624.00 |
| 0076 | 7980000000-N GENERIC SIGNAL ITEM CONTROLLER WITH CABINET & AUX FILE (2070E, 332, BASE MOUNT- ED) | 212.000 EA | 11,835.00000 | 2,509,020.00 |
| 0077 | 7980000000-N GENERIC SIGNAL ITEM DIGITAL DISPLAY MONITOR | 3.000 EA | 1,972.00000 | 5,916.00 |
| 0078 | 7980000000-N GENERIC SIGNAL ITEM ETHERNET CORE SWITCH | 1.000 EA | 58,000.00000 | 58,000.00 |

Dept of Transportation

Revised:

Contract ID: C203953

Project(s): STP-1302(069)

Letting Date: 04-18-17 Call Order: 007

Bidder: 3560 - Brooks-Berry-Haynie & Associates, Inc.

| Line No. | Item Description | Approx. Quantity and Units | Unit Price Dollars Cts | Bid Amount Dollars Ct |
|----------|--|----------------------------|--------------------------|-------------------------|
| 0079 | 7980000000-N GENERIC SIGNAL ITEM ETHERNET EDGE SWITCH | 291.000 EA | 1,223.50000 | 356,038.50 |
| 0080 | 7980000000-N GENERIC SIGNAL ITEM FIREWALL | 1.000 EA | 3,255.00000 | 3,255.00 |
| 0081 | 7980000000-N GENERIC SIGNAL ITEM FURNISH 2.4 GHZ ETHERNET RADIO | 1.000 EA | 1,862.00000 | 1,862.00 |
| 0082 | 7980000000-N GENERIC SIGNAL ITEM FURNISH 2018 ENHANCED CONFLICTMONITOR | 14.000 EA | 952.00000 | 13,328.00 |
| 0083 | 7980000000-N GENERIC SIGNAL ITEM FURNISH 2070E CONTROLLER | 14.000 EA | 1,605.00000 | 22,470.00 |
| 0084 | 7980000000-N GENERIC SIGNAL ITEM FURNISH 332 CABINET | 11.000 EA | 7,363.00000 | 80,993.00 |
| 0085 | 7980000000-N GENERIC SIGNAL ITEM FURNISH 336S CABINET | 3.000 EA | 6,801.00000 | 20,403.00 |
| 0086 | 7980000000-N GENERIC SIGNAL ITEM FURNISH 900 MHZ ETHERNET RADIO | 2.000 EA | 1,507.00000 | 3,014.00 |
| 0087 | 7980000000-N GENERIC SIGNAL ITEM FURNISH CCTV CABINET | 1.000 EA | 2,676.00000 | 2,676.00 |
| 0088 | 7980000000-N GENERIC SIGNAL ITEM FURNISH CCTV CAMERA ASSEMBLY | 2.000 EA | 2,893.00000 | 5,786.00 |
| 0089 | 7980000000-N GENERIC SIGNAL ITEM FURNISH CONFLICT MONITOR TEST-ER | 2.000 EA | 17,347.00000 | 34,694.00 |

Dept of Transportation

Revised:

Contract ID: C203953

Project(s): STP-1302(069)

Letting Date: 04-18-17 Call Order: 007

Bidder: 3560 - Brooks-Berry-Haynie & Associates, Inc.

| Line No. | Item Description | Approx. Quantity and Units | Unit Price Dollars Cts | Bid Amount Dollars Ct |
|----------|--|----------------------------|--------------------------|-------------------------|
| 0090 | 7980000000-N GENERIC SIGNAL ITEM FURNISH DETECTOR CARD (MODEL 222) | 81.000 EA | 76.50000 | 6,196.50 |
| 0091 | 7980000000-N GENERIC SIGNAL ITEM FURNISH ETHERNET EDGE SWITCH | 15.000 EA | 1,164.00000 | 17,460.00 |
| 0092 | 7980000000-N GENERIC SIGNAL ITEM FURNISH FIBER-OPTIC POWER METER | 2.000 EA | 2,580.00000 | 5,160.00 |
| 0093 | 7980000000-N GENERIC SIGNAL ITEM FURNISH FIBER-OPTIC RESTORATION KIT | 1.000 EA | 3,224.00000 | 3,224.00 |
| 0094 | 7980000000-N GENERIC SIGNAL ITEM FURNISH OPTICAL LIGHT GENERATOR | 4.000 EA | 3,869.00000 | 15,476.00 |
| 0095 | 7980000000-N GENERIC SIGNAL ITEM FURNISH SPARE CABLE & CONNECTORS KIT | 1.000 EA | 3,224.00000 | 3,224.00 |
| 0096 | 7980000000-N GENERIC SIGNAL ITEM FURNISH VIDEO MONITOR | 1.000 EA | 1,422.00000 | 1,422.00 |
| 0097 | 7980000000-N GENERIC SIGNAL ITEM FURNISH VISUAL FAULT LOCATOR | 2.000 EA | 580.00000 | 1,160.00 |
| 0098 | 7980000000-N GENERIC SIGNAL ITEM GUY ASSEMBLY (AERIAL) | 41.000 EA | 331.50000 | 13,591.50 |
| 0099 | 7980000000-N GENERIC SIGNAL ITEM GUY ASSEMBLY (SIDEWALK) | 61.000 EA | 476.00000 | 29,036.00 |
| 0100 | 7980000000-N GENERIC SIGNAL ITEM ITS SERVER | 2.000 EA | 18,900.00000 | 37,800.00 |

Dept of Transportation

Revised:

Contract ID: C203953

Project(s): STP-1302(069)

Letting Date: 04-18-17 Call Order: 007

Bidder: 3560 - Brooks-Berry-Haynie & Associates, Inc.

| Line No. | Item Description | Approx. Quantity and Units | Unit Price Dollars Cts | Bid Amount Dollars Ct |
|----------|---|----------------------------|--------------------------|-------------------------|
| 0101 | 7980000000-N GENERIC SIGNAL ITEM KVM SWITCH | 1.000 EA | 3,134.00000 | 3,134.00 |
| 0102 | 7980000000-N GENERIC SIGNAL ITEM LAPTOP COMPUTER | 7.000 EA | 3,377.00000 | 23,639.00 |
| 0103 | 7980000000-N GENERIC SIGNAL ITEM MODIFY EXISTING ELECTRICAL SERVICE | 5.000 EA | 2,338.00000 | 11,690.00 |
| 0104 | 7980000000-N GENERIC SIGNAL ITEM MODIFY EXISTING SPLICE | 4.000 EA | 1,266.00000 | 5,064.00 |
| 0105 | 7980000000-N GENERIC SIGNAL ITEM MODIFY VIDEO SERVER | 1.000 EA | 4,339.00000 | 4,339.00 |
| 0106 | 7980000000-N GENERIC SIGNAL ITEM MW VEH DET SYS - MULTI ZONE | 1.000 EA | 8,250.00000 | 8,250.00 |
| 0107 | 7980000000-N GENERIC SIGNAL ITEM NETWORK VIDEO RECORDER | 1.000 EA | 8,594.00000 | 8,594.00 |
| 0108 | 7980000000-N GENERIC SIGNAL ITEM POLE-MOUNT RADIO CABINET | 2.000 EA | 5,868.00000 | 11,736.00 |
| 0109 | 7980000000-N GENERIC SIGNAL ITEM PRINTER | 1.000 EA | 2,650.00000 | 2,650.00 |
| 0110 | 7980000000-N GENERIC SIGNAL ITEM PTZ JOYSTICK | 1.000 EA | 1,085.00000 | 1,085.00 |
| 0111 | 7980000000-N GENERIC SIGNAL ITEM REMOVE SPLICE/HUB CABINET | 1.000 EA | 1,145.00000 | 1,145.00 |

Dept of Transportation

Revised:

Contract ID: C203953

Project(s): STP-1302(069)

Letting Date: 04-18-17 Call Order: 007

Bidder: 3560 - Brooks-Berry-Haynie & Associates, Inc.

| Line No. | Item Description | Approx. Quantity and Units | Unit Price Dollars Cts | Bid Amount Dollars Ct |
|----------|--|----------------------------|--------------------------|-------------------------|
| 0112 | 7980000000-N GENERIC SIGNAL ITEM REMOVE SPLICE/HUB CABINET FOUNDATION | 1.000 EA | 701.00000 | 701.00 |
| 0113 | 7980000000-N GENERIC SIGNAL ITEM SOLAR POWER ASSEMBLY | 2.000 EA | 9,315.00000 | 18,630.00 |
| 0114 | 7980000000-N GENERIC SIGNAL ITEM SPECIAL COATING (332 CABINET) | 5.000 EA | 240.00000 | 1,200.00 |
| 0115 | 7980000000-N GENERIC SIGNAL ITEM SPECIAL COATING (336 CABINET) | 2.000 EA | 240.00000 | 480.00 |
| 0116 | 7980000000-N GENERIC SIGNAL ITEM SPECIAL COATING (BASE EXTENDER/ADAPTER) | 5.000 EA | 240.00000 | 1,200.00 |
| 0117 | 7980000000-N GENERIC SIGNAL ITEM SURFACE MOUNTED JUNCTION BOX | 4.000 EA | 1,163.00000 | 4,652.00 |
| 0118 | 7980000000-N GENERIC SIGNAL ITEM TERMINAL SPLICE CABINET | 1.000 EA | 1,748.00000 | 1,748.00 |
| 0119 | 7980000000-N GENERIC SIGNAL ITEM TEST CONTROLLER WITH CABINET | 1.000 EA | 13,027.00000 | 13,027.00 |
| 0120 | 7980000000-N GENERIC SIGNAL ITEM UPS (TMC) | 1.000 EA | 4,339.00000 | 4,339.00 |
| 0121 | 7985000000-N GENERIC SIGNAL ITEM CITY HALL MODIFICATIONS | LUMP | LUMP | 21,140.00 |
| 0122 | 7985000000-N GENERIC SIGNAL ITEM DIVISION 13 OFFICE MODIFICATIONS | LUMP | LUMP | 13,712.00 |

Dept of Transportation

Revised:

Contract ID: C203953

Project(s): STP-1302(069)

Letting Date: 04-18-17 Call Order: 007

Bidder: 3560 - Brooks-Berry-Haynie & Associates, Inc.

| Line No. | Item Description | Approx. Quantity and Units | Unit Price Dollars Cts | Bid Amount Dollars Ct |
|----------|---|----------------------------|--------------------------|-------------------------|
| 0123 | 7985000000-N GENERIC SIGNAL ITEM MODIFY CCTV SOFTWARE | LUMP | LUMP | 5,062.00 |
| 0124 | 7985000000-N GENERIC SIGNAL ITEM NETWORK MANAGEMENT SOFTWARE | LUMP | LUMP | 20,250.00 |
| 0125 | 7985000000-N GENERIC SIGNAL ITEM SIGNAL SYSTEM SOFTWARE | LUMP | LUMP | 585,000.00 |
| 0126 | 7985000000-N GENERIC SIGNAL ITEM SYSTEM SUPPORT SOFTWARE AND DEVICES | LUMP | LUMP | 1,618.00 |
| 0127 | 7985000000-N GENERIC SIGNAL ITEM TMC MODIFICATIONS | LUMP | LUMP | 20,836.00 |
| 0128 | 7985000000-N GENERIC SIGNAL ITEM TRAINING | LUMP | LUMP | 50,000.00 |
| 0129 | 7990000000-E GENERIC SIGNAL ITEM AERIAL CABLE PROTECTOR | 880.000 LF | 5.97000 | 5,253.60 |
| 0130 | 7990000000-E GENERIC SIGNAL ITEM ETHERNET CABLE | 675.000 LF | 11.05000 | 7,458.75 |
| 0131 | 7990000000-E GENERIC SIGNAL ITEM PLENUM-RATED COMMUNICATIONS CABLE (24 FIBER) | 300.000 LF | 11.05000 | 3,315.00 |
| 0132 | 7990000000-E GENERIC SIGNAL ITEM UNDERGROUND CONDUIT (1, 2") | 1,965.000 LF | 6.57000 | 12,910.05 |
| 0133 | 7990000000-E GENERIC SIGNAL ITEM UNDERGROUND CONDUIT (2, 2") | 42,390.000 LF | 7.83000 | 331,913.70 |

Contract ID: C203953

Project(s): STP-1302(069)

Letting Date: 04-18-17 Call Order: 007

Bidder: 3560 - Brooks-Berry-Haynie & Associates, Inc.

| Line No. | Item Description | Approx. Quantity and Units | Unit Price Dollars Cts | Bid Amount Dollars Ct |
|--------------------|---|----------------------------|--------------------------|-------------------------|
| 0134 | 7990000000-E GENERIC SIGNAL ITEM WALL-MOUNTED CONDUIT (1.25") | 1,065.000 LF | 21.15000 | 22,524.75 |
| 0135 | 7991000000-E GENERIC SIGNAL ITEM BRICK PAVERS | 100.000 SF | 40.08000 | 4,008.00 |
| Section 0001 Total | | | | 10,649,690.08 |
| Bid Total | | | | 10,649,690.08 |

NON-COLLUSION AND DEBARMENT CERTIFICATION

The bidder certifies that neither he, nor any official, agent or employee of the bidder has entered into any agreement, participated in any collusion, or otherwise taken any action which is in restraint of free competitive bidding in connection with this bid, and that the bidder intends to do the work with its own bonafide employees or subcontractors and is not bidding for the benefit of another contractor. In addition, submitting this electronic bid constitutes the bidder's certification of Status under penalty of perjury under the laws of the United States and in accordance with the Debarment Certification on file with the Department.

By submitting this bid, the bidder certifies to the best of his knowledge and belief that he and his principals:

- a. Are not presently debarred, suspended, proposed for debarment, declared ineligible, or voluntarily excluded from covered transactions by any Federal department or agency;
- b. Have not within a three-year period preceding this proposal been convicted of or had a civil judgment rendered against them for commission of fraud or a criminal offense in connection with obtaining, attempting to obtain, or performing a public (Federal, State or local) transaction or contract under a public transaction; violation of Federal or State antitrust statutes or commission of embezzlement, theft, forgery, bribery, falsification or destruction of records; making false statements; or receiving stolen property;
- c. Are not presently indicted for or otherwise criminally or civilly charged by a governmental entity (Federal, State or local) with commission of any of the offenses enumerated in paragraph b. of this certification; and
- d. Have not within a three-year period preceding this proposal had one or more public transactions (Federal, State or local) terminated for cause or default.

Where the prospective bidder is unable to certify to any of the statements in this certification, the bidder shall submit an explanation in the blanks provided herein. The explanation will not necessarily result in denial of participation in a contract.

Explanation:
NOT ANSWERED
NOT ANSWERED
NOT ANSWERED
NOT ANSWERED

If the prequalified bidder's status changes, he shall immediately submit a new fully executed non-collusion affidavit and debarment certification with an explanation of the change to the Contract Office prior to submitting the bid.

Failure to furnish a certification or an explanation will be grounds for rejection of a bid

AWARD LIMITS ON MULTIPLE PROJECTS

By answering YES to this statement, the bidder acknowledges that they are using the award limits on multiple projects. No

A bidder who desires to bid on more than one project on which bids are to be opened on the same date, and who also desires to avoid receiving an award of more projects than he is equipped to handle, may bid on any number of projects but may limit the total amount of work awarded to him on selected projects by completing the AWARD LIMITS ON MULTIPLE PROJECTS.

The Award Limits on Multiple Projects must be filled in on each project bid for which the Bidder desires protection.

It is the desire of the Bidder to be awarded contracts, the value of which will not exceed a total of NOT ANSWERED for those projects indicated herein, for which bids will be opened on (MM/DD/YY)

The Award Limits shall apply to the following projects:

| Contract Number | County |
|-----------------|--------|
| NOT ANSWERED | |
| NOT ANSWERED | |
| NOT ANSWERED | |
| NOT ANSWERED | |
| NOT ANSWERED | |
| NOT ANSWERED | |

It is agreed that if I am (we are) the low Bidder(s) on indicated projects, the total value of which is more than the above stipulated award limits, the Board of Transportation will award me (us) projects from among those indicated that have a total value not to exceed the award limit and will result in the lowest total bids to the Department of Transportation.

THIS PROPOSAL CONTAINS THE FOLLOWING ERRORS/WARNINGS (IF ANY)

This Bid contains 0 amendment files

Electronic Bid Submission

By submitting this bid electronically, I hereby acknowledge that all requirements included in the hard copy proposal, addendum, amendments, plans, standard specifications, supplemental specifications and special provisions are part of the bid and contract. Further, I acknowledge that I have read, understand, accept, acknowledge and agree to comply with all statements in this electronic bid.

I Hereby certify that I have the authority to submit this bid.

Signature

Agency

Date

| Line # | ItemNumber | Sec # | Description | Quantity Unit | Unit Bid Price | Amount Bid |
|----------------------|--------------|-------|---|----------------|----------------|------------|
| ROADWAY ITEMS | | | | | | |
| 0001 | 0000100000-N | 800 | MOBILIZATION | Lump Sum LS | 215,000.00 | 215,000.00 |
| 0002 | 2738000000-E | SP | GENERIC PAVING ITEM 4" CONCRETE SIDEWALK | 25 SY | 178.40 | 4,460.00 |
| 0003 | 4405000000-E | 1110 | WORK ZONE SIGNS (PORTABLE) | 840 SF | 132.00 | 110,880.00 |
| 0004 | 4410000000-E | 1110 | WORK ZONE SIGNS (BARRICADE MOUNTED) | 72 SF | 100.50 | 7,236.00 |
| 0005 | 4415000000-N | 1115 | FLASHING ARROW BOARD | 3 EA | 6,538.00 | 19,614.00 |
| 0006 | 4420000000-N | 1120 | PORTABLE CHANGEABLE MESSAGE SIGN | 3 EA | 13,740.00 | 41,220.00 |
| 0007 | 4430000000-N | 1130 | DRUMS | 150 EA | 190.00 | 28,500.00 |
| 0008 | 4435000000-N | 1135 | CONES | 150 EA | 136.00 | 20,400.00 |
| 0009 | 4445000000-E | 1145 | BARRICADES (TYPE III) | 50 LF | 271.00 | 13,550.00 |
| 0010 | 4450000000-N | 1150 | FLAGGER | 400 HR | 49.60 | 19,840.00 |
| 0011 | 4480000000-N | 1165 | TMA | 3 EA | 54,786.00 | 164,358.00 |
| 0012 | 4510000000-N | SP | LAW ENFORCEMENT | 450 HR | 60.25 | 27,112.50 |
| 0013 | 4516000000-N | 1180 | SKINNY DRUM | 100 EA | 11.90 | 1,190.00 |
| 0014 | 4697000000-E | 1205 | THERMOPLASTIC PAVEMENT MARKING LINES (8", 120 MILS) | 290 LF | 4.82 | 1,397.80 |
| 0015 | 4710000000-E | 1205 | THERMOPLASTIC PAVEMENT MARKING LINES (24", 120 MILS) | 740 LF | 18.08 | 13,379.20 |
| 0016 | 4870000000-E | 1205 | REMOVAL OF PAVEMENT MARKING LINES (24") | 12 LF | 12.05 | 144.60 |
| 0017 | 7048500000-E | 1705 | PEDESTRIAN SIGNAL HEAD (16", 1 SECTION W/COUNTDOWN) | 46 EA | 450.00 | 20,700.00 |
| 0018 | 7060000000-E | 1705 | SIGNAL CABLE | 56,220 LF | 1.55 | 87,141.00 |
| 0019 | 7120000000-E | 1705 | VEHICLE SIGNAL HEAD (12", 3 SECTION) | 159 EA | 656.25 | 104,343.75 |

| Line # | ItemNumber | Sec # | Description | Quantity Unit | Unit Bid Price | Amount Bid |
|--------|--------------|-------|--|---------------|----------------|------------|
| 0020 | 7132000000-E | 1705 | VEHICLE SIGNAL HEAD (12", 4 SECTION) | 110 EA | 818.00 | 89,980.00 |
| 0021 | 7144000000-E | 1705 | VEHICLE SIGNAL HEAD (12", 5 SECTION) | 6 EA | 1,091.00 | 6,546.00 |
| 0022 | 7229000000-N | SP | APS DETECTOR STATION | 30 EA | 817.00 | 24,510.00 |
| 0023 | 7230000000-N | SP | CENTRAL CONTROL UNIT APS DETECTOR STATION | 4 EA | 2,998.00 | 11,992.00 |
| 0024 | 7252000000-E | 1710 | MESSENGER CABLE (1/4") | 243,940 LF | 2.11 | 514,713.40 |
| 0025 | 7264000000-E | 1710 | MESSENGER CABLE (3/8") | 970 LF | 7.50 | 7,275.00 |
| 0026 | 7279000000-E | 1715 | TRACER WIRE | 113,700 LF | 0.45 | 51,165.00 |
| 0027 | 7301000000-E | 1715 | DIRECTIONAL DRILL (***** (1, 2")) | 830 LF | 11.15 | 9,254.50 |
| 0028 | 7301000000-E | 1715 | DIRECTIONAL DRILL (***** (2, 2")) | 41,320 LF | 14.15 | 584,678.00 |
| 0029 | 7312000000-N | 1716 | JUNCTION BOX (***** (SPECIAL-SIZED) | 81 EA | 718.00 | 58,158.00 |
| 0030 | 7324000000-N | 1716 | JUNCTION BOX (STANDARD SIZE) | 31 EA | 271.00 | 8,401.00 |
| 0031 | 7348000000-N | 1716 | JUNCTION BOX (OVER-SIZED, HEAVY DUTY) | 355 EA | 754.00 | 267,670.00 |
| 0032 | 7360000000-N | 1720 | WOOD POLE | 5 EA | 1,193.00 | 5,965.00 |
| 0033 | 7372000000-N | 1721 | GUY ASSEMBLY | 507 EA | 331.50 | 168,070.50 |
| 0034 | 7384000000-E | 1722 | **** RISER WITH ***** (1", HEAT SHRINK TUBING) | 5 EA | 562.00 | 2,810.00 |
| 0035 | 7384000000-E | 1722 | **** RISER WITH ***** (1.25", HEAT SHRINK TUBING) | 25 EA | 774.00 | 19,350.00 |
| 0036 | 7396000000-E | 1722 | 1/2" RISER WITH WEATHERHEAD | 8 EA | 328.00 | 2,624.00 |
| 0037 | 7408000000-E | 1722 | 1" RISER WITH WEATHERHEAD | 27 EA | 481.00 | 12,987.00 |
| 0038 | 7420000000-E | 1722 | 2" RISER WITH WEATHERHEAD | 50 EA | 1,045.00 | 52,250.00 |

| Line # | ItemNumber | Sec # | Description | Quantity Unit | Unit Bid Price | Amount Bid |
|--------|--------------|-------|---|---------------|----------------|------------|
| 0039 | 7430000000-N | 1722 | HEAT SHRINK TUBING RETROFIT KIT | 142 EA | 217.00 | 30,814.00 |
| 0040 | 7432000000-E | 1722 | 2" RISER WITH HEAT SHRINK TUBING | 197 EA | 1,126.00 | 221,822.00 |
| 0041 | 7444000000-E | 1725 | INDUCTIVE LOOP SAWCUT | 1,336 LF | 6.63 | 8,857.68 |
| 0042 | 7456000000-E | 1726 | LEAD-IN CABLE (*****) (14-2) | 28,200 LF | 1.48 | 41,736.00 |
| 0043 | 7516000000-E | 1730 | COMMUNICATIONS CABLE (**FIBER) (24) | 313,780 LF | 1.46 | 458,118.80 |
| 0044 | 7516000000-E | 1730 | COMMUNICATIONS CABLE (**FIBER) (60) | 131,710 LF | 1.77 | 233,126.70 |
| 0045 | 7516000000-E | 1730 | COMMUNICATIONS CABLE (**FIBER) (96) | 55,880 LF | 2.06 | 115,112.80 |
| 0046 | 7528000000-E | 1730 | DROP CABLE | 79,610 LF | 1.75 | 139,317.50 |
| 0047 | 7540000000-N | 1731 | SPLICE ENCLOSURE | 237 EA | 995.00 | 235,815.00 |
| 0048 | 7552000000-N | 1731 | INTERCONNECT CENTER | 265 EA | 904.00 | 239,560.00 |
| 0049 | 7566000000-N | 1733 | DELINEATOR MARKER | 108 EA | 54.25 | 5,859.00 |
| 0050 | 7575142200-N | SP | NEW ELECTRICAL SERVICE | 32 EA | 2,689.00 | 86,048.00 |
| 0051 | 7575160000-E | 1734 | REMOVE EXISTING COMMUNICATIONS CABLE | 20,990 LF | 0.90 | 18,891.00 |
| 0052 | 7575180000-N | 1735 | CABLE TRANSFER | 10 EA | 91.00 | 910.00 |
| 0053 | 7636000000-N | 1745 | SIGN FOR SIGNALS | 10 EA | 320.00 | 3,200.00 |
| 0054 | 7642100000-N | 1743 | TYPE I POST WITH FOUNDATION | 22 EA | 1,476.00 | 32,472.00 |
| 0055 | 7642200000-N | 1743 | TYPE II PEDESTAL WITH FOUNDATION | 4 EA | 2,015.00 | 8,060.00 |
| 0056 | 7648000000-N | 1746 | RELOCATE EXISTING SIGN | 1 EA | 107.00 | 107.00 |
| 0057 | 7684000000-N | 1750 | SIGNAL CABINET FOUNDATION | 5 EA | 5,504.00 | 27,520.00 |

| Line # | ItemNumber | Sec # | Description | Quantity Unit | Unit Bid Price | Amount Bid |
|--------|--------------|-------|--|---------------|----------------|------------|
| 0058 | 7686000000-N | 1752 | CONDUIT ENTRANCE INTO EXISTING FOUNDATION | 35 EA | 754.00 | 26,390.00 |
| 0059 | 7687000000-N | 1752 | MODIFY FOUNDATION FOR CONTROLLER CABINET | 3 EA | 151.00 | 453.00 |
| 0060 | 7696000000-N | 1751 | CONTROLLER WITH CABINET (*****) (2070E, 332, BASE MOUNTED) | 5 EA | 10,431.00 | 52,155.00 |
| 0061 | 7696000000-N | 1751 | CONTROLLER WITH CABINET (*****) (2070E, 336S BASE MOUNTED) | 25 EA | 9,875.00 | 246,875.00 |
| 0062 | 7696000000-N | 1751 | CONTROLLER WITH CABINET (*****) (2070E, 336S POLE MOUNTED) | 34 EA | 11,492.00 | 390,728.00 |
| 0063 | 7708000000-N | 1751 | DETECTOR CARD (*****) (MODEL 222) | 1,613 EA | 103.00 | 166,139.00 |
| 0064 | 7901000000-N | 1753 | CABINET BASE EXTENDER | 50 EA | 335.00 | 16,750.00 |
| 0065 | 7901010000-N | 1753 | CABINET BASE ADAPTER | 3 EA | 515.00 | 1,545.00 |
| 0066 | 7980000000-N | SP | GENERIC SIGNAL ITEM 2.4 GHZ ETHERNET RADIO | 4 EA | 4,502.00 | 18,008.00 |
| 0067 | 7980000000-N | SP | GENERIC SIGNAL ITEM 5/8" X 10' GROUNDING ELECTRODE | 128 EA | 366.00 | 46,848.00 |
| 0068 | 7980000000-N | SP | GENERIC SIGNAL ITEM 900 MHZ ETHERNET RADIO | 34 EA | 6,374.00 | 216,716.00 |
| 0069 | 7980000000-N | SP | GENERIC SIGNAL ITEM CCTV CABINET | 16 EA | 5,766.00 | 92,256.00 |
| 0070 | 7980000000-N | SP | GENERIC SIGNAL ITEM CCTV CABINET DISCONNECT | 2 EA | 340.00 | 680.00 |
| 0071 | 7980000000-N | SP | GENERIC SIGNAL ITEM CCTV CAMERA ASSEMBLY | 29 EA | 3,865.00 | 112,085.00 |
| 0072 | 7980000000-N | SP | GENERIC SIGNAL ITEM CCTV TEST CABINET | 1 EA | 3,038.00 | 3,038.00 |
| 0073 | 7980000000-N | SP | GENERIC SIGNAL ITEM CCTV WOOD POLE | 14 EA | 3,635.00 | 50,890.00 |

Contract Item Sheets For C203953

| Line # | ItemNumber | Sec # | Description | Quantity Unit | Unit Bid Price | Amount Bid |
|--------|--------------|-------|--|---------------|----------------|--------------|
| 0074 | 7980000000-N | SP | GENERIC SIGNAL ITEM COMMUNICATIONS RACK | 2 EA | 2,893.00 | 5,786.00 |
| 0075 | 7980000000-N | SP | GENERIC SIGNAL ITEM COMPUTER WORKSTATION | 4 EA | 3,156.00 | 12,624.00 |
| 0076 | 7980000000-N | SP | GENERIC SIGNAL ITEM CONTROLLER WITH CABINET & AUX FILE (2070E, 332, BASE MOUNT- ED) | 212 EA | 11,835.00 | 2,509,020.00 |
| 0077 | 7980000000-N | SP | GENERIC SIGNAL ITEM DIGITAL DISPLAY MONITOR | 3 EA | 1,972.00 | 5,916.00 |
| 0078 | 7980000000-N | SP | GENERIC SIGNAL ITEM ETHERNET CORE SWITCH | 1 EA | 58,000.00 | 58,000.00 |
| 0079 | 7980000000-N | SP | GENERIC SIGNAL ITEM ETHERNET EDGE SWITCH | 291 EA | 1,223.50 | 356,038.50 |
| 0080 | 7980000000-N | SP | GENERIC SIGNAL ITEM FIREWALL | 1 EA | 3,255.00 | 3,255.00 |
| 0081 | 7980000000-N | SP | GENERIC SIGNAL ITEM FURNISH 2.4 GHZ ETHERNET RADIO | 1 EA | 1,862.00 | 1,862.00 |
| 0082 | 7980000000-N | SP | GENERIC SIGNAL ITEM FURNISH 2018 ENHANCED CONFLICT MONITOR | 14 EA | 952.00 | 13,328.00 |
| 0083 | 7980000000-N | SP | GENERIC SIGNAL ITEM FURNISH 2070E CONTROLLER | 14 EA | 1,605.00 | 22,470.00 |
| 0084 | 7980000000-N | SP | GENERIC SIGNAL ITEM FURNISH 332 CABINET | 11 EA | 7,363.00 | 80,993.00 |
| 0085 | 7980000000-N | SP | GENERIC SIGNAL ITEM FURNISH 336S CABINET | 3 EA | 6,801.00 | 20,403.00 |
| 0086 | 7980000000-N | SP | GENERIC SIGNAL ITEM FURNISH 900 MHZ ETHERNET RADIO | 2 EA | 1,507.00 | 3,014.00 |
| 0087 | 7980000000-N | SP | GENERIC SIGNAL ITEM FURNISH CCTV CABINET | 1 EA | 2,676.00 | 2,676.00 |
| 0088 | 7980000000-N | SP | GENERIC SIGNAL ITEM FURNISH CCTV CAMERA ASSEMBLY | 2 EA | 2,893.00 | 5,786.00 |

| Line # | ItemNumber | Sec # | Description | Quantity Unit | Unit Bid Price | Amount Bid |
|--------|--------------|-------|--|---------------|----------------|------------|
| 0089 | 7980000000-N | SP | GENERIC SIGNAL ITEM FURNISH CONFLICT MONITOR TEST- ER | 2 EA | 17,347.00 | 34,694.00 |
| 0090 | 7980000000-N | SP | GENERIC SIGNAL ITEM FURNISH DETECTOR CARD (MODEL 222) | 81 EA | 76.50 | 6,196.50 |
| 0091 | 7980000000-N | SP | GENERIC SIGNAL ITEM FURNISH ETHERNET EDGE SWITCH | 15 EA | 1,164.00 | 17,460.00 |
| 0092 | 7980000000-N | SP | GENERIC SIGNAL ITEM FURNISH FIBER-OPTIC POWER METER | 2 EA | 2,580.00 | 5,160.00 |
| 0093 | 7980000000-N | SP | GENERIC SIGNAL ITEM FURNISH FIBER-OPTIC RESTORA- TION KIT | 1 EA | 3,224.00 | 3,224.00 |
| 0094 | 7980000000-N | SP | GENERIC SIGNAL ITEM FURNISH OPTICAL LIGHT GENERA- TOR | 4 EA | 3,869.00 | 15,476.00 |
| 0095 | 7980000000-N | SP | GENERIC SIGNAL ITEM FURNISH SPARE CABLE & CONNEC- TORS KIT | 1 EA | 3,224.00 | 3,224.00 |
| 0096 | 7980000000-N | SP | GENERIC SIGNAL ITEM FURNISH VIDEO MONITOR | 1 EA | 1,422.00 | 1,422.00 |
| 0097 | 7980000000-N | SP | GENERIC SIGNAL ITEM FURNISH VISUAL FAULT LOCATOR | 2 EA | 580.00 | 1,160.00 |
| 0098 | 7980000000-N | SP | GENERIC SIGNAL ITEM GUY ASSEMBLY (AERIAL) | 41 EA | 331.50 | 13,591.50 |
| 0099 | 7980000000-N | SP | GENERIC SIGNAL ITEM GUY ASSEMBLY (SIDEWALK) | 61 EA | 476.00 | 29,036.00 |
| 0100 | 7980000000-N | SP | GENERIC SIGNAL ITEM ITS SERVER | 2 EA | 18,900.00 | 37,800.00 |
| 0101 | 7980000000-N | SP | GENERIC SIGNAL ITEM KVM SWITCH | 1 EA | 3,134.00 | 3,134.00 |
| 0102 | 7980000000-N | SP | GENERIC SIGNAL ITEM LAPTOP COMPUTER | 7 EA | 3,377.00 | 23,639.00 |
| 0103 | 7980000000-N | SP | GENERIC SIGNAL ITEM MODIFY EXISTING ELECTRICAL SERVICE | 5 EA | 2,338.00 | 11,690.00 |

| Line # | ItemNumber | Sec # | Description | Quantity Unit | Unit Bid Price | Amount Bid |
|--------|--------------|-------|--|---------------|----------------|------------|
| 0104 | 7980000000-N | SP | GENERIC SIGNAL ITEM MODIFY EXISTING SPLICE | 4 EA | 1,266.00 | 5,064.00 |
| 0105 | 7980000000-N | SP | GENERIC SIGNAL ITEM MODIFY VIDEO SERVER | 1 EA | 4,339.00 | 4,339.00 |
| 0106 | 7980000000-N | SP | GENERIC SIGNAL ITEM MW VEH DET SYS - MULTI ZONE | 1 EA | 8,250.00 | 8,250.00 |
| 0107 | 7980000000-N | SP | GENERIC SIGNAL ITEM NETWORK VIDEO RECORDER | 1 EA | 8,594.00 | 8,594.00 |
| 0108 | 7980000000-N | SP | GENERIC SIGNAL ITEM POLE-MOUNT RADIO CABINET | 2 EA | 5,868.00 | 11,736.00 |
| 0109 | 7980000000-N | SP | GENERIC SIGNAL ITEM PRINTER | 1 EA | 2,650.00 | 2,650.00 |
| 0110 | 7980000000-N | SP | GENERIC SIGNAL ITEM PTZ JOYSTICK | 1 EA | 1,085.00 | 1,085.00 |
| 0111 | 7980000000-N | SP | GENERIC SIGNAL ITEM REMOVE SPLICE/HUB CABINET | 1 EA | 1,145.00 | 1,145.00 |
| 0112 | 7980000000-N | SP | GENERIC SIGNAL ITEM REMOVE SPLICE/HUB CABINET FOUNDATION | 1 EA | 701.00 | 701.00 |
| 0113 | 7980000000-N | SP | GENERIC SIGNAL ITEM SOLAR POWER ASSEMBLY | 2 EA | 9,315.00 | 18,630.00 |
| 0114 | 7980000000-N | SP | GENERIC SIGNAL ITEM SPECIAL COATING (332 CABINET) | 5 EA | 240.00 | 1,200.00 |
| 0115 | 7980000000-N | SP | GENERIC SIGNAL ITEM SPECIAL COATING (336 CABINET) | 2 EA | 240.00 | 480.00 |
| 0116 | 7980000000-N | SP | GENERIC SIGNAL ITEM SPECIAL COATING (BASE EXTENDER /ADAPTER) | 5 EA | 240.00 | 1,200.00 |
| 0117 | 7980000000-N | SP | GENERIC SIGNAL ITEM SURFACE MOUNTED JUNCTION BOX | 4 EA | 1,163.00 | 4,652.00 |
| 0118 | 7980000000-N | SP | GENERIC SIGNAL ITEM TERMINAL SPLICE CABINET | 1 EA | 1,748.00 | 1,748.00 |
| 0119 | 7980000000-N | SP | GENERIC SIGNAL ITEM TEST CONTROLLER WITH CABINET | 1 EA | 13,027.00 | 13,027.00 |

Contract Item Sheets For C203953

| Line # | ItemNumber | Sec # | Description | Quantity Unit | Unit Bid Price | Amount Bid |
|--------|--------------|-------|--|----------------|----------------|------------|
| 0120 | 7980000000-N | SP | GENERIC SIGNAL ITEM UPS (TMC) | 1 EA | 4,339.00 | 4,339.00 |
| 0121 | 7985000000-N | SP | GENERIC SIGNAL ITEM CITY HALL MODIFICATIONS | Lump Sum LS | 21,140.00 | 21,140.00 |
| 0122 | 7985000000-N | SP | GENERIC SIGNAL ITEM DIVISION 13 OFFICE MODIFICA- TIONS | Lump Sum LS | 13,712.00 | 13,712.00 |
| 0123 | 7985000000-N | SP | GENERIC SIGNAL ITEM MODIFY CCTV SOFTWARE | Lump Sum LS | 5,062.00 | 5,062.00 |
| 0124 | 7985000000-N | SP | GENERIC SIGNAL ITEM NETWORK MANAGEMENT SOFTWARE | Lump Sum LS | 20,250.00 | 20,250.00 |
| 0125 | 7985000000-N | SP | GENERIC SIGNAL ITEM SIGNAL SYSTEM SOFTWARE | Lump Sum LS | 585,000.00 | 585,000.00 |
| 0126 | 7985000000-N | SP | GENERIC SIGNAL ITEM SYSTEM SUPPORT SOFTWARE AND DEVICES | Lump Sum LS | 1,618.00 | 1,618.00 |
| 0127 | 7985000000-N | SP | GENERIC SIGNAL ITEM TMC MODIFICATIONS | Lump Sum LS | 20,836.00 | 20,836.00 |
| 0128 | 7985000000-N | SP | GENERIC SIGNAL ITEM TRAINING | Lump Sum LS | 50,000.00 | 50,000.00 |
| 0129 | 7990000000-E | SP | GENERIC SIGNAL ITEM AERIAL CABLE PROTECTOR | 880 LF | 5.97 | 5,253.60 |
| 0130 | 7990000000-E | SP | GENERIC SIGNAL ITEM ETHERNET CABLE | 675 LF | 11.05 | 7,458.75 |
| 0131 | 7990000000-E | SP | GENERIC SIGNAL ITEM PLENUM-RATED COMMUNICATIONS CABLE (24 FIBER) | 300 LF | 11.05 | 3,315.00 |
| 0132 | 7990000000-E | SP | GENERIC SIGNAL ITEM UNDERGROUND CONDUIT (1, 2") | 1,965 LF | 6.57 | 12,910.05 |
| 0133 | 7990000000-E | SP | GENERIC SIGNAL ITEM UNDERGROUND CONDUIT (2, 2") | 42,390 LF | 7.83 | 331,913.70 |
| 0134 | 7990000000-E | SP | GENERIC SIGNAL ITEM WALL-MOUNTED CONDUIT (1.25") | 1,065 LF | 21.15 | 22,524.75 |

Contract Item Sheets For C203953

| Line # | ItemNumber | Sec # | Description | Quantity Unit | Unit Bid Price | Amount Bid |
|--------|--------------|-------|-------------------------------------|---------------|----------------|------------|
| 0135 | 7991000000-E | SP | GENERIC SIGNAL ITEM BRICK PAVERS | 100 SF | 40.08 | 4,008.00 |

TOTAL AMOUNT OF BID FOR ENTIRE PROJECT **\$10,649,690.08**

1407/May01/Q1144458/D990155392200/E135

Contract No. C203953
County BUNCOMBE

Rev. 5-19-11

**EXECUTION OF CONTRACT
NON-COLLUSION AFFIDAVIT, DEBARMENT CERTIFICATION AND GIFT BAN CERTIFICATION**

CORPORATION

The Contractor being duly sworn, solemnly swears (or affirms) that neither he, nor any official, agent or employee has entered into any agreement, participated in any collusion, or otherwise taken any action which is in restraint of free competitive bidding in connection with this Contract, that the Contractor has not been convicted of violating N.C.G.S. § 133-24 within the last three years, and that the Contractor intends to do the work with its own bonafide employees or subcontractors and did not bid for the benefit of another contractor.

By submitting this Execution of Contract, Non-Collusion Affidavit and Debarment Certification, the Contractor is certifying his status under penalty of perjury under the laws of the United States in accordance with the Debarment Certification attached, provided that the Debarment Certification also includes any required statements concerning exceptions that are applicable.

N.C.G.S. § 133-32 and Executive Order 24 prohibit the offer to, or acceptance by, any State Employee of any gift from anyone with a contract with the State, or from any person seeking to do business with the State. By execution of any response in this procurement, you attest, for your entire organization and its employees or agents, that you are not aware that any such gift has been offered, accepted, or promised by any employees of your organization.

SIGNATURE OF CONTRACTOR

Brooks-Berry-Haynie & Associates, Inc.

Full name of Corporation

Brooks-Berry-Haynie & Associates, Inc.

600 Discovery Place

Mableton, GA 30126

Address as Prequalified

Attest Tim B. McCarty
Secretary/Assistant Secretary
Select appropriate title

By Jason Owen
President/Vice President/Assistant Vice President.
Select appropriate title

TIM B. MCCARTY
Print or type Signer's name

JASON OWEN
Print or type Signer's name

CORPORATE SEAL

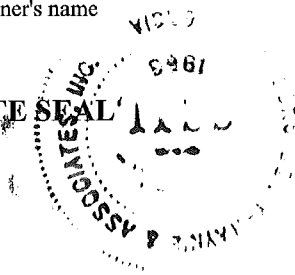

AFFIDAVIT MUST BE NOTARIZED

Subscribed and sworn to before me this the

10 day of May 2017.

Julian Cuzelis
Signature of Notary Public

NOTARY SEAL

of COBB County

State of GEORGIA

My Commission Expires: April 19, 2021

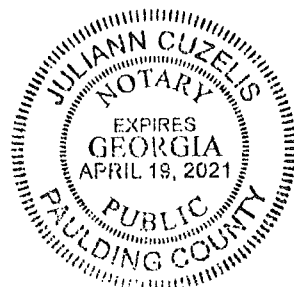

DEBARMENT CERTIFICATION

Conditions for certification:

1. The prequalified bidder shall provide immediate written notice to the Department if at any time the bidder learns that his certification was erroneous when he submitted his debarment certification or explanation filed with the Department, or has become erroneous because of changed circumstances.
2. The terms *covered transaction, debarred, suspended, ineligible, lower tier covered transaction, participant, person, primary covered transaction, principal, proposal, and voluntarily excluded*, as used in this provision, have the meanings set out in the Definitions and Coverage sections of the rules implementing Executive Order 12549. A copy of the Federal Rules requiring this certification and detailing the definitions and coverages may be obtained from the Contract Officer of the Department.
3. The prequalified bidder agrees by submitting this form, that he will not knowingly enter into any lower tier covered transaction with a person who is debarred, suspended, declared ineligible, or voluntarily excluded from participation in NCDOT contracts, unless authorized by the Department.
4. For Federal Aid projects, the prequalified bidder further agrees that by submitting this form he will include the Federal-Aid Provision titled *Required Contract Provisions Federal-Aid Construction Contract (Form FHWA PR 1273)* provided by the Department, without subsequent modification, in all lower tier covered transactions.
5. The prequalified bidder may rely upon a certification of a participant in a lower tier covered transaction that he is not debarred, suspended, ineligible, or voluntarily excluded from the covered transaction, unless he knows that the certification is erroneous. The bidder may decide the method and frequency by which he will determine the eligibility of his subcontractors.
6. Nothing contained in the foregoing shall be construed to require establishment of a system of records in order to render in good faith the certification required by this provision. The knowledge and information of a participant is not required to exceed that which is normally possessed by a prudent person in the ordinary course of business dealings.
7. Except as authorized in paragraph 6 herein, the Department may terminate any contract if the bidder knowingly enters into a lower tier covered transaction with a person who is suspended, debarred, ineligible, or voluntarily excluded from participation in this transaction, in addition to other remedies available by the Federal Government.

Contract No. C203953
County BOWCOMBE

Rev. 5-19-11

DEBARMENT CERTIFICATION

The prequalified bidder certifies to the best of his knowledge and belief, that he and his principals:

- a. Are not presently debarred, suspended, proposed for debarment, declared ineligible, or voluntarily excluded from covered transactions by any Federal department or agency;
- b. Have not within a three-year period preceding this proposal been convicted of or had a civil judgment rendered against them for commission of fraud or a criminal offense in connection with obtaining, attempting to obtain, or performing a public (Federal, State or local) transaction or contract under a public transaction; violation of Federal or State antitrust statutes or commission of embezzlement, theft, forgery, bribery, falsification or destruction of records; making false statements; or receiving stolen property;
- c. Are not presently indicted for or otherwise criminally or civilly charged by a governmental entity (Federal, State or local) with commission of any of the offenses enumerated in paragraph b. of this certification; and
- d. Have not within a three-year period preceding this proposal had one or more public transactions (Federal, State or local) terminated for cause or default.
- e. Will submit a revised Debarment Certification immediately if his status changes and will show in his bid proposal an explanation for the change in status.

If the prequalified bidder cannot certify that he is not debarred, he shall provide an explanation with this submittal. An explanation will not necessarily result in denial of participation in a contract.

Failure to submit a non-collusion affidavit and debarment certification will result in the prequalified bidder's bid being considered non-responsive.

Check here if an explanation is attached to this certification.

Contract No. C203953

County (ies): Buncombe

ACCEPTED BY THE
DEPARTMENT OF TRANSPORTATION

DocuSigned by:

Ronald E. Davenport, Jr.

F81B6838A47A442...

Contract Officer

5/16/2017

Date

Execution of Contract and Bonds
Approved as to Form:

DocuSigned by:

Steve Armstrong

5C738C23AF00458...

Attorney General

5/16/2017

Date

Signature Sheet (Bid - Acceptance by Department)

Contract No C203953
County Buncombe

Rev 5-17-11

Bond No.: 016070683

CONTRACT PAYMENT BOND

Date of Payment Bond Execution 5/11/2017

Name of Principal Contractor Brooks Berry Haynie & Associates, Inc.

Name of Surety: Liberty Mutual Insurance Company

Name of Contracting Body: **North Carolina Department of Transportation**
Raleigh, North Carolina

Amount of Bond: \$10,649,690.08

Contract ID No.: C203953

County Name: Buncombe

KNOW ALL MEN BY THESE PRESENTS, That we, the PRINCIPAL CONTRACTOR (hereafter, PRINCIPAL) and SURETY above named, are held and firmly bound unto the above named Contracting Body, hereinafter called the Contracting Body, in the penal sum of the amount stated above for the payment of which sum well and truly to be made, we bind ourselves, our heirs, executors, administrators, and successors, jointly and severally, firmly by these presents.

THE CONDITION OF THIS OBLIGATION IS SUCH, that whereas the principal entered into a certain contract with the Contracting Body, numbered as shown above and hereto attached:

NOW THEREFORE, if the principal shall promptly make payment to all persons supplying labor and material in the prosecution of the work provided for in said contract, and any and all duly authorized modifications of said contract that may hereafter be made, notice of which modifications to the surety being hereby waived, then this obligation to be void; otherwise to remain in full force and virtue.

IN WITNESS WHEREOF, the above-bound parties have executed this instrument under their several seals on the date indicated above, the name and corporate seal of each corporate party being hereto affixed and these presents duly signed by its undersigned representative, pursuant to authority of its governing body.

Contract No. C203953
County Buncombe

Rev 5-17-11

CONTRACT PAYMENT BOND

Affix Seal of Surety Company

Liberty Mutual Insurance Company
Print or type Surety Company Name

By W. Parker Hix
Print, stamp or type name of Attorney-in-Fact

WPH

Signature of Attorney-in-Fact

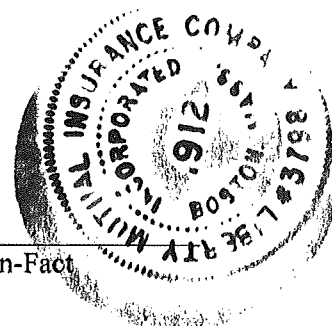

Carrie J. Key
Signature of Witness

Carrie J. Key
Print or type Signer's name

PentaRisk Associates of Georgia, LLC
3715 Northside Parkway, Bldg 400, Suite 550
Atlanta, GA 30327
Address of Attorney-in-Fact

Contract No C203953
County Buncombe

Rev 5-17-11

CONTRACT PAYMENT BOND

CORPORATION

SIGNATURE OF CONTRACTOR (Principal)

Brooks Berry Haynie & Associates, Inc.
Full name of Corporation

600 Discovery Place, Mableton, GA 30126
Address as prequalified

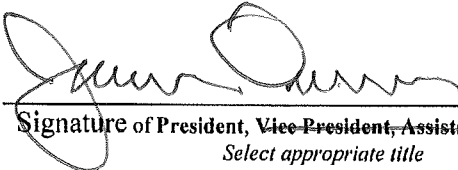
By 
Signature of President, ~~Vice President~~, ~~Assistant Vice President~~
Select appropriate title

Jason Owen
Print or type Signer's name

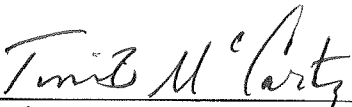

Affix Corporate Seal

Attest 
Signature of Secretary, ~~Assistant Secretary~~
Select appropriate title

Tim B. McCarty
Print or type Signer's name

Contract No
County

C203953

Buncombe

Rev 5-17-11

CONTRACT PAYMENT BOND

Attach certified copy of Power of Attorney to this sheet

THIS POWER OF ATTORNEY IS NOT VALID UNLESS IT IS PRINTED ON RED BACKGROUND.

This Power of Attorney limits the acts of those named herein, and they have no authority to bind the Company except in the manner and to the extent herein stated.

Certificate No. 7084664

American Fire and Casualty Company
The Ohio Casualty Insurance Company

Liberty Mutual Insurance Company
West American Insurance Company

POWER OF ATTORNEY

KNOWN ALL PERSONS BY THESE PRESENTS: That American Fire & Casualty Company and The Ohio Casualty Insurance Company are corporations duly organized under the laws of the State of New Hampshire, that Liberty Mutual Insurance Company is a corporation duly organized under the laws of the State of Massachusetts, and West American Insurance Company is a corporation duly organized under the laws of the State of Indiana (herein collectively called the "Companies"), pursuant to and by authority herein set forth, does hereby name, constitute and appoint, David C. Eades; Nathalie Desrosiers; W. Parker Hix

all of the city of Atlanta, state of GA each individually if there be more than one named, its true and lawful attorney-in-fact to make, execute, seal, acknowledge and deliver, for and on its behalf as surety and as its act and deed, any and all undertakings, bonds, recognizances and other surety obligations, in pursuance of these presents and shall be as binding upon the Companies as if they have been duly signed by the president and attested by the secretary of the Companies in their own proper persons.

IN WITNESS WHEREOF, this Power of Attorney has been subscribed by an authorized officer or official of the Companies and the corporate seals of the Companies have been affixed thereto this 13th day of August, 2015.

American Fire and Casualty Company
The Ohio Casualty Insurance Company
Liberty Mutual Insurance Company
West American Insurance Company

By: David M. Carey
David M. Carey, Assistant Secretary

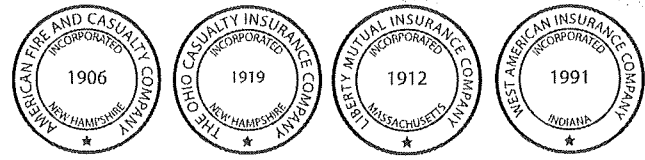

STATE OF PENNSYLVANIA ss
COUNTY OF MONTGOMERY

On this 13th day of August, 2015, before me personally appeared David M. Carey, who acknowledged himself to be the Assistant Secretary of American Fire and Casualty Company, Liberty Mutual Insurance Company, The Ohio Casualty Insurance Company, and West American Insurance Company, and that he, as such, being authorized so to do, execute the foregoing instrument for the purposes therein contained by signing on behalf of the corporations by himself as a duly authorized officer.

IN WITNESS WHEREOF, I have hereunto subscribed my name and affixed my notarial seal at Plymouth Meeting, Pennsylvania, on the day and year first above written.



COMMONWEALTH OF PENNSYLVANIA
Notarial Seal
Teresa Pastella, Notary Public
Plymouth Twp., Montgomery County
My Commission Expires March 28, 2017
Member, Pennsylvania Association of Notaries

By: Teresa Pastella
Teresa Pastella, Notary Public

This Power of Attorney is made and executed pursuant to and by authority of the following By-laws and Authorizations of American Fire and Casualty Company, The Ohio Casualty Insurance Company, Liberty Mutual Insurance Company, and West American Insurance Company which resolutions are now in full force and effect reading as follows:

ARTICLE IV – OFFICERS – Section 12. Power of Attorney. Any officer or other official of the Corporation authorized for that purpose in writing by the Chairman or the President, and subject to such limitation as the Chairman or the President may prescribe, shall appoint such attorneys-in-fact, as may be necessary to act in behalf of the Corporation to make, execute, seal, acknowledge and deliver as surety any and all undertakings, bonds, recognizances and other surety obligations. Such attorneys-in-fact, subject to the limitations set forth in their respective powers of attorney, shall have full power to bind the Corporation by their signature and execution of any such instruments and to attach thereto the seal of the Corporation. When so executed, such instruments shall be as binding as if signed by the President and attested to by the Secretary. Any power or authority granted to any representative or attorney-in-fact under the provisions of this article may be revoked at any time by the Board, the Chairman, the President or by the officer or officers granting such power or authority.

ARTICLE XIII – Execution of Contracts – SECTION 5. Surety Bonds and Undertakings. Any officer of the Company authorized for that purpose in writing by the chairman or the president, and subject to such limitations as the chairman or the president may prescribe, shall appoint such attorneys-in-fact, as may be necessary to act in behalf of the Company to make, execute, seal, acknowledge and deliver as surety any and all undertakings, bonds, recognizances and other surety obligations. Such attorneys-in-fact subject to the limitations set forth in their respective powers of attorney, shall have full power to bind the Company by their signature and execution of any such instruments and to attach thereto the seal of the Company. When so executed such instruments shall be as binding as if signed by the president and attested by the secretary.

Certificate of Designation – The President of the Company, acting pursuant to the Bylaws of the Company, authorizes David M. Carey, Assistant Secretary to appoint such attorneys-in-fact as may be necessary to act on behalf of the Company to make, execute, seal, acknowledge and deliver as surety any and all undertakings, bonds, recognizances and other surety obligations.

Authorization – By unanimous consent of the Company's Board of Directors, the Company consents that facsimile or mechanically reproduced signature of any assistant secretary of the Company, wherever appearing upon a certified copy of any power of attorney issued by the Company in connection with surety bonds, shall be valid and binding upon the Company with the same force and effect as though manually affixed.

I, Gregory W. Davenport, the undersigned, Assistant Secretary, of American Fire and Casualty Company, The Ohio Casualty Insurance Company, Liberty Mutual Insurance Company, and West American Insurance Company do hereby certify that the original power of attorney of which the foregoing is a full, true and correct copy of the Power of Attorney executed by said Companies, is in full force and effect and has not been revoked.

IN TESTIMONY WHEREOF, I have hereunto set my hand and affixed the seals of said Companies this 13th day of May, 2017.

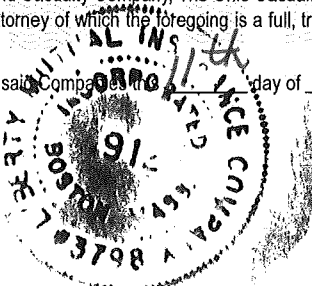
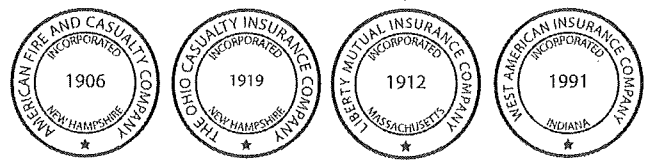

By: Gregory W. Davenport
Gregory W. Davenport, Assistant Secretary

Not valid for mortgage, note, loan, letter of credit, currency rate, interest rate or residual value guarantees.

To confirm the validity of this Power of Attorney call 1-610-832-8240 between 9:00 am and 4:30 pm EST on any business day.

Contract No. C203953
County Buncombe

Rev 5-17-11

Bond No.: 016070683

CONTRACT PERFORMANCE BOND

Date of Performance Bond Execution: 5/11/2017

Name of Principal Contractor: Brooks Berry Haynie & Associates, Inc.

Name of Surety: Liberty Mutual Insurance Company

Name of Contracting Body: **North Carolina Department of Transportation**
Raleigh, North Carolina

Amount of Bond: \$10,649,690.08

Contract ID No.: C203953

County Name: Buncombe

KNOW ALL MEN BY THESE PRESENTS, That we, the PRINCIPAL CONTRACTOR (hereafter, PRINCIPAL) and SURETY above named, are held and firmly bound unto the above named Contracting Body, hereinafter called the Contracting Body, in the penal sum of the amount stated above for the payment of which sum well and truly to be made, we bind ourselves, our heirs, executors, administrators, and successors, jointly and severally, firmly by these presents.

THE CONDITION OF THIS OBLIGATION IS SUCH, that whereas the principal entered into a certain contract with the Contracting Body, numbered as shown above and hereto attached:

NOW THEREFORE, if the principal shall well and truly perform and fulfill all the undertakings, covenants, terms, conditions, and agreements of said contract during the original term of said contract and any extensions thereof that may be granted by the Contracting Body, with or without notice to the Surety, and during the life of any guaranty required under the contract, and shall also well and truly perform and fulfill all the undertakings, covenants, terms, conditions, and agreements of any and all duly authorized modifications of said contract that may hereafter be made, notice of which modifications to the surety being hereby waived, then this obligation to be void; otherwise to remain in full force and virtue.

IN WITNESS WHEREOF, the above-bound parties have executed this instrument under their several seals on the date indicated above, the name and corporate seal of each corporate party being hereto affixed and these presents duly signed by its undersigned representative, pursuant to authority of its governing body.

Contract No.
County

C203953
Buncombe

Rev 5-17-11

CONTRACT PERFORMANCE BOND

Affix Seal of Surety Company

Liberty Mutual Insurance Company

Print or type Surety Company Name

By W. Parker Hix

Print, stamp or type name of Attorney-in-Fact

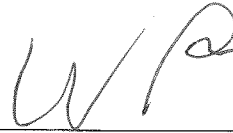

Signature of Attorney-in-Fact

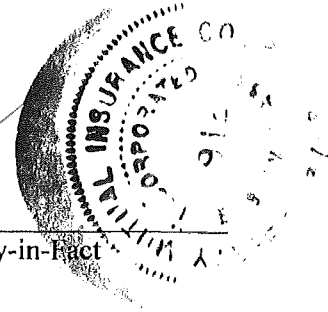

Signature of Witness

Carrie J. Key

Print or type Signer's name

PentaRisk Associates Of Georgia, LLC
3715 Northside Parkwav. Bldg 400. Suite 550
Atlanta, GA 30327

Address of Attorney-in-Fact

Contract No. C203953
County Buncombe

Rev 5-17-11

**CONTRACT PERFORMANCE BOND
CORPORATION**

SIGNATURE OF CONTRACTOR (Principal)

Brooks Berry Haynie & Associates, Inc.
Full name of Corporation

600 Discovery Place, Mableton, GA 30126
Address as prequalified

By [Signature]
Signature of President, Vice President, Assistant Vice President
Select appropriate title

Jason Owen
Print or type Signer's name



Affix Corporate Seal

Attest Tim M. Casey
Signature of Secretary, Assistant Secretary
Select appropriate title

Tim M. Casey
Print or type Signer's name

Contract No.
County

C203953
Buncombe

Rev 5-17-11

CONTRACT PERFORMANCE BOND

Attach certified copy of Power of Attorney to this sheet

THIS POWER OF ATTORNEY IS NOT VALID UNLESS IT IS PRINTED ON RED BACKGROUND.

This Power of Attorney limits the acts of those named herein, and they have no authority to bind the Company except in the manner and to the extent herein stated.

Certificate No. 7084665

American Fire and Casualty Company
The Ohio Casualty Insurance Company

Liberty Mutual Insurance Company
West American Insurance Company

POWER OF ATTORNEY

KNOWN ALL PERSONS BY THESE PRESENTS: That American Fire & Casualty Company and The Ohio Casualty Insurance Company are corporations duly organized under the laws of the State of New Hampshire, that Liberty Mutual Insurance Company is a corporation duly organized under the laws of the State of Massachusetts, and West American Insurance Company is a corporation duly organized under the laws of the State of Indiana (herein collectively called the "Companies"), pursuant to and by authority herein set forth, does hereby name, constitute and appoint, David C. Eades; Nathalie Desrosiers; W. Parker Hix

all of the city of Atlanta, state of GA each individually if there be more than one named, its true and lawful attorney-in-fact to make, execute, seal, acknowledge and deliver, for and on its behalf as surety and as its act and deed, any and all undertakings, bonds, recognizances and other surety obligations, in pursuance of these presents and shall be as binding upon the Companies as if they have been duly signed by the president and attested by the secretary of the Companies in their own proper persons.

IN WITNESS WHEREOF, this Power of Attorney has been subscribed by an authorized officer or official of the Companies and the corporate seals of the Companies have been affixed thereto this 13th day of August, 2015.

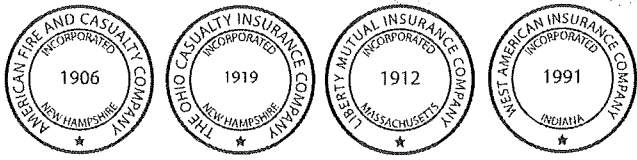

American Fire and Casualty Company
The Ohio Casualty Insurance Company
Liberty Mutual Insurance Company
West American Insurance Company

By: David M. Carey
David M. Carey, Assistant Secretary

Not valid for mortgage, note, loan, letter of credit, currency rate, interest rate or residual value guarantees.

STATE OF PENNSYLVANIA ss
COUNTY OF MONTGOMERY

On this 13th day of August, 2015, before me personally appeared David M. Carey, who acknowledged himself to be the Assistant Secretary of American Fire and Casualty Company, Liberty Mutual Insurance Company, The Ohio Casualty Insurance Company, and West American Insurance Company, and that he, as such, being authorized so to do, execute the foregoing instrument for the purposes therein contained by signing on behalf of the corporations by himself as a duly authorized officer.

IN WITNESS WHEREOF, I have hereunto subscribed my name and affixed my notarial seal at Plymouth Meeting, Pennsylvania, on the day and year first above written.



Notarial Seal
Teresa Pastella, Notary Public
Plymouth Twp., Montgomery County
My Commission Expires March 28, 2017
Member, Pennsylvania Association of Notaries

By: Teresa Pastella
Teresa Pastella, Notary Public

This Power of Attorney is made and executed pursuant to and by authority of the following By-laws and Authorizations of American Fire and Casualty Company, The Ohio Casualty Insurance Company, Liberty Mutual Insurance Company, and West American Insurance Company which resolutions are now in full force and effect reading as follows:

ARTICLE IV – OFFICERS – Section 12. Power of Attorney. Any officer or other official of the Corporation authorized for that purpose in writing by the Chairman or the President, and subject to such limitation as the Chairman or the President may prescribe, shall appoint such attorneys-in-fact, as may be necessary to act in behalf of the Corporation to make, execute, seal, acknowledge and deliver as surety any and all undertakings, bonds, recognizances and other surety obligations. Such attorneys-in-fact, subject to the limitations set forth in their respective powers of attorney, shall have full power to bind the Corporation by their signature and execution of any such instruments and to attach thereto the seal of the Corporation. When so executed, such instruments shall be as binding as if signed by the President and attested to by the Secretary. Any power or authority granted to any representative or attorney-in-fact under the provisions of this article may be revoked at any time by the Board, the Chairman, the President or by the officer or officers granting such power or authority.

ARTICLE XIII – Execution of Contracts – SECTION 5. Surety Bonds and Undertakings. Any officer of the Company authorized for that purpose in writing by the chairman or the president, and subject to such limitations as the chairman or the president may prescribe, shall appoint such attorneys-in-fact, as may be necessary to act in behalf of the Company to make, execute, seal, acknowledge and deliver as surety any and all undertakings, bonds, recognizances and other surety obligations. Such attorneys-in-fact subject to the limitations set forth in their respective powers of attorney, shall have full power to bind the Company by their signature and execution of any such instruments and to attach thereto the seal of the Company. When so executed such instruments shall be as binding as if signed by the president and attested by the secretary.

Certificate of Designation – The President of the Company, acting pursuant to the Bylaws of the Company, authorizes David M. Carey, Assistant Secretary to appoint such attorneys-in-fact as may be necessary to act on behalf of the Company to make, execute, seal, acknowledge and deliver as surety any and all undertakings, bonds, recognizances and other surety obligations.

Authorization – By unanimous consent of the Company's Board of Directors, the Company consents that facsimile or mechanically reproduced signature of any assistant secretary of the Company, wherever appearing upon a certified copy of any power of attorney issued by the Company in connection with surety bonds, shall be valid and binding upon the Company with the same force and effect as though manually affixed.

I, Gregory W. Davenport, the undersigned, Assistant Secretary, of American Fire and Casualty Company, The Ohio Casualty Insurance Company, Liberty Mutual Insurance Company, and West American Insurance Company do hereby certify that the original power of attorney of which the foregoing is a full, true and correct copy of the Power of Attorney executed by said Companies, is in full force and effect and has not been revoked.

IN TESTIMONY WHEREOF, I have hereunto set my hand and affixed the seals of said Companies this 13th day of May, 2017.

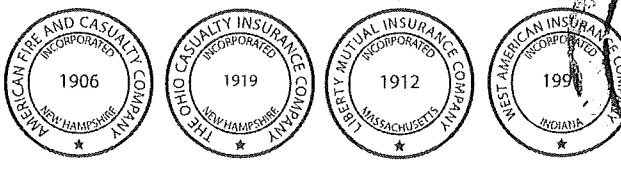

By: Gregory W. Davenport
Gregory W. Davenport, Assistant Secretary

To confirm the validity of this Power of Attorney call 1-610-832-8240 between 9:00 am and 4:30 pm EST on any business day.